

MAXIMATOR®

Maximum Pressure.

High Pressure Technology • Testing Equipment
Hydraulics • Pneumatics

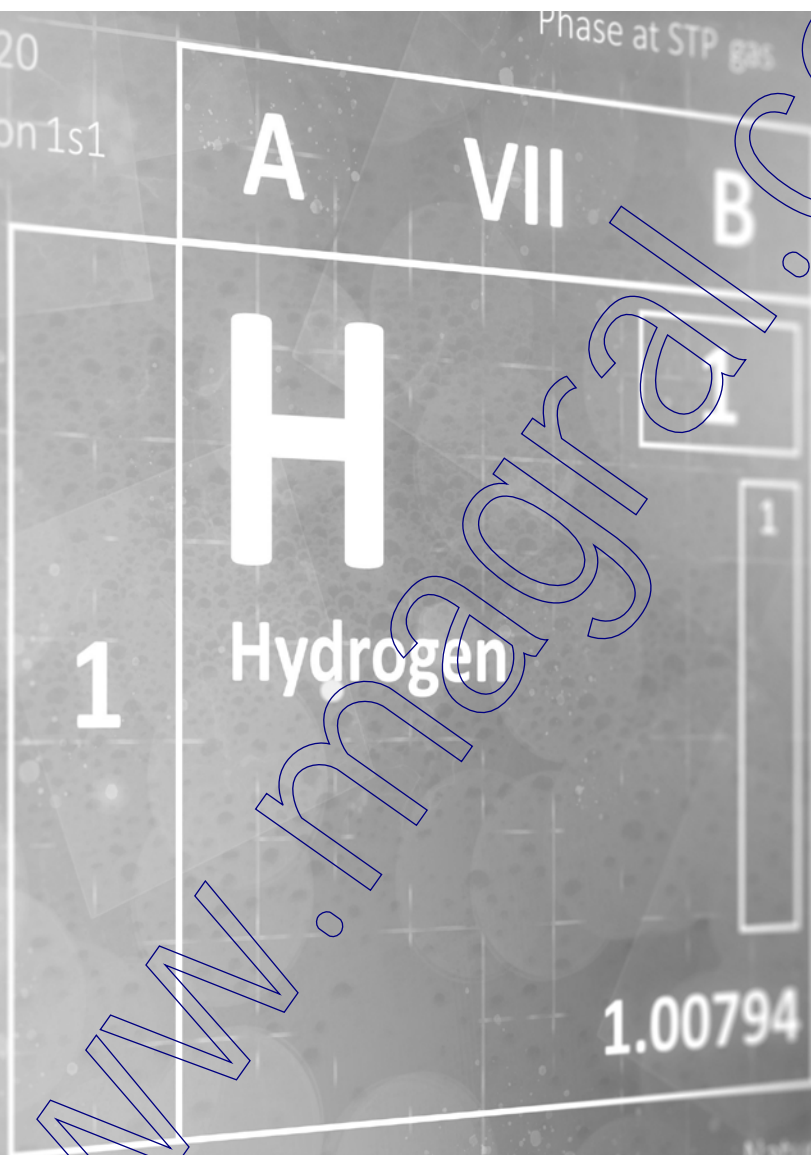

» Products for Hydrogen Applications



» Content

Content	Page
Maximator worldwide - At your side, everywhere	2
Competence in hydrogen	4
Medium Pressure Valves - Pressures to 22,500 psi (1,550 bar)	6
Double Block and Bleed Needle Valves - Pressures to 22,500 psi (1,550 bar)	8
Double Block and Bleed Needle Valves with full bore - Pressures to 22,500 psi (1,550 bar)	9
Air Actuated Valves - Pressures to 15,200 psi (1,050 bar)	
» Air Actuated Compact Valves	10
» 4-Way Air Actuated Valves for Dispenser	12
» Air Actuated Valves 1/4" - 3/8"	14
» Air Actuated Valves 9/16"	16
» Air Actuated Valves 3/4"	18
Medium Pressure Fittings - Pressures to 22,500 psi (1,550 bar)	
» Medium Pressure Fittings 1/4" - 1"	20
» Medium Pressure Fittings with variable connections 1/4" - 1"	22
Anti-vibration collet gland assemblies - Pressures to 22,500 psi (1,550 bar)	23
Check Valves - Pressures to 22,500 psi (1,550 bar)	
» Ball Check Valves & Cone Check Valves	24
Filters - Pressures to 22,500 psi (1,550 bar)	
» Line Filters	25
» Angle Filters	26
Safety Head Assembly - Pressures to 22,500 psi (1,550 bar)	27
1/4" Rupture Discs	28
Medium Pressure Tubing & Coned and threaded nipples - Pressures to 22,500 psi (1,550 bar)	29
Tools - Cone & Threading-Toobox	31
Gas Boosters	32

At your side, everywhere

As an internationally leading company specialising in high-pressure technology, Maximator develops high-performance products and solutions for a variety of uses and applications in the field of high pressure testing and production equipment, hydraulics and pneumatics.

We produce high pressure pumps, air amplifiers, gas boosters and high-pressure technology such as valves, fittings, pressure switches and other components. We also offer extensive services in the field of high-pressure testing and production technology. Our devices satisfy the requirements of the pressure equipment, machinery and ATEX directives and, on request, NACE specifications. We follow strict quality guidelines certified according to ISO 9001.

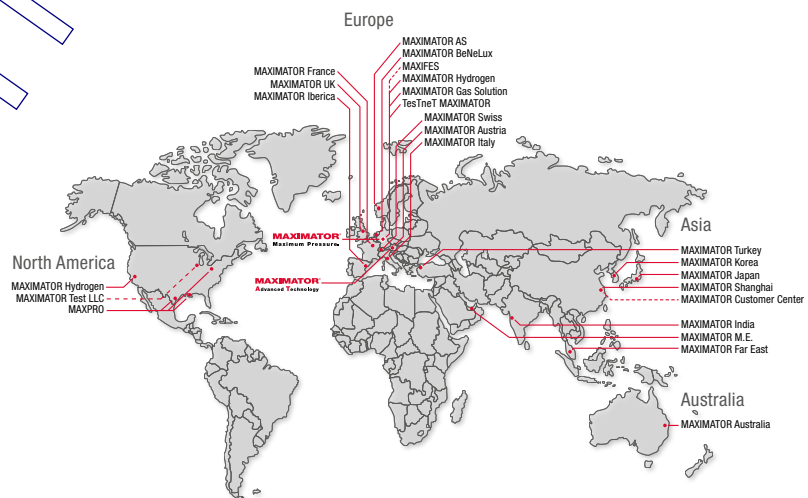

In order to ensure the continuous further development of our products, we maintain a close cooperation with our customers as well as with material and component suppliers. With four technical offices in Germany and

qualified partner companies worldwide, we can offer optimal customer service. A total of over 400 qualified, highly motivated employees work at our production centre in Nordhausen.

MAXIMATOR has been designing and manufacturing high pressure equipment for more than thirty years and has a worldwide reputation for quality and reliability, backed by one of the best service organizations in the industry.

Medium Pressure Valves to 22,500 psi (1,550 bar)

Maximator Medium Pressure Valves with metal to metal seats have a high level of safety and reliability under adverse operating conditions.

» **Sizes 1/4 to 1 inch**

Double Block and Bleed Valves to 22,500 psi (1,550 bar)

Double Block and Bleed Needle Valves are three stem manifold valves designed for blocking and bleeding in test and pressure monitoring applications as well as for chemical injection or drain line isolation up to 22,500 psi (**1,550 bar**).

Air Actuated Valves to 15,200 psi (1,050 bar)

Air Actuated Valves are a great option for process automation, pressure control or safety devices in high pressure test and production systems.

» **From slow fill processes in compact filling stations up to high flow rates for hydrogen refilling stations for busses, trucks and trains**

Medium Pressure Fittings to 22,500 psi (1,550 bar)

Maximator Medium Pressure Fittings are designed for use with the 15V series air actuated hydrogen valves and 21V series medium pressure valves and medium pressure tubing

» **Sizes 1/4 to 1 inch, also available with variable connections**

Check Valves to 22,500 psi (1,550 bar)

Especially for hydrogen applications, where best of class sealing ability is required, Maximator developed their Cone Check Valve series design with a highly media compatible soft sealing system and improved spring guide.

Filters to 22,500 psi (1,550 bar)

Cup-Type Filters are used when maximum filtration surface area down to a single micron size is required. They are used to filter gases or liquids in high pressure systems. Angle type filters allow easy in-situ replacement of the filter elements.

Tubing & Tools

Precise tools are necessary for manually coning and threading tubing. Maximator offers these tools, allowing for the coning and threading of medium and high pressure tubing up to 9/16" O.D.

Gas Boosters

The Maximator high pressure gas boosters are suitable for the oil free compression of gases and air. Industrial gases like argon, helium, nitrogen and hydrogen can be compressed to operating pressures of 2,400 bar (**36,000 psi**).

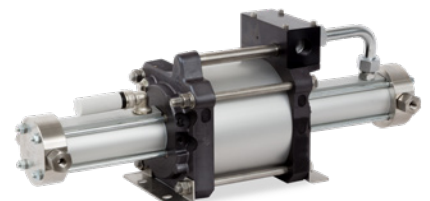
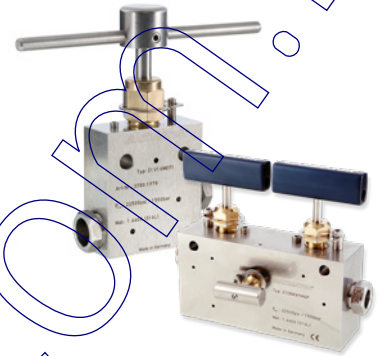

Competence in hydrogen

Maximator GmbH successfully develops complex systems in high-pressure and testing technology, hydraulics and pneumatics and has been the market leader in these segments for decades.

Maximator has many years of experience with components, power units and test systems especially for hydrogen applications. We give professional advice, plan projects and supply testing and manufacturing systems. We also develop special solutions precisely customised to the requirements of our customers.

Our high-performance service department not only carries out the installation and maintenance of the machines, we also inspect and retrofit our products, both nationally and international. In our own testing laboratories it is possible to test the product before the start of the project; we also carry out exceptional individual and series testing for your hydrogen products.

What you need to know

Hydrogen is a colourless, odourless and flavourless gas and therefore cannot be detected with our human sensory organs. Hydrogen burns with invisible flame and radiates only little heat in this process.

When mixing with air in a ratio of 4 to 76 percent by volume (vol. %) of hydrogen a detonating gas develops that already can be brought to explosion by a low-energy spark. Oxygen-hydrogen mixtures with a fraction of below 10.5 percent by volume are heavier than air and sink to the floor.

Hydrogen technology reduces CO₂ output - But is it safe?

Many components for the development of this future technology are exposed to extreme stresses. Maximator meets this challenge with innovative high pressure test technology for hydrogen components such as valves, pipes or CGH vessels.

We can carry out all legally prescribed testing on pressure bearing components with our test technology, from individual acceptance to type approval testing. We also offer gas control technology for hydrogen applications - approved effective and reliable technology for automotive manufacturers and suppliers.

Physical and chemical properties

Appearance:	colourless gas
Odour:	odourless
Molar mass:	2 g/mol
Melting point:	-259 °C
Boiling point:	-253 °C
Critical temperature:	-240 °C
Ignition temperature:	560 °C
Explosion limits (vol. % in air):	4 %(V) - 75 %(V)
Relative density, gaseous (air=1):	0,07
Solubility in water:	1,6 mg/l

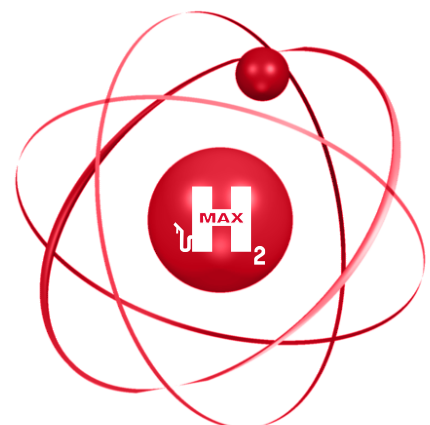
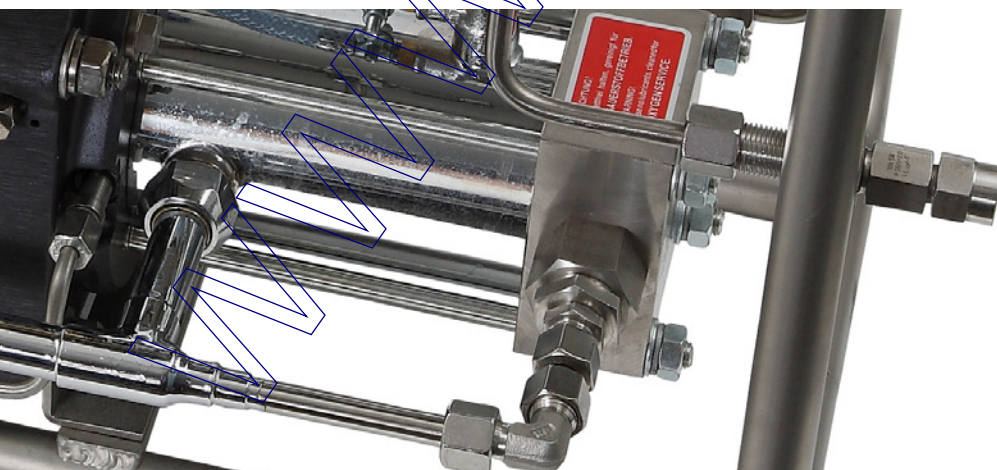

Special features of Maximator H₂ Valves

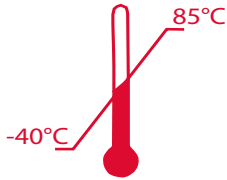

Temperature range

- Selection of seal materials for a temperature range of -40°C to +85°C
- Temperature range according to ISO19880-3 and ANSI/SAE HGV 4.7

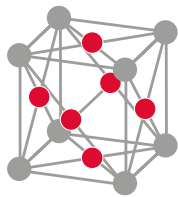

Choice of material

- Predominantly use of austenitic stainless steels, evaluated for their suitability in high pressure hydrogen applications
- Use of 1.4404 (SST 316L) as body material with minimized risk of hydrogen embrittlement for high durability
- Material 1.4980 (A286) and 1.4542 (17-4PH) for valves stems where compression stresses prevail



Leakage

- Internal leakage of seat/stem as well as external leakage over seal are bubble tight
- Leak testing of valves with helium for internal and external leakage for air operated valves
- Valves are in the qualification process in order to meet the requirements of ISO 19880-3

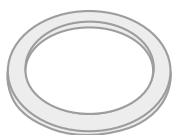

Seals

- Special seal designs are used for air operated valves instead of conventional packings in order to maintain their initial tension
- Lifetime related to opening and closing cycles is much higher compared to conventional packing designs

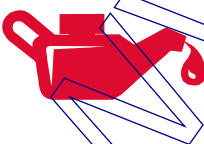

Lubrication

- Lubricant used for functionality of valves has been selected especially for hydrogen applications
- No chemical reactions with the media are going to happen

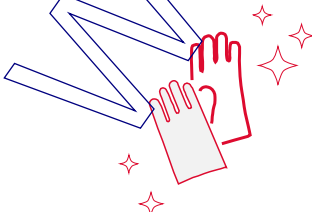

Cleaning

- Use of special cleaning process in order to reduce hydrocarbons and particles
- Avoidance of fuel cell contamination which would effect the life time

Medium Pressure Valves

» Pressures to 22,500 psi (1,550 bar)



Ordering Information
Typical catalog number:
21V16M071

Medium pressure valves

Maximator Medium pressure valves with metal to metal seats have a high level of safety and reliability under adverse operating conditions. These valves may be used both with gases and liquids.

Traceability is ensured through extensively documented data (batch number, maximum pressure, material number, type designation). All medium pressure valves include glands and collars.

» Materials:

Valve body: 1.4404 (SST 316L)

Valve stem: 1.4542 (17-4PH)

21 V Valve Series	4M O.D. Tube Size	07 Stem Type	1 Body Pattern	Options
21 V	4M – 1/4"	07 – VEE stem	1 – two-way straight	Extended
	6M – 3/8"	87 – VEE stem with replaceable seat	2 – two-way angle	temperature
	9M – 9/16"			option, see
	12M – 3/4"			information
	16M – 1"			below.

Options for Medium pressure valves

Special Designs for Extreme Temperatures

Standard valves are supplied with Teflon / Carbon packing and may be operated to 450°F (230°C). High temperature packing and / or extended stuffing box are available for service from -423°F to 1200°F (-252°C to 650°C) by adding the following suffixes to catalog order number.

- **B** – standard valve with cryogenic trim materials and Teflon packing to -100°F (-73°C).
- **LT** – extended stuffing box valve with teflon packing and cryogenic trim materials to -423°F (-252°C).

For further available options and more detailed information please refer to our VFT catalogue.

O.D. Size in. (mm)	Conne- ction Type	Orifice Size in. (mm)	Rated Cv**	Pressure Rating @ R.T. psi (bar)***
1/4 (6.35)	4MF	0.106 (2.7)	0.31	22,500 (1,550)
3/8 (9.53)	6MF	0.201 (5.1)	0.75	22,500 (1,550)
9/16 (14.29)	9MF	0.307 (7.8)	1.30	22,500 (1,550)
3/4 (19.05)	12MF	0.438 (11.1)	2.50	22,500 (1,550)
1 (25.4)	16MF	0.562 (14.3)	4.40	22,500 (1,550)

Consult your MAXIMATOR representative for **repair kits** and valve bodies. Refer to the Tools and Installation section for proper maintenance procedures.

** Cv values shown are for 2-way straight pattern vee stem valves. For 2-way angle patterns, increase the Cv value by 50%. For Flow coefficient reference curves, please refer to chapter Technical Informations.

*** See page 2 in the Technical Section of our VFT catalogue for Pressure/Temperature Rating Chart.

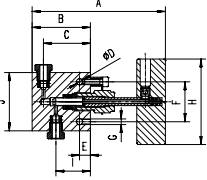
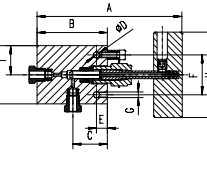
Valve Pattern	Catalog Number	Stem Type	O.D. Tube in.	Orifice in. (mm)	Dimensions in. (mm)										Valve Panel Hole	Block Thickness
					A	B	C	D	E	F	H	I	J	K		
2-Way Straight																
	21V4M071	Vee	1/4	0.106 (2.7)	4.61 (117)	2.01 (51)	1.62 (41.1)	0.22 (5.6)	0.37 (9.5)	1.24 (31.5)	2.95 (75)	1.19 (30.2)	2.01 (51)		0.75 (19.1)	0.79 (20.1)
	21V6M071	Vee	3/8	0.201 (5.1)	4.61 (117)	2.01 (51)	1.62 (41.1)	0.22 (5.6)	0.37 (9.5)	1.24 (31.5)	2.95 (75)	1.19 (30.2)	2.01 (51)		0.75 (19.1)	0.79 (20.1)
	21V9M071	Vee	9/16	0.307 (7.8)	5.87 (149)	2.88 (73.2)	2.38 (60.5)	0.37 (9.5)	0.45 (11.5)	1.38 (35)	3.94 (100)	1.75 (44.5)	2.50 (63.5)		1.00 (25.4)	1.02 (25.9)
	21V12M071	Vee	3/4	0.438 (11.1)	7.05 (179)	3.74 (95)	3.00 (76)	0.43 (11)	0.63 (16)	1.76 (44.7)	10.31 (262)	2.25 (57.2)	3.00 (76)		1.25 (31.8)	1.38 (35)
	21V16M071	Vee	1	0.562 (14.3)	8.98 (228)	4.65 (118)	3.75 (95.3)	0.53 (13.5)	1.13 (28.7)	2.50 (63.5)	10.31 (262)	2.81 (71.4)	4.13 (105)		1.62 (41.1)	1.77 (45)
2-Way Angle																
	21V4M072	Vee	1/4	0.106 (2.7)	5.00 (127)	2.43 (61.7)	1.19 (30.2)	0.22 (5.6)	0.37 (9.5)	1.24 (31.5)	2.95 (75)	1.00 (25.4)	2.01 (51)		0.75 (19.1)	0.79 (20.1)
	21V6M072	Vee	3/8	0.201 (5.1)	5.00 (127)	2.43 (61.7)	1.19 (30.2)	0.22 (5.6)	0.37 (9.5)	1.24 (31.5)	2.95 (75)	1.00 (25.4)	2.01 (51)		0.75 (19.1)	0.79 (20.1)
	21V9M072	Vee	9/16	0.307 (7.8)	6.36 (161.5)	3.38 (85.9)	1.75 (44.5)	0.37 (9.5)	0.45 (11.5)	1.38 (35)	3.94 (100)	1.25 (31.8)	2.50 (63.5)		1.00 (25.4)	1.02 (25.9)
	21V12M072	Vee	3/4	0.438 (11.1)	7.56 (192)	4.25 (108)	2.25 (57.2)	0.43 (11)	0.63 (16)	1.76 (44.7)	10.31 (262)	1.50 (38)	3.00 (76)		1.25 (31.8)	1.38 (35)
	21V16M072	Vee	1	0.562 (14.3)	9.45 (240)	5.12 (130)	2.81 (71.4)	0.53 (13.5)	1.13 (28.7)	2.50 (63.5)	10.31 (262)	2.07 (52.5)	4.13 (105)		1.62 (41.1)	1.77 (45)

G - Panel mounting screw thread size 10-24 UNC (screw included). All dimensions are for reference only and are subject to change.

Double Block and Bleed Needle Valves

» Pressures to 22,500 psi (1,550 bar)

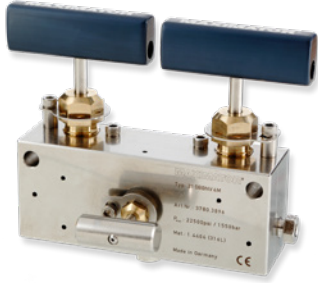

Double Block and Bleed Needle Valves

Maximator series DBBNV Double Block and Bleed Needle Valves with metal to metal seats have a high level of safety and reliability under adverse operating conditions. Double Block and Bleed Needle Valves are three stem manifold valves designed for blocking and bleeding in test and pressure monitoring applications as well as for chemical injection or drain line isolation up to 22,500 psi (1,550 bar).

Due to the standard valve packing and Vee stem design, Maximator double block and bleed needle valves are very compact and easy to use. In addition, manifold style valves reduce the number of fittings and space required for installation.

» Materials:

Valve body: 1.4404 (SST 316L)

Valve stem: 1.4542 (17-4PH)

Ordering Information
Typical catalog number:
21DBBNV4M4P

21 DBBNV Valve Series	4M Connection	4P Vent Connection
21 DBBNV	4M – 1/4"	4P – 1/4" NPT
	6M – 3/8"	6P – 3/8" NPT
	9M – 9/16"	8P – 1/2" NPT
	9H – 9/16"	4M – 1/4"

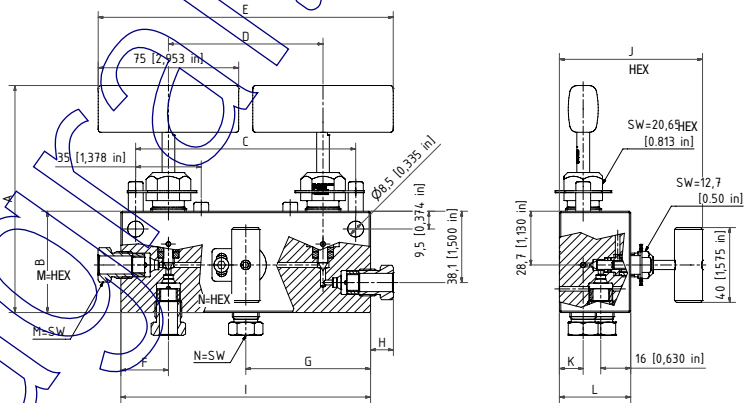

Catalog Number	Stem Type	O.D. Tube in.	Orifice in. (mm)	Dimensions in. (mm)													
				A	B	C	D	E	F	G	H	I	J	K	L	M	N
21DBBNV4M	Vee	1/4	0.11 (2.7)	4.882 (124)	2.13 (54.1)	4.63 (117.6)	3.252 (82.6)	6.205 (157.6)	1.00 (25.4)	2.626 (66.7)	0.378 (9.6)	5.252 (133.4)	3.012 (76.5)	0.50 (12.7)	1.50 (38.1)	0.50 (12.7)	0.50 (12.7)
21DBBNV4M4P	Vee	1/4	0.11 (2.7)	4.882 (124)	2.13 (54.1)	4.63 (117.6)	3.252 (82.6)	6.205 (157.6)	1.00 (25.4)	2.626 (66.7)	0.378 (9.6)	5.252 (133.4)	3.012 (76.5)	0.50 (12.7)	1.50 (38.1)	0.50 (12.7)	0.50 (12.7)
21DBBNV6M	Vee	3/8	0.11 (2.7)	4.776 (121.3)	2.13 (54.1)	4.63 (117.6)	3.252 (82.6)	6.205 (157.6)	1.00 (25.4)	2.626 (66.7)	0.48 (12.2)	5.252 (133.4)	3.012 (76.5)	0.50 (12.7)	1.50 (38.1)	0.625 (15.88)	0.625 (15.88)
21DBBNV6M6P	Vee	3/8	0.11 (2.7)	4.776 (121.3)	2.13 (54.1)	4.63 (117.6)	3.252 (82.6)	6.205 (157.6)	1.00 (25.4)	2.626 (66.7)	0.48 (12.2)	5.252 (133.4)	3.012 (76.5)	0.50 (12.7)	1.50 (38.1)	0.625 (15.88)	0.625 (15.88)
21DBBNV9M	Vee	9/16	0.11 (2.7)	5.646 (143.4)	3.00 (76.2)	4.638 (117.8)	3.26 (82.8)	6.213 (157.8)	1.311 (33.3)	2.941 (74.7)	0.63 (16)	5.882 (149.4)	3.283 (83.4)	0.752 (19.1)	1.772 (45)	0.937 (23.8)	0.937 (23.8)
21DBBNV9M8P	Vee	9/16	0.11 (2.7)	5.646 (143.4)	3.00 (76.2)	4.638 (117.8)	3.26 (82.8)	6.213 (157.8)	1.311 (33.3)	2.941 (74.7)	0.63 (16)	5.882 (149.4)	3.283 (83.4)	0.752 (19.1)	1.772 (45)	0.937 (23.8)	0.937 (23.8)
21DBBNV9H4M	Vee	9/16	0.11 (2.7)	5.646 (143.4)	3.00 (76.2)	4.638 (117.8)	3.26 (82.8)	6.213 (157.8)	1.311 (33.3)	2.941 (74.7)	0.941 (23.9)	5.882 (149.4)	3.283 (83.4)	0.752 (19.1)	1.772 (45)	1.187 (30.16)	0.50 (12.7)

Panel mounting screw thread size 10-24 UNC (screw included).

A - Stem in closed position.

All dimensions are for reference only and are subject to change.

Double Block and Bleed Needle Valves with full bore



Ordering Information
 Typical catalog number:
 21DBBV9M4P

Double Block and Bleed Needle Valves - full bore

Maximator Double Block and Bleed Needle valves with full bore will allow you to control the entire flow of your application combined with the proven benefits of an integrated solution.

21 DBBV Valve Series	9M Connection	4P Vent Connection
21 DBBV	6M - 3/8"	4P - 1/4" NPT
	9M - 9/16"	4M - 1/4"
	12M - 3/4"	
	16M - 1"	

Stem Type Vee	Catalogue Number				
	21DBBV6M	21DBBV9M	21DBBV12M	21DBBV16M	
O.D. Tube in.	3/8	9/16	3/4	1	
Orifice in. (mm)	0.201 (5.1)	0.307 (7.8)	0.438 (11.1)	0.562 (14.3)	
Dimensions in. (mm)					
	A	4.796 (121.81)	6.231 (158.27)	7.42 (188.47)	9.23 (234.5)
	B	2.362 (60)	3.346 (85)	4.134 (105)	4.921 (125)
	C	4.587 (116.5)	5.709 (145)	12.551 (318.79)	13.13 (333.5)
	D	3.346 (85)	4.331 (110)	10.787 (274)	10.63 (270)
	E	6.299 (160)	8.268 (210)	21.102 (536)	20.906 (531)
	F	1.319 (33.5)	1.319 (33.5)	1.496 (38)	2.067 (52.5)
	G	2.992 (76)	3.484 (88.5)	6.89 (175)	7.382 (187.5)
	H	0.48 (12)	0.591 (15)	0.793 (20)	0.843 (21.4)
	I	5.984 (152)	6.969 (177)	13.78 (350)	14.764 (375)
	J	3.25 (82.54)	3.25 (82.54)	3.25 (82.54)	3.762 (95.54)
	K	0.551 (14)	0.551 (14)	0.681 (17.3)	0.886 (22.5)
	L	1.752 (44.5)	1.752 (44.5)	1.752 (44.5)	2.264 (57.5)
	M	0.63 (16)	0.63 (16)	0.63 (16)	0.63 (16)
	N	1.189 (30.2)	1.752 (44.5)	2.252 (57.2)	2.693 (68.4)
	O	1.618 (41.1)	2.382 (60.5)	3 (76.2)	3.752 (95.3)
	P	0.374 (9.5)	0.374 (9.5)	0.63 (16)	1.13 (28.7)
	Q	0.335 (8.5)	0.335 (8.5)	0.433 (11)	0.531 (13.5)
	R	1.24 (31.5)	1.378 (35)	1.76 (44.7)	2.5 (63.5)
	S	2.953 (75)	3.937 (100)	10.315 (262)	10.276 (261)
	T	0.625 (15.88)	0.937 (23.8)	0.681 (30.16)	1.375 (34.93)
	U	0.625 (15.88)	0.813 (20.65)	0.937 (23.8)	1.375 (34.93)

Air Actuated Valves

» Pressures to 15,200 psi (1,050 bar)



Air Actuated Compact H₂ Valves

- Slow fill processes for compact filling stations
- Hydrogen filling of two-wheelers
- Pressure release of dispenser filling hoses

Ordering Information
 Typical catalog number:
 15V4M071-H2-3MNC

15 V Valve Series	4M O.D. Tube Size	07 Stem Type	1 Body Pattern	Configuration
15 V	4M – 1/4"	07 – VEE stem	1 – two-way straight	3MNC = Compact air-drive normally closed
15,200 psi (1,050 bar)				3MNO = Compact air-drive normally open

Technical Data and Dimensions

Technical Data

Operating temperature: -40°C / +85°C
 Drive pressure: 58 psi-116 psi (4-8 bar)
 Operating pressure: 15,200 psi (1,050 bar)

Materials

Valve body: 1.4404 (SST 316L)
 Valve stem: 1.4980
 Seal: UHMWPE

Dimensions

Height: Normally closed: 6.04 in. (154 mm)
 Normally open: 3.917 in. (99.5 mm)
 Diameter: 3.543 in. (90 mm)
 Orifice: 2.0 mm



The valves are marked with an EX sign and are in conformity to Group II Category 2G Explosion group IIC constructive safety.

15V4M071-H2-3MNC

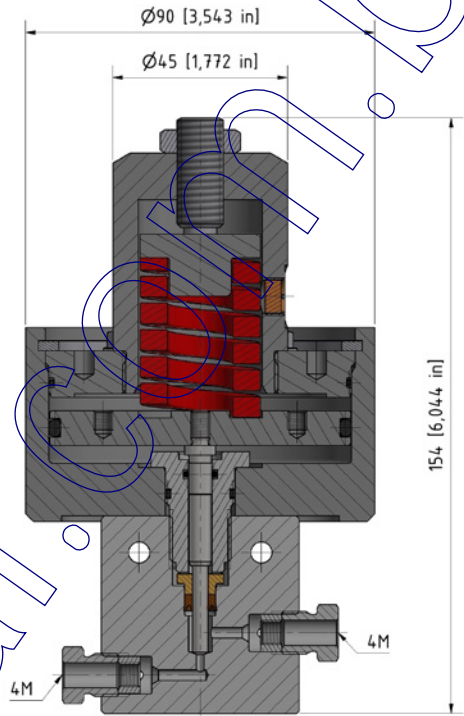
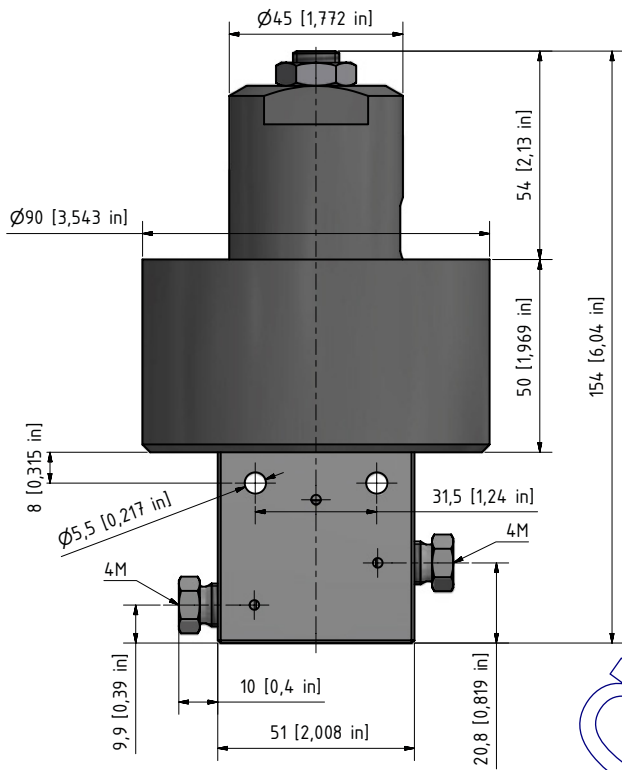

15V4M071-H2-3MNO

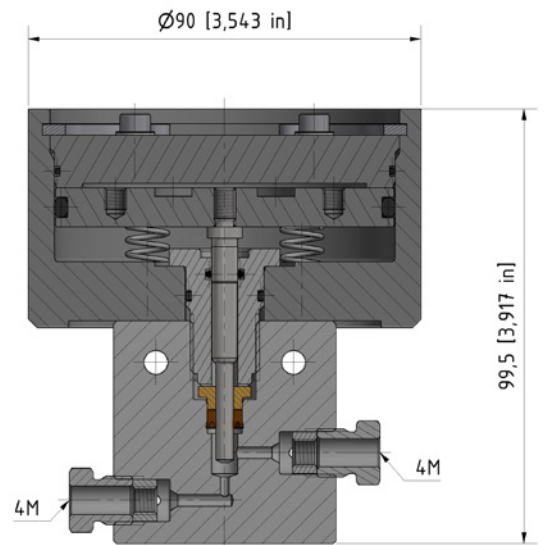
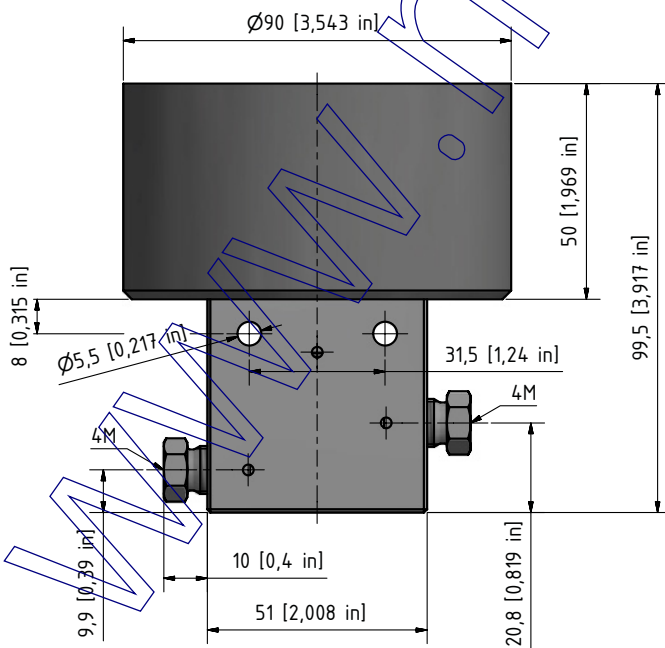

Air Actuated Valves

» Pressures to 15,200 psi (1,050 bar)

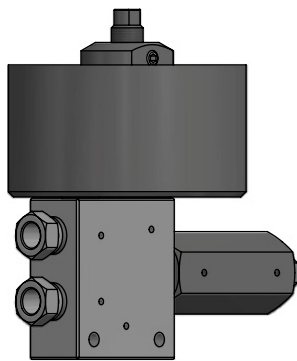

4-Way Air Actuated H₂ Valves for Dispenser includes Adjustable Stroke and Check Valve

Air Actuated H₂ Valve Manifolds

- Pressure release of dispenser filling hoses
- Adjustable orifice to limit noise emissions
- Compact design with multiple functions integrated

Ordering Information
Typical catalog number:
15V6M-H2-AS-CC4M-3MNO

15 V Valve Series	6M O.D. Tube Size	AS Stem Type	Body Pattern	Configuration
15 V	6M – 3/8"	AS – Vee Stem with adjustable stroke	4-way valve	3MNO = Compact air-drive normally open

Characteristics

- Compact integrated design for high leak integrity
- Flow through function to dispenser filling hose
- Double porting on left hand side eliminates need for Tee type fitting
- Normally open valve for pressure release after filling
- Bottom port for optional pressure relief valve or rupture disc installation
- Adjustable orifice to limit noise emissions during pressure release
- Cone check valve at outlet in order to avoid contamination from vent line
- Low wear because of optimal choice of materials of construction

Technical Data and Dimensions

Technical Data

Operating temperature: -40°C / +85°C
Drive pressure: 58 psi-116 psi (4-8 bar)
Operating pressure: 15,200 psi (1,050 bar)

Materials

Valve body: 1.4404 (SST 316L)
Valve stem: 1.4980
Seal needle valve: UHMWPE
Seal check valve: PEEK

Dimensions

Height: 5.217 in. (133 mm)
Net weight: 2.9 kg
Diameter: 3.543 in. (90 mm)
Orifice: 2.0 mm
Actuator: 3MNO



The valves are marked with an EX sign and are in conformity to Group II Category 2G Explosion group IIC constructive safety.

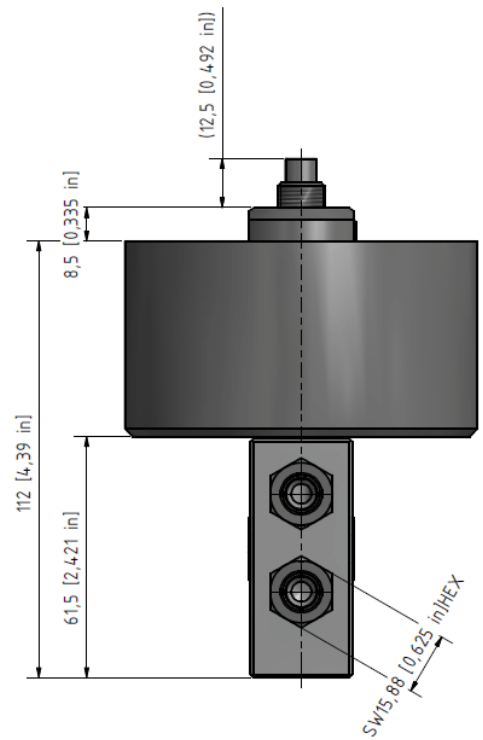
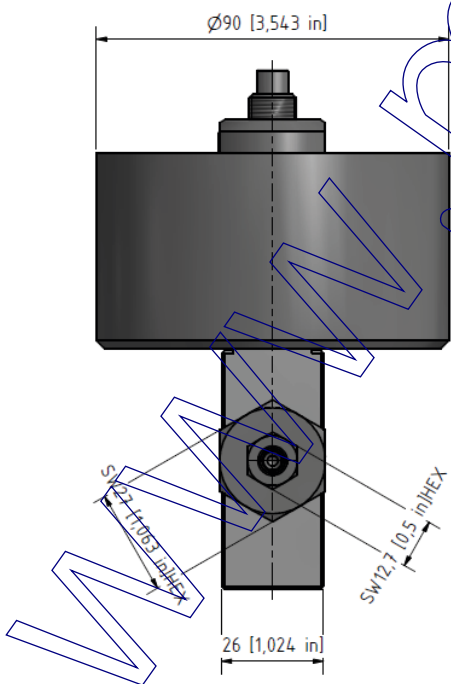
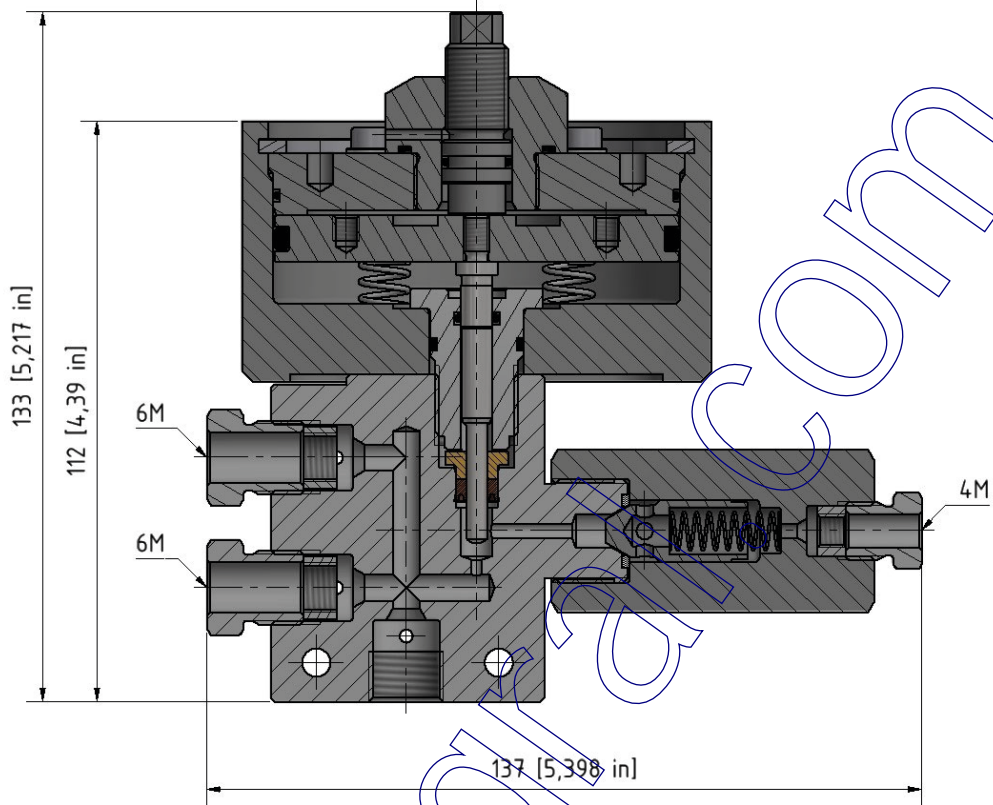

Air Actuated Valves

» Pressures to 15,200 psi (1,050 bar)



Air Actuated H₂ Valves

- Standard type for hydrogen refilling stations for passenger cars
- Use for shut-off at compressor, distribution at gas storage banks
- Shut-off function for dispenser filling hose

Ordering Information
 Typical catalog number:
 15V4M071-H2-5MNC

15 V Valve Series	4M O.D. Tube Size	07 Stem Type	1 Body Pattern	Configuration
15 V	4M – 1/4"	07 – VEE stem	1 – two-way straight	5MNC = Air-drive normally closed
	6M – 3/8"		2 – two-way angle	5MNO = Air-drive normally open
				B = Packing for cold applications (-73°)

Technical Data and Dimensions

Technical Data

Operating temperature: -40°C / +85°C (-73°C / +85°C *)
 Drive pressure: 73 psi-145 psi (5-10 bar)
 Operating pressure: 15,200 psi (1,050 bar)

Materials

Valve body: 1.4404 (SST 316L)
 Valve stem: 1.4980
 Seal: UHMWPE

Dimensions

Height: 195 mm (245 mm *)
 Net weight: 5.6 kg
 Diameter: 155 mm
 Orifice: 4M: 2.7 mm
 6M: 5.1 mm

* B-Type with extended connection for low temperature applications



The valves are marked with an EX sign and are in conformity to Group II Category 2G Explosion group IIC constructive safety.

15V4M071-H2-5MNO

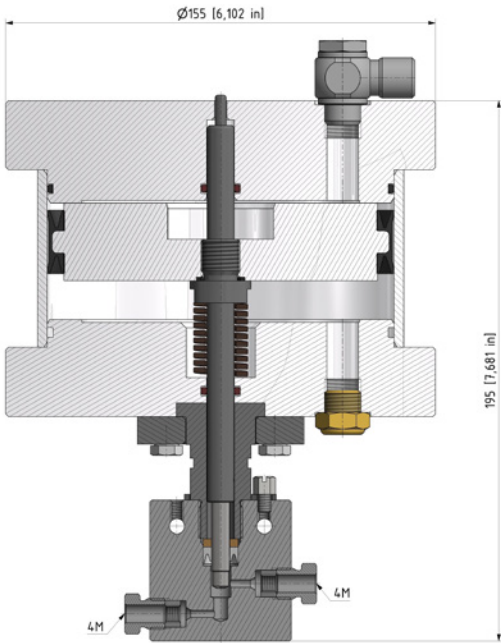

15V4M071-B-H2-5MNO

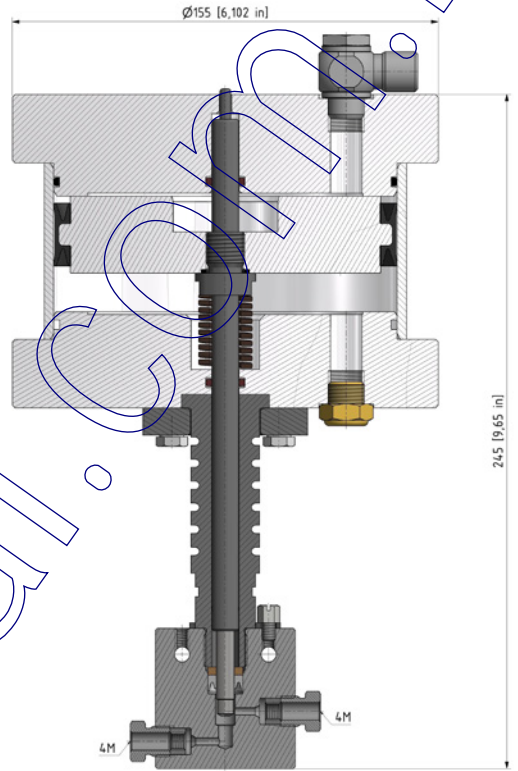

15V6M071-H2-5MNC

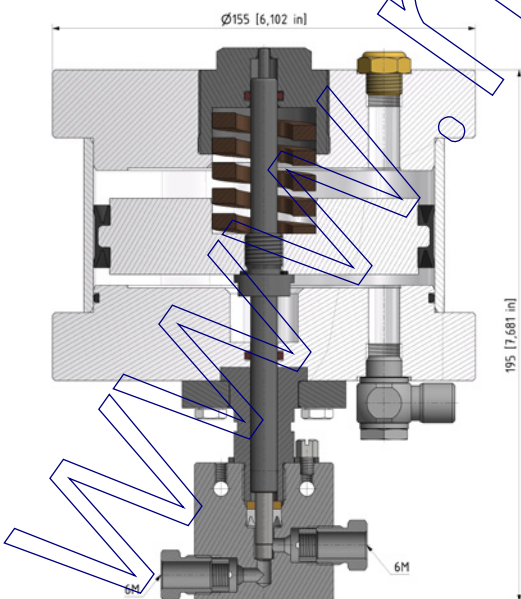

15V6M071-B-H2-5MNC

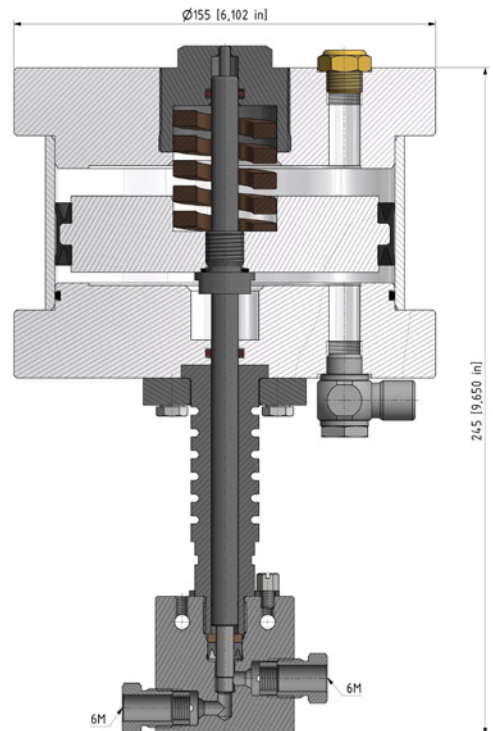

Air Actuated Valves

» Pressures to 15,200 psi (1,050 bar)



Air Actuated H₂ Valves

Air Actuated High Flow Valves

- Standard type for hydrogen refilling stations for busses, trucks and trains
- Use for shut-off at compressor, distribution at gas storage banks
- Shut-off function for dispenser filling hose

Ordering Information
Typical catalog number:
15V9M071-H2-8MNC

15 V Valve Series	9M O.D. Tube Size	07 Stem Type	1 Body Pattern	Configuration
15 V	9M – 9/16"	07 – VEE stem	1 – two-way straight	8MNC = Air-drive normally closed
			2 – two-way angle	

Technical Data and Dimensions

Technical Data

Operating temperature: -40°C / +85°C
Drive pressure: 73 psi-145 psi (5-10 bar)
Operating pressure: 15,200 psi (1,050 bar)

Materials

Valve body: 1.4404 (SST 316L)
Valve stem: 1.4980
Seal: UHMWPE

Dimensions

Height: 291 mm
Net weight: 16.8 kg
Width: 220 mm x 220 mm
Orifice: 7.8 mm
Actuator: 8MNC



The valves are marked with an EX sign and are in conformity to Group II Category 2G Explosion group IIC constructive safety.

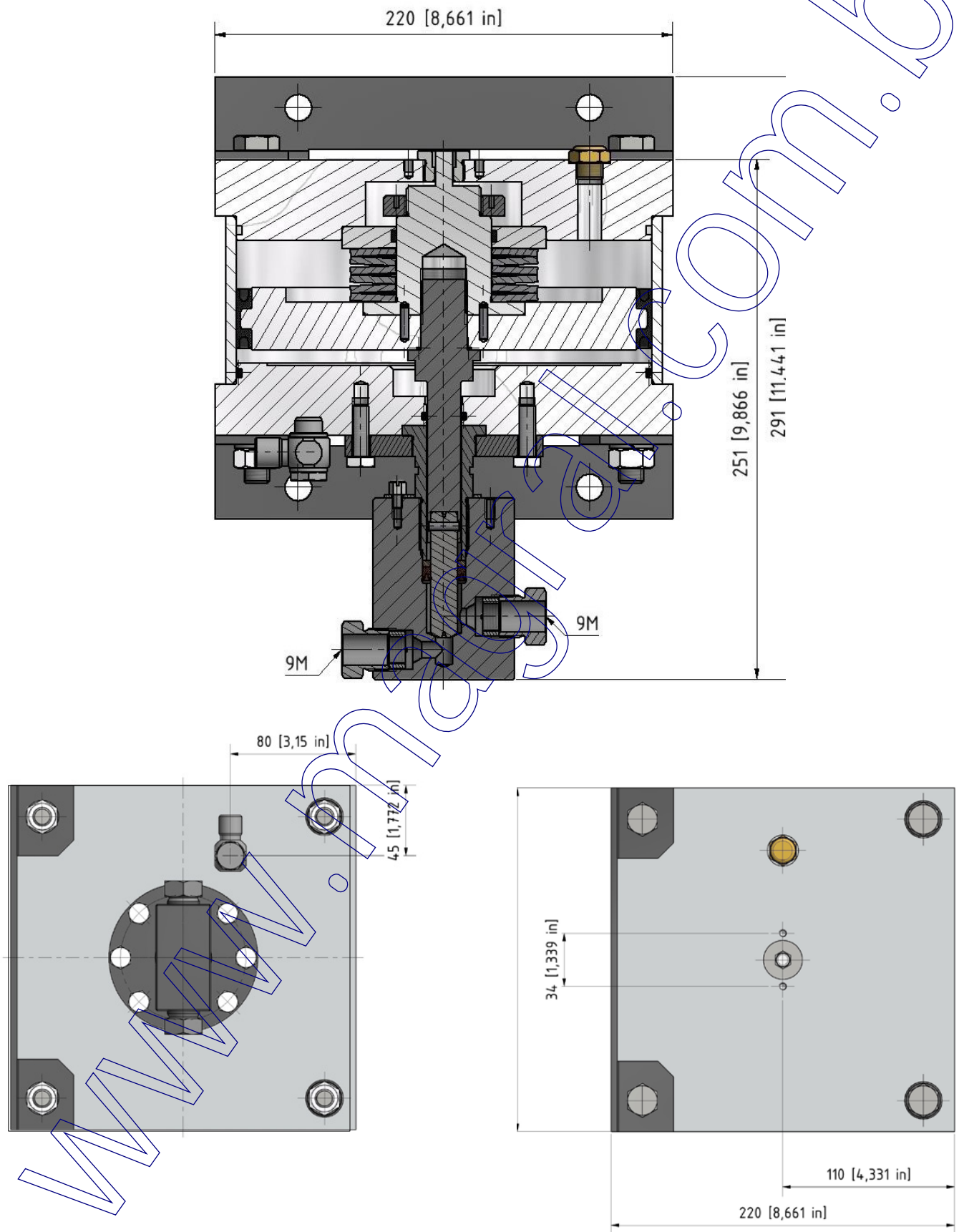

Air Actuated Valves

» Pressures to 15,200 psi (1,050 bar)



Ordering Information
 Typical catalog number:
 15V12M071-H2-8MNC

Air Actuated H₂ Valves

Air Actuated High Flow Valves

- Standard type for hydrogen refilling stations for busses, trucks and trains
- Use for shut-off at compressor, distribution at gas storage banks
- Shut-off function for dispenser filling hose

15 V Valve Series	12M O.D. Tube Size	07 Stem Type	1 Body Pattern	Configuration
15 V	12M – 3/4"	07 – VEE stem	1 – two-way straight	8MNC = Air-drive normally closed
			2 – two-way angle	

Technical Data and Dimensions

Technical Data

Operating temperature: -40°C / +85°C
 Drive pressure: 102 psi-145 psi (7-10 bar)
 Operating pressure: 15,200 psi (1,050 bar)

Materials

Valve body: 1.4404 (SST 316L)
 Valve stem: 1.4980
 Seal: UHMWPE

Dimensions

Height: 357 mm
 Net weight: 24.4 kg
 Width: 220 mm x 220 mm
 Orifice: 11.1 mm
 Actuator: 8MNC



The valves are marked with an EX sign and are in conformity to Group II Category 2G Explosion group IIC constructive safety.

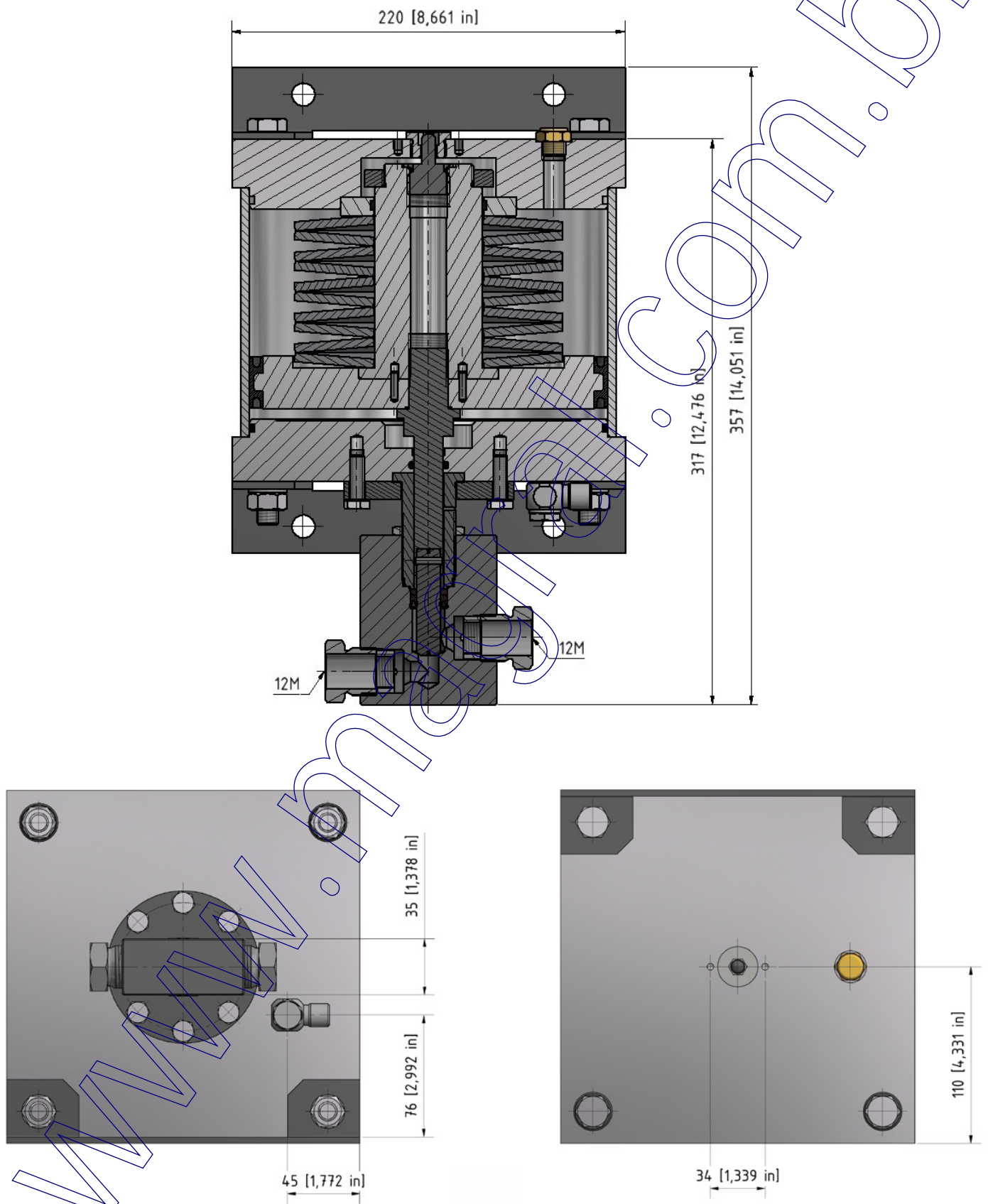

Medium Pressure Fittings

» Pressures to 22,500 psi (1,550 bar)

Medium pressure fittings

Maximator medium pressure fittings are designed for use with the 15V series hydrogen valves and 21V series medium pressure valves and medium pressure tubing. All medium pressure fittings have coned and threaded type connections. Mounting holes are standard on all elbows, tees and crosses.



Tubing Size in. (mm)	Gland	Collar	Plug	Tubing Cap
	1/4 (6.35)	21G4M	21C4M	21P4M
3/8 (9.53)	21G6M	21C6M	21P6M	21TC6M
9/16 (14.29)	21G9M	21C9M	21P9M	21TC9M
3/4 (19.05)	21G12M	21C12M	21P12M	21TC12M
1 (25.4)	21G16M	21C16M	21P16M	21TC16M

Connection Components

All medium pressure fittings are supplied with glands and collars. Refer to the adjacent chart for ordering any of the connection components individually. When using the plug, the collar is not needed.

» Materials:

Fitting body: 1.4404 (SST 316L)

Gland, collar: 1.4404 (SST 316L)

Fitting Pattern	Catalog Number	Connection Type	O.D. Tube Size in.	Orifice in. (mm)	Dimensions in. (mm)							Block Thickness
					A	B	C	D	E	F	G	
Elbow												
	21L4M	4MF	1/4	0.106 (2.7)	0.75 (19.1)	1.10 (28)	1.54 (39.1)	0.75 (19.1)	0.49 (12.5)	0.49 (12.5)	0.22 (5.6)	0.63 (16)
	21L6M	6MF	3/8	0.201 (5.1)	1.00 (25.4)	1.38 (35)	2.00 (50.8)	1.00 (25.4)	0.63 (16)	0.63 (16)	0.26 (6.6)	0.79 (20.1)
	21L9M	9MF	9/16	0.307 (7.8)	1.25 (31.8)	1.75 (44.5)	2.50 (63.5)	1.25 (31.8)	0.84 (21.3)	0.84 (21.3)	0.33 (8.4)	1.02 (25.9)
	21L12M	12MF	3/4	0.438 (11.1)	1.50 (38.1)	2.25 (57.2)	3.00 (76)	1.50 (38.1)	1.00 (25.4)	1.00 (25.4)	0.35 (8.9)	1.38 (35)
	21L16M	16MF	1	0.562 (14.3)	2.06 (52.3)	3.00 (76)	4.13 (105)	2.06 (52.3)	1.38 (35)	1.38 (35)	0.53 (13.5)	1.77 (45)
Tee												
	21T4M	4MF	1/4	0.106 (2.7)	0.75 (19.1)	1.10 (28)	1.54 (39.1)	0.75 (19.1)	0.49 (12.5)	0.98 (25)	0.22 (5.6)	0.63 (16)
	21T6M	6MF	3/8	0.201 (5.1)	1.00 (25.4)	1.38 (35)	2.00 (50.8)	1.00 (25.4)	0.63 (16)	1.26 (32)	0.26 (6.6)	0.79 (20.1)
	21T9M	9MF	9/16	0.307 (7.8)	1.25 (31.8)	1.75 (44.5)	2.50 (63.5)	1.25 (31.8)	0.84 (21.3)	1.67 (42.6)	0.33 (8.4)	1.02 (25.9)
	21T12M	12MF	3/4	0.438 (11.1)	1.50 (38.1)	2.25 (57.2)	3.00 (76)	1.50 (38.1)	1.00 (25.4)	2.00 (50.8)	0.35 (8.9)	1.38 (35)
	21T16M	16MF	1	0.562 (14.3)	2.06 (52.3)	3.00 (76)	4.13 (105)	2.06 (52.3)	1.38 (35)	2.76 (70)	0.53 (13.5)	1.77 (45)

All dimensions are for reference only and are subject to change.

Medium Pressure Fittings

» Pressures to 22,500 psi (1,550 bar)

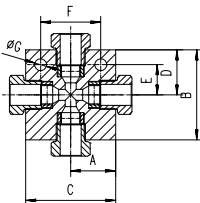
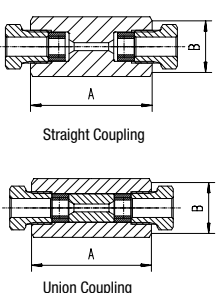
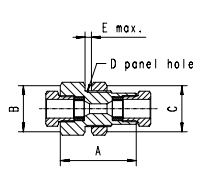
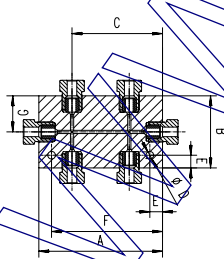
Fitting Pattern	Catalog Number	Connection Type	O.D. Tube Size in.	Orifice in. (mm)	Dimensions in. (mm)							Block Thickness
					A	B	C	D	E	F	G	
Cross												
	21X4M	4MF	1/4	0.106 (2.7)	0.77 (19.5)	1.54 (39.1)	1.54 (39.1)	0.77 (19.5)	0.49 (12.5)	0.98 (25)	0.22 (5.6)	0.63 (16)
	21X6M	6MF	3/8	0.201 (5.1)	1.00 (25.4)	2.00 (50.8)	2.00 (50.8)	1.00 (25.4)	0.63 (16)	1.26 (32)	0.26 (6.6)	0.79 (20.1)
	21X9M	9MF	9/16	0.307 (7.8)	1.25 (31.8)	2.50 (63.5)	2.50 (63.5)	1.25 (31.8)	0.84 (21.3)	1.67 (42.6)	0.33 (8.4)	1.02 (25.9)
	21X12M	12MF	3/4	0.438 (11.1)	1.50 (38.1)	3.00 (76)	3.00 (76)	1.50 (38.1)	1.00 (25.4)	2.00 (50.8)	0.35 (8.9)	1.38 (35)
	21X16M	16MF	1	0.562 (14.3)	2.06 (52.3)	4.13 (105)	4.13 (105)	2.06 (52.3)	1.38 (35)	2.76 (70)	0.53 (13.5)	1.77 (45)
Straight Coupling / Union Coupling												
	21F4M	4MF	1/4	0.106 (2.7)	1.62 (41.1)	0.69 (17.5)	Straight Coupling					
	21UF4M						Union Coupling					
	21F6M	6MF	3/8	0.201 (5.1)	1.75 (44.5)	0.88 (22.3)	Straight Coupling					
	21UF6M						Union Coupling					
	21F9M	9MF	9/16	0.307 (7.8)	2.12 (53.8)	1.06 (27)	Straight Coupling					
	21UF9M						Union Coupling					
	21F12M	12MF	3/4	0.438 (11.1)	2.50 (63.5)	1.44 (36.5)	Straight Coupling					
	21UF12M						Union Coupling					
21F16M	16MF	1	0.562 (14.3)	3.50 (88.9)	2.00 (50.8)	Straight Coupling						
21UF16M						Union Coupling						
Bulkhead Coupling												
	21BF4M	4MF	1/4	0.106 (2.7)	1.88 (47.8)	1.06 (27)	1.06 (27)	0.94 (23.9)	0.67 (17)			
	21BF6M	6MF	3/8	0.201 (5.1)	2.01 (51)	1.06 (27)	1.06 (27)	0.94 (23.9)	0.39 (9.9)			
	21BF9M	9MF	9/16	0.307 (7.8)	2.38 (60.5)	1.44 (36.5)	1.44 (36.5)	1.12 (28.5)	0.39 (9.9)			
	21BF12M	12MF	3/4	0.438 (11.1)	2.81 (71.4)	1.62 (41.3)	1.62 (41.3)	1.37 (34.8)	0.47 (11.9)			
	21BF16M	16MF	1	0.562 (14.3)	3.54 (89.9)	2.00 (50.8)	2.00 (50.8)	1.68 (42.6)	0.51 (13)			
Manifold Block												
	21MB64M	4MF	1/4	0.106 (2.7)	3.39 (86)	1.54 (39.1)	2.6 (66)	0.22 (5.5)	0.28 (7)	3.11 (79)	0.77 (19.5)	0.63 (16)
	21MB66M	6MF	3/8	0.201 (5.1)	3.39 (86)	2.00 (50.8)	2.38 (60.5)	0.26 (6.5)	0.37 (9.5)	3.01 (76.5)	1.00 (25.5)	0.79 (20.1)
	21MB69M	9MF	9/16	0.307 (7.8)	5.12 (130)	2.50 (63.5)	3.86 (98)	0.33 (8.5)	0.41 (10.5)	4.7 (119.5)	1.25 (31.75)	1.02 (25.9)
	21MB612M	12MF	3/4	0.438 (11.1)	6.50 (165)	3.00 (76)	5.00 (127)	0.35 (9)	0.49 (12.5)	6.00 (152.5)	1.5 (38)	1.38 (35)
	21MB616M	16MF	1	0.562 (14.3)	7.25 (191)	4.13 (105)	5.45 (138.5)	0.53 (13.5)	0.69 (17.5)	6.83 (173.5)	2.07 (52.5)	1.77 (45)

All dimensions are for reference only and are subject to change.

All technical and dimensional information subject to change. All general Terms and Conditions of sale, including limitations of our liability, apply to all products and services sold.

Medium Pressure Fittings - variable connections

» Pressures to 22,500 psi (1,550 bar)

Medium pressure fittings with variable connections

Maximator also offers medium pressure elbow, tee and cross fittings with variable connections. The dimensions depend on the largest connection type. All medium pressure fittings have coned and threaded type connections. Mounting holes are standard on all elbows, tees and crosses.

Elbow

Body structure

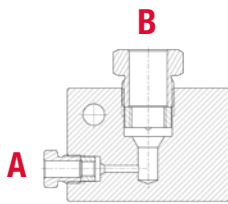

Catalog Number **21L A B**

Example:

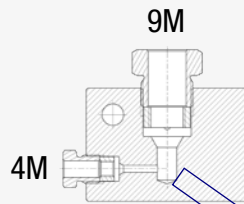

Catalog Number
21L 4M 9M

Largest connection type*

Tee

Body structure

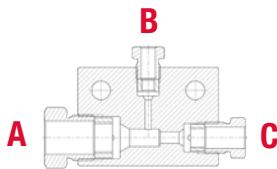

Catalog Number **21T A B C**

Example:

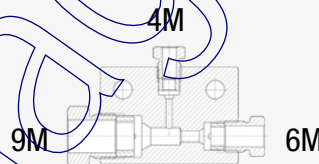

Catalog Number
21T 9M 4M 6M

Largest connection type*

Cross

Body structure

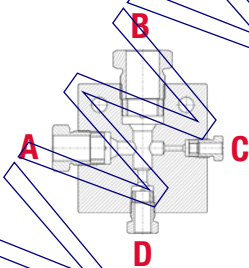

Catalog Number **21X A B C D**

Example:

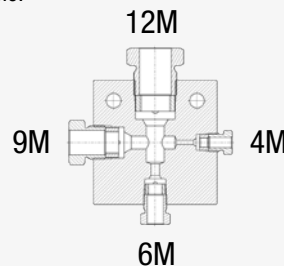

Catalog Number
21X 9M 12M 4M 6M

Largest connection type*

* All dimensions can be found on the previous pages.

All dimensions are for reference only and are subject to change.

All technical and dimensional information subject to change. All general Terms and Conditions of sale, including limitations of our liability, apply to all products and services sold.

Anti-Vibration Collet Gland Assembly

» Pressures to 22,500 psi (1,550 bar)

Anti-vibration collet gland assemblies

Maximator anti-vibration collet gland assemblies are for use in applications where there could be extreme external mechanical vibrations or shock in tubing lines. These collet gland assemblies are interchangeable with the standard medium pressure coned and threaded tube connections.

In a normal coned and threaded tube connection, any external mechanical loading on the tubing lines, valves or fittings would be concentrated on the first thread of the tube. This can cause failure of the tube at this thinner cross-section. The anti-vibration collet gland assembly grips the tube behind the connection, supporting the tube at the full cross-section and straight area, moving the loading away from the threaded area.

The back part of the assembly has a gland nut that, when tightened properly, compresses a split collet on the tube, providing the beneficial gripping action. All anti-vibration collet gland assemblies come with a Molybdenum Disulfide Coating to guard against galling of the stainless components.



Gland Pattern	Catalog Number	Part	O.D. Tubing Size in.	Dimensions in. (mm)		
				A	B (Hex.)	C (Hex.)
	21AVA4M	Complete Assembly	1/4	1.27	0.50	0.62
	21AVB4M	Collet Body		(32.2)	(12,7)	(15,7)
	21AVC4M	Slotted Collet				
	21AVG4M	Gland Nut				
	21AVA6M	Complete Assembly	3/8	1.54	0.62	0.81
	21AVB6M	Collet Body		(39.1)	(15,7)	(20,6)
	21AVC6M	Slotted Collet				
	21AVG6M	Gland Nut				
	21AVA9M	Complete Assembly	9/16	1.82	0.94	0.94
	21AVB9M	Collet Body		(46.2)	(23,9)	(23,9)
	21AVC9M	Slotted Collet				
	21AVG9M	Gland Nut				
21AVA12M	Complete Assembly	3/4	2.01	1.19	1.25	
21AVB12M	Collet Body		(51)	(30,2)	(31,8)	
21AVC12M	Slotted Collet					
21AVG12M	Gland Nut					
21AVA16M	Complete Assembly	1	2.44	1.38	1.50	
21AVB16M	Collet Body		(62)	(35)	(38,1)	
21AVC16M	Slotted Collet					
21AVG16M	Gland Nut					

All dimensions are for reference only and are subject to change.

Check Valves

» Pressures to 22,500 psi (1,550 bar)

Ball Check Valves

Ball Check Valves prevent reverse flow where bubble tight shut-off is not mandatory. These check valves are designed with a ball cradled floating poppet to assure positive inline seating. This poppet design allows full flow around the ball to minimize pressure drop. Check valves are rated to 660°F (350°C). All check valves are supplied with glands and collars. These check valves are not to be used as a relief device. The opening pressure of the Ball Check Valves is approx. 20 psi (1.5 bar).



» **Materials:** Body, cover, poppet, cover gland: 1.4404 (SST 316L)
Ball: SST 400-series Spring: SST 300 series

Valve Pattern	Catalog Number	Connection Type	Pressure Rating psi (bar)	Orifice in. (mm)	Rated (Cv)	Dimensions in. (mm)	
						A (Hex.)	B
Ball Check Valves							
	21BC4M	4MF	22,500 (1,550)	0.106 (2.7)	0.28	0.88 (22.3)	2.91 (73.9)
	21BC6M	6MF	22,500 (1,550)	0.201 (5.1)	0.84	1.06 (27)	3.31 (84.1)
	21BC9M	9MF	22,500 (1,550)	0.307 (7.8)	2.30	1.44 (36.5)	4.29 (109)
	21BC12M	12MF	22,500 (1,550)	0.438 (11.1)	4.70	2.00 (50.8)	5.46 (138.7)
	21BC16M	16MF	22,500 (1,550)	0.562 (14.3)	7.40	2.00 (50.8)	6.57 (166.9)



Cone Check Valves

Especially for hydrogen applications, where best of class sealing ability is required, Maximator developed their cone check valve series design with a highly media compatible soft sealing system and improved spring guide. This series is available for Medium Pressure applications up to 22,500 psi (1,550 bar) with 4M to 16M connection.

» **Materials:** Body, sealing cone: 1.4404 (SST 316L) Seal: PEEK

Valve Pattern	Catalog Number	Connection Type	Pressure Rating psi (bar)	Orifice in. (mm)	Rated (Cv)	Dimensions in. (mm)	
						A (Hex.)	B
Cone Check Valves							
	21CC4M-H2	4MF	22,500 (1,550)	0.106 (2.7)	0.28	0.88 (22.3)	2.91 (73.9)
	21CC6M-H2	6MF	22,500 (1,550)	0.201 (5.1)	0.84	1.06 (27)	3.31 (84.1)
	21CC9M-H2	9MF	22,500 (1,550)	0.307 (7.8)	2.30	1.44 (36.5)	4.29 (109)
	21CC12M-H2	12MF	22,500 (1,550)	0.438 (11.1)	4.70	2.00 (50.8)	5.35 (136)
	21CC16M-H2	16MF	22,500 (1,550)	0.562 (14.3)	7.40	2.00 (50.8)	6.88 (175)

All dimensions are for reference only and are subject to change.

Line Filters

» Pressures to 22,500 psi (1,550 bar)

Cup-Type Line Filters

Maximator Cup-Type Line Filters are used when maximum filtration surface area and a single micron size element is preferred. This design increases the filter area as much as 6 times the area of the disc type filter, and will permit higher flow rates with a lower pressure drop, and longer intervals between element changes.

Filter elements come standard in 5, 30, or 56 micron sizes and are easily replaced. Filters are rated for temperatures -423°F to 660°F (-252°C to 350°C). All line filters come with glands and collars.

» Materials:

Body, cover, cover gland: 1.4404 (SST 316L)

Element: 1.4404 (SST 316L)

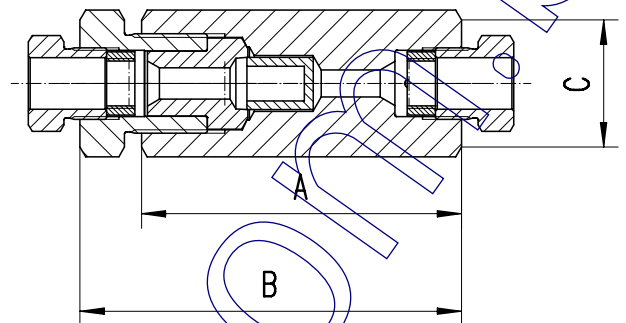

Catalog Number	Pressure Rating psi (bar)	Orifice in. (mm)	Micron Size	Connection Type	Filter Element Area in. ² (mm) ²	Dimensions in. (mm)		
						A	B	C (Hex.)
Cup-Type Line Filters								
21CF4M-5	22,500 (1,550)	0.106 (2.7)	5	4MF	0.82 (530)	2.38 (60.5)	2.87 (72.9)	0.88 (22.3)
21CF4M-30			30					
21CF4M-56			56					
21CF6M-5	22,500 (1,550)	0.201 (5.1)	5	6MF	0.82 (530)	2.83 (71.8)	3.35 (85.1)	1.06 (27)
21CF6M-30			30					
21CF6M-56			56					
21CF9M-5	22,500 (1,550)	0.307 (7.8)	5	9MF	1.55 (1,000)	3.63 (92.2)	4.33 (110)	1.44 (36.5)
21CF9M-30			30					
21CF9M-56			56					
21CF12M-5	22,500 (1,550)	0.438 (11.1)	5	12MF	6.14 (3,960)	5.75 (146)	6.57 (166.9)	2.00 (50.8)
21CF12M-30			30					
21CF12M-56			56					
21CF16M-5	22,500 (1,550)	0.582 (14.3)	5	16MF	6.14 (3,960)	5.75 (146)	6.57 (166.9)	2.00 (50.8)
21CF16M-30			30					
21CF16M-56			56					

It is recommended that all fluids entering a high pressure system be thoroughly cleaned.

Maximator filters are designed to remove small amounts of process particles. Pressure differential should not exceed 1000 psi across the filter elements.

All dimensions for reference only and are subject to change.

All technical and dimensional information subject to change. All general Terms and Conditions of sale, including limitations of our liability, apply to all products and services sold.

Angle Filters

» Pressures to 22,500 psi (1,550 bar)

Angle Filters

Maximator Angle Filters are used to filter gases or liquids in high pressure systems. The filter elements can be easily changed in-situ. The special design allows the exchange of the filter element without the need to first disassemble the filter in front of the tubing. Filter elements are made of sintered material with pore sizes of 5 µm, 30 µm or 56 µm. Filters are rated for temperatures -423°F to 660°F (-252°C to 350°C). All angle filters come with glands and collars.

» Materials:

Body, cover, cover gland: 1.4404 (SST 316L)

Element: 1.4404 (SST 316L)

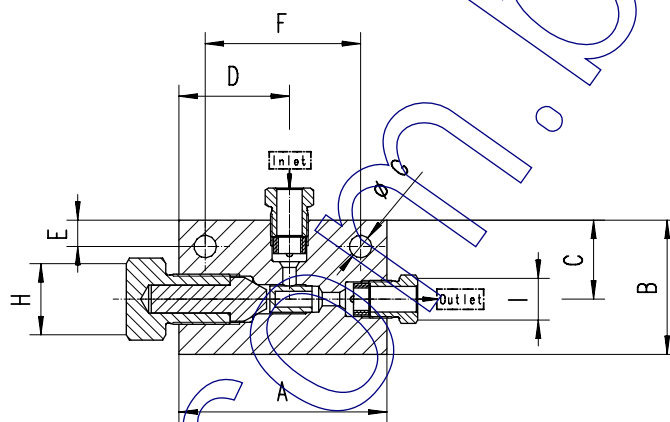

Catalog Number	Pressure Rating psi (bar)	Orifice in. (mm)	Connection Type	Micron Size	Filter Ele- ment Areas in. ² (mm ²)	Dimensions in. (mm)									Block thick- ness
						A	B	C	D	E	F	G	H (Hex.)	I (Hex.)	
Angle Filter															
21AF4M-5	22,500 (1,550)	0.106 (2.7)	4M	5	0.82 (530)	3.11 (79)	2.01 (51)	1.18 (30)	1.65 (42)	0.39 (10)	2.32 (59)	0.34 (8.5)	1.06 (27)	0.50 (12.7)	1.02 (26)
21AF4M-30				30											
21AF4M-56				56											
21AF6M-5	22,500 (1,550)	0.201 (5.1)	6M	5	0.82 (530)	3.11 (79)	2.01 (51)	1.18 (30)	1.65 (42)	0.39 (10)	2.32 (59)	0.34 (8.5)	1.06 (27)	0.50 (12.7)	1.02 (26)
21AF6M-30				30											
21AF6M-56				56											
21AF9M-5	22,500 (1,550)	0.307 (7.8)	9M	5	1.55 (1,000)	3.62 (92)	2.64 (67)	1.61 (41)	1.81 (46)	0.51 (13)	2.17 (55)	0.34 (8.5)	1.19 (30.2)	0.94 (23.8)	1.54 (39)
21AF9M-30				30											
21AF9M-56				56											
21AF12M-5	22,500 (1,550)	0.438 (11.1)	12M	5	6.14 (3,960)	5.71 (145)	3.54 (90)	2.3 (57.2)	2.44 (62)	0.39 (10)	4.92 (125)	0.34 (8.5)	2.00 (50.8)	1.19 (30.2)	2.25 (57.15)
21AF12M-30				30											
21AF12M-56				56											
21AF16M-5	22,500 (1,550)	0.562 (14.3)	16M	5	6.14 (3,960)	5.71 (145)	3.54 (90)	2.3 (57.2)	2.44 (62)	0.39 (10)	4.92 (125)	0.34 (8.5)	2.00 (50.8)	1.38 (34.9)	2.25 (57.15)
21AF16M-30				30											
21AF16M-56				56											

It is recommended that all fluids entering a high pressure system be thoroughly cleaned.

Maximator filters are designed to remove small amounts of process particles. Pressure differential should not exceed 1000 psi across the filter elements.

All dimensions for reference only and are subject to change.

All technical and dimensional information subject to change. All general Terms and Conditions of sale, including limitations of our liability, apply to all products and services sold.

Safety Head Assembly

» Pressures to 22,500 psi (1,550 bar)

Safety head assemblies

Maximator safety head assemblies are used to provide over-pressure protection to high pressure systems. These safety head assemblies are to be used with the appropriate 1/4" angular rupture disc listed on the next page.

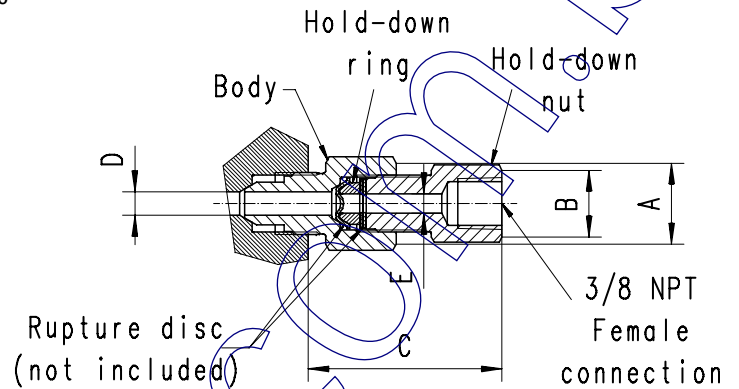

Safety Head Assembly Catalog Number without Disc	Fits Connection Type	Pressure Rating psi (bar)	Body Torque ft - lbs. (Nm)	Dimensions in. (mm)				
				A (Hex.)	B (Hex.)	C (L.G.)	D (I.D.)	E (I.D.)
21SH4M	4MF	22,500 (1,550)	20 (30)	1.06 (27)	0.88 (22.3)	2.48 (63)	0.109 (2.8)	0.250 (6.3)
21SH6M	6MF	22,500 (1,550)	30 (40)	1.06 (27)	0.88 (22.3)	2.72 (69.1)	0.203 (5.1)	0.250 (6.3)
21SH9M	9MF	22,500 (1,550)	55 (75)	1.06 (27)	0.88 (22.3)	2.51 (63.7)	0.255 (6.5)	0.250 (6.3)
21SH12M	12MF	22,500 (1,550)	90 (120)	1.19 (30.2)	0.88 (22.3)	2.72 (69.1)	0.307 (7.8)	0.250 (6.3)
21SH16M	16MF	22,500 (1,550)	150 (200)	1.44 (36.6)	0.88 (22.3)	2.72 (69.1)	0.307 (7.8)	0.250 (6.3)

All dimensions for reference only and are subject of change

Rupture disc flat design up to 8,700 psi (600 bar)

Rupture disc hat-shaped design ≥ 8,700 psi (600 bar)

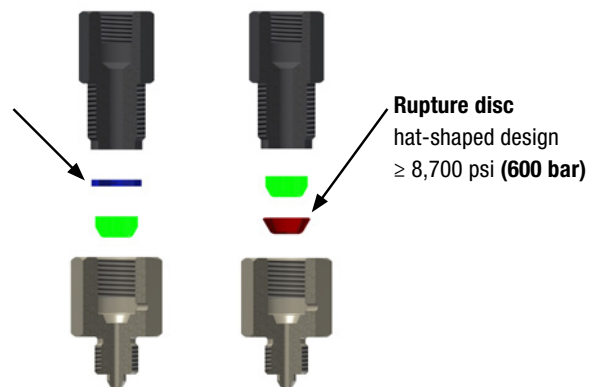

1/4" Rupture Discs

1/4" Rupture discs

1/4" angular and flat seat rupture discs are designed to be used with the safety head assemblies that are shown on page 13. Minimum rupture disc pressure ratings should be at least 110% of system operating pressure. The standard material is 1.4404 (SST 316L). The pressure ranges indicated in the table below are at room temperature (22°C/72°F).

Other materials and pressure ranges are available upon request.

Catalog Number	Pressure range psi (bar)
RD-1000-H2	970 - 1,060 (66.9 - 73.1)
RD-1200-H2	1,164 - 1,272 (80.3 - 87.7)
RD-1500-H2	1,455 - 1,590 (99.7 - 109.7)
RD-1750-H2	1,697 - 1,855 (117 - 127.9)
RD-2000-H2	1,940 - 2,120 (133.8 - 146.2)
RD-2500-H2	2,425 - 2,650 (167.2 - 182.8)
RD-3000-H2	2,910 - 3,180 (200.7 - 219.3)
RD-3500-H2	3,395 - 3,710 (234.1 - 255.9)
RD-4000-H2	3,880 - 4,240 (267.6 - 292.4)
RD-4500-H2	4,365 - 4,770 (301 - 329)
RD-5000-H2	4,850 - 5,300 (334.5 - 365.5)

Catalog Number	Pressure range psi (bar)
RD-5500-H2	5,335 - 5,830 (367.9 - 402.1)
RD-6000-H2	5,820 - 6,360 (401.4 - 438.6)
RD-6500-H2	6,305 - 6,890 (434.8 - 475.2)
RD-7000-H2	6,790 - 7,420 (468.3 - 511.7)
RD-7500-H2	7,275 - 7,950 (501.7 - 548.3)
RD-8000-H2	7,760 - 8,480 (535.2 - 584.8)
RD-8500-H2	8,245 - 9,010 (568.6 - 621.4)
RD-9000-H2	8,730 - 9,540 (602.1 - 657.9)
RD-9500-H2	9,215 - 10,070 (635.5 - 694.5)
RD-10000-H2	9,700 - 10,600 (669 - 731)
RD-11000-H2	10,670 - 11,660 (735.9 - 804.1)

Catalog Number	Pressure range psi (bar)
RD-12000-H2	11,640 - 12,720 (802.8 - 877.2)
RD-13000-H2	12,610 - 13,780 (869.7 - 950.3)
RD-14000-H2	13,580 - 14,840 (936.6 - 1023.4)
RD-15000-H2	14,550 - 15,900 (1,003.4 - 1,096.6)
RD-16000-H2	15,520 - 16,960 (1,070.3 - 1,169.7)
RD-17000-H2	16,490 - 18,020 (1,137.2 - 1,242.8)
RD-18000-H2	17,460 - 19,080 (1,204.1 - 1,315.9)
RD-19000-H2	18,430 - 20,140 (1,271 - 1,389)
RD-20000-H2	19,400 - 21,200 (1,337.9 - 1,462.1)
RD-21000-H2	20,370 - 22,260 (1,404.8 - 1,535.2)
RD-22000-H2	21,340 - 23,320 (1,471.7 - 1,608.3)



Rupture Discs are individually packed and marked type plate.

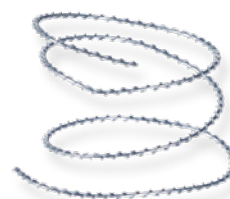

All dimensions are for reference only and are subject to change.

All technical and dimensional information subject to change. All general Terms and Conditions of sale, including limitations of our liability, apply to all products and services sold.

Medium Pressure Tubing

» Pressures to 22,500 psi (1,550 bar)

Medium Pressure Tubing

Maximator offers a line of cold drawn thick wall tubing, with flow areas to compliment the large orifice medium pressure valves and fittings. This tubing is made under strict manufacturing and quality control standards and inspections, with dimensional tolerances to match the requirements of the medium pressure coned and threaded connections.

The standard material is 1.4404 (SST 316L). Other materials may be provided on special request, depending on the specific material, diameters and lengths.



Tubing Tolerances

Normal Tubing Size in. (mm)	Tolerance O.D in. (mm)
1/4 (6.35)	0.248 / 0.243 (6.299 / 6.172)
3/8 (9.53)	0.370 / 0.365 (9.398 / 9.271)
9/16 (14.29)	0.557 / 0.552 (14.147 / 14.021)
3/4 (19.05)	0.745 / 0.740 (18.923 / 18.796)
1 (25.4)	0.995 / 0.990 (25.273 / 25.174)

Catalog Number	Tube Material	Fits Connection Type	Tube Size in. (mm)		Working Pressure psi (bar)				
			O.D.	I.D.	-325°F to 160°F (-193°C to 37°C)	200°F (93°C)	400°F (204°C)	600°F (315°C)	800°F (426°C)
21TU4M-316	1.4404 SST 316L	4MF	1/4	0.109 (2.77)	22,500 (1,550)	18,900 (1,300)	17,430 (1,200)	15,960 (1,100)	15,120 (1,040)
21TU6M-316		6MF	3/8	0.203 (5.17)	22,500 (1,550)	18,900 (1,300)	17,430 (1,200)	15,960 (1,100)	15,120 (1,040)
21TU9M-316		9MF	9/16	0.312 (7.93)	22,500 (1,550)	18,900 (1,300)	17,430 (1,200)	15,960 (1,100)	15,120 (1,040)
15TU9M-316		9MF	9/16	0.359 (9.12)	15,200 (1,050)	13,680 (940)	12,616 (870)	11,552 (790)	10,944 (750)
21TU12M-316		12M	3/4	0.438 (11.13)	22,500 (1,550)	18,900 (1,300)	17,430 (1,200)	15,960 (1,100)	15,120 (1,040)
15TU12M-316				0.516 (13.11)	15,200 (1,050)	13,680 (940)	12,616 (870)	11,552 (790)	10,944 (750)
21TU16M-316		16MF	1	0.562 (14.27)	22,500 (1,550)	18,900 (1,300)	17,430 (1,200)	15,960 (1,100)	15,120 (1,040)
15TU16M-316				0.688 (17.48)	15,200 (1,050)	13,680 (940)	12,616 (870)	11,552 (790)	10,944 (750)

All dimensions for reference only and are subject of change

All technical and dimensional information subject to change. All general Terms and Conditions of sale, including limitations of our liability, apply to all products and services sold.

Coned and Threaded Nipples

» Pressures to 22,500 psi (1,550 bar)

Coned and threaded nipples

Maximator offers a line of coned and threaded medium pressure tube nipples in a variety of lengths for all standard tube sizes. The coned and threaded medium pressure tube nipples are available in 1.4404 (SST 316L).

They are also available in the 15,200 psi (1,050 bar) or 22,500 psi (1,550 bar) versions for the 9/16", 3/4" and 1" OD tube sizes. See chart below for ordering information.

Special length coned and threaded nipples are available upon request. Consult Maximator for availability and price



Catalog Numbers are 1.4404 (SST 316L) material							Fits Connection Type	Tube Size in. (mm)		Working Pressure at 100°F psi (bar)
2.75" (69.85) Length	3" (76.2) Length	4" (101.6) Length	6" (152.4) Length	8" (203.2) Length	10" (254) Length	12" (304.8) Length		O.D.	I.D.	
21N4M-2.75-316	21N4M-3-316	21N4M-4-316	21N4M-6-316	21N4M-8-316	21N4M-10-316	21N4M-12-316	4MF	1/4	0.109 (2.77)	22,500 (1,550)
	21N6M-3-316	21N6M-4-316	21N6M-6-316	21N6M-8-316	21N6M-10-316	21N6M-12-316	6MF	3/8	0.203 (5.17)	22,500 (1,550)
		21N9M-4-316	21N9M-6-316	21N9M-8-316	21N9M-10-316	21N9M-12-316	9MF	9/16	0.312 (7.93)	22,500 (1,550)
		15N9M-4-316	15N9M-6-316	15N9M-8-316	15N9M-10-316	15N9M-12-316	9MF	9/16	0.359 (9.12)	15,200 (1,050)
			21N12M-6-316	21N12M-8-316	21N12M-10-316	21N12M-12-316	12MF	3/4	0.438 (11.13)	22,500 (1,550)
			15N12M-6-316	15N12M-8-316	15N12M-10-316	15N12M-12-316	12MF	3/4	0.516 (13.11)	15,200 (1,050)
			21N16M-6-316	21N16M-8-316	21N16M-10-316	21N16M-12-316	16MF	1	0.562 (14.27)	22,500 (1,550)
			15N16M-6-316	15N16M-8-316	15N16M-10-316	15N16M-12-316	16MF	1	0.688 (17.48)	15,200 (1,050)

Standard nipples are not supplied with glands and collars. For further available options and more detailed information please refer to our VFT catalogue.

All dimensions are for reference only and subject to change.

Tools

» Cone & Threading-Toolbox

VFT-ToolBoXX Type CTTB

The MAXIMATOR VFT-ToolBoXX Type CTTB provides order and clarity for your coning and threading tools.

The ToolBoXX is available in 3 versions:

Complete: tube dimension 1/4", 3/8" and 9/16" of the Medium, High and Ultra High Pressure series

Medium Pressure: tube dimension 1/4", 3/8" and 9/16" of the Medium series

High Pressure: tube dimension 1/4", 3/8" and 9/16" of the High and Ultra High Pressure series

By using a pre-formed foam inlay each tool has its defined place in the ToolBoXX:

- Coning tool, complete
- Collet chuck and cutting plate
- Threading tool complete and cutting oil
- Guide bushings and threading dies
- Deburring tool with 2 deburring heads
- Step-by-step instruction
- L-BoXX tool case, impact-resistant (ABS plastics)

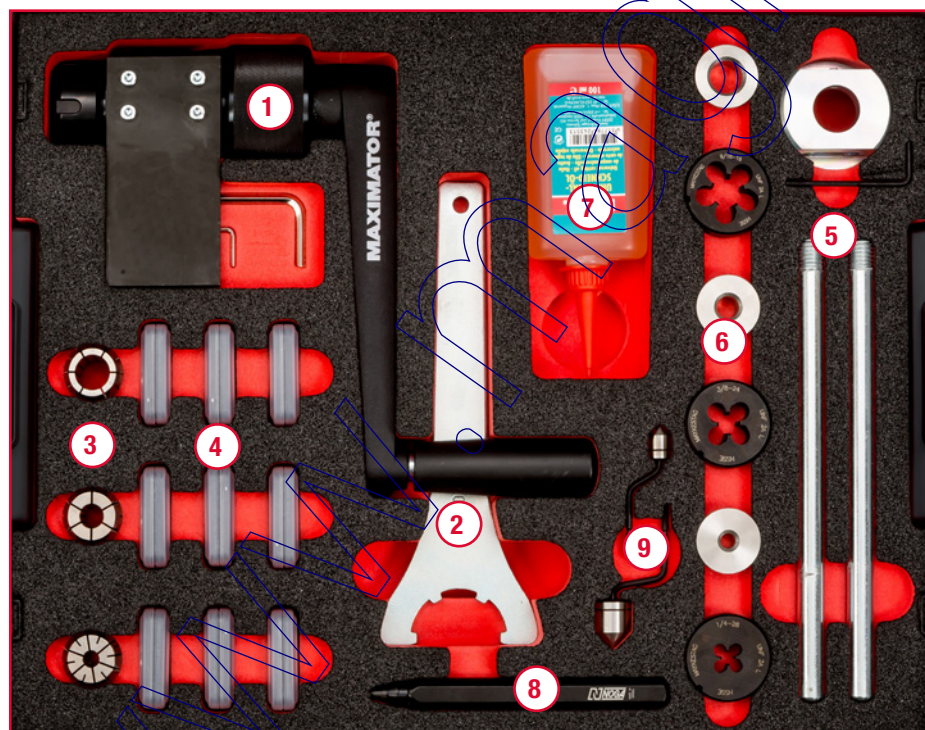

- 1 Coning tool
- 2 Chuck key
- 3 Collet chuck
- 4 Coning Blades
- 5 Threading tool
- 6 Guide bushing & threading dies
- 7 Cutting oil 100 ml
- 8 Deburring tool
- 9 Deburring head $\varnothing 10,4$ & $\varnothing 16,5$ mm

Catalogue key	Connection Type	Description
CTTB-M-H/U	-M -H/U	Medium, High and Ultra High Pressure
CTTB-M	-M	Medium Pressure
CTTB-H/U	-H/U	High and Ultra High Pressure

Gas boosters

» Type DLE

High pressure gas boosters – the Maximator concept

The Maximator high pressure gas boosters are suitable for the oil free compression of gases and air. Industrial gases like argon, helium, nitrogen and hydrogen can be compressed to operating pressures of 2,400 bar (36,000 psi) and oxygen up to 350 bar (5,075 psi), depending on the application. Air driven gas boosters are an efficient alternative instead of electrically driven products and can be used in explosion-proof areas (according to 2014/34/EU).

The Gas boosters in detail

Features at a glance

- » Pressure regulation via manual pressure regulator or pneumatically actuated valve
- » Operation with compressed air allows use in explosion-proof areas
- » Gas booster automatically stops operating upon reaching pre-selected final pressure
- » Gas booster restarts automatically to compensate leaks
- » No power consumption during long pressure holding periods
- » No heat generation during pressure holding period
- » Easy installation and trouble-free handling of gas boosters
- » Low maintenance thanks to reliable, easy-to-install devices
- » Effective cooling of the high pressure cylinders through integrated exhaust air cooling

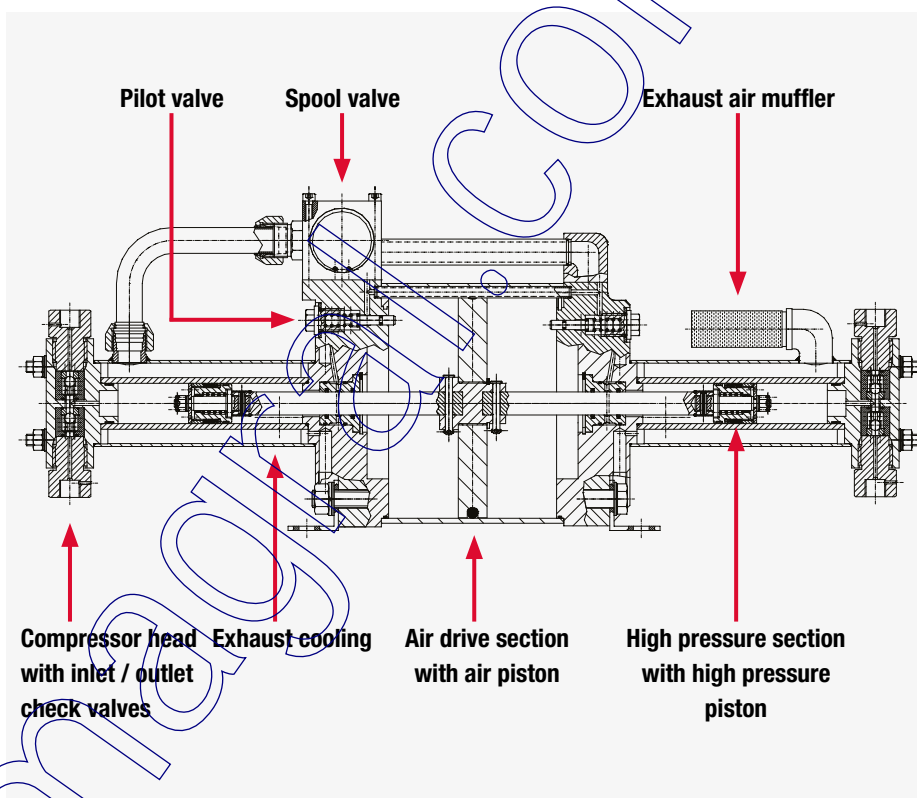

Function and operation

The Maximator gas boosters' operating principle is similar to a pressure intensifier. A large air piston is charged with low pressure (air piston) and works on a small area with high pressure (high pressure piston).

The continuous operation is achieved by a pilot operated 4/2 way valve (spool valve). The spool valve applies the drive air alternately to the upper and bottom surface of the air piston.

The spool is piloted through two 2/2 way valves (pilot valves) which are mechanically actuated through the air piston in its end positions. The pilot valves charge and discharge the spool chamber.

The high pressure piston supported by the check valves (inlet check valve and outlet check valve) delivers the flow.

The outlet pressure is directly related to the set air drive pressure. According to the formulas indicated in the technical features table for the gas boosters, the static end pressure can be calculated.

At this pressure a force balance between drive section and gas section is achieved. The booster stalls when this end pressure is reached, and does not consume any further air.

A pressure drop at the high pressure side or a pressure increase at the drive side starts the booster automatically until the force balance is achieved again.

Additionally the Maximator boosters can be switched on and off automatically through Maximator air pilot switches, contact gauges or external control devices.

Notice:

Purging plans for compression of combustible gases using Maximator gas boosters are explained in detail in the operators manual available on our website www.maximator.de.

» Product range overview

The series and its functions

Maximator gas boosters offer the right solution for every application. As a result of the wide range of models it is possible to select the optimum booster for each application. Single stage or two stage boosters, single acting, double acting, quadruple acting or a combination of these models can be used to achieve different operating pressures and flow capacities. They are suitable for different or stepped flow rates as well as for different maximum allowable operating pressures. In addition to gas boosters with a Ø 160 mm drive (DLE series), Maximator also offers various models with a Ø 200 mm drive (8DLE series) for high volume flows.

160 mm - Drive (Standard DLE-Series):

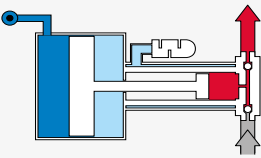
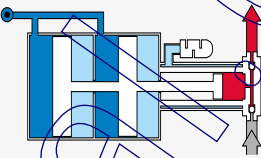
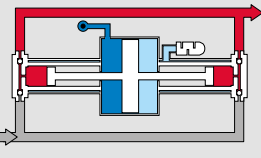
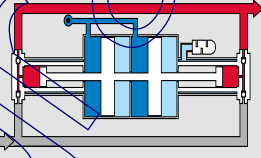
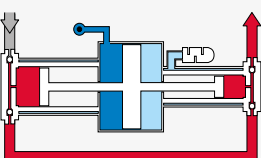
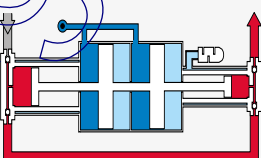
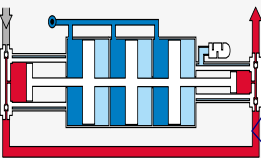
One Air Drive Section		Two Air Drive Sections	
Pattern	Design Pressure ratio max. working pressure Type	Pattern	Design Pressure ratio max. working pressure Type
	Single stage - single acting from 1:2 up to 1:75 max. 750 bar DLE 2-1, DLE 5-1, DLE 15-1, DLE 30-1, DLE 75-1		Single stage - single acting from 1:4 up to 1:150 max. 1,500 bar DLE 2-1-2, DLE 5-1-2, DLE 15-1-2, DLE 30-1-2, DLE 75-1-2
	Single stage - double acting from 1:2 up to 1:75 max. 1,500 bar DLE 2, DLE 5, DLE 15, DLE 30, DLE 75		Single stage - double acting from 1:4 up to 1:150 max. 1,500 bar DLE 2-2, DLE 5-2, DLE 15-2, DLE 30-2, DLE 75-2
	Two stage from 1:2 / 1:5 up to 1:30 / 1:75 max. 1,500 bar DLE 2-5, DLE 5-15, DLE 5-30, DLE 15-30, DLE 15-75, DLE 30-75		Two stage - double acting from 1:4/1:10 up to 1:60/1:150 max. 2,100 bar DLE 2-5-2, DLE 5-15-2, DLE 5-30-2, DLE 15-30-2, DLE 15-75-2, DLE 30-75-2
Three Air Drive Sections			
	Two stage - double acting 1:30 / 1:75 max. 2,400 bar DLE 30-75-3		

200 mm - Drive (8DLE-Series for high volume flow applications):

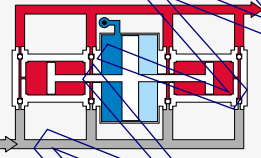
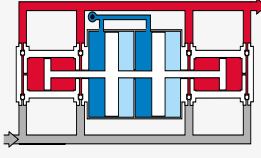
One Air Drive Section	Two Air Drive Sections
	
Single stage - quadruple acting 1:1,65 max. 300 bar 8DLE 1,65	Single stage - quadruple acting 1:3 max. 40 bar 8DLE 3

For further available options and more detailed information please refer to our Gas Booster catalogue.

» Flow capacity

The flow capacity of gas boosters mainly depends on the air drive pressure and, in the case of double-acting or two-stage devices, also on the gas inlet pressure. Detailed performance curves can be found in the data sheets for the various gas booster types at www.maximator.de. The flow capacity tables shown here contain rounded values and are used to compare the gas booster types. Please consult Maximator to determine the expected performance characteristics for a specific application.

Type	$p_L = 6 \text{ bar}$			Type	$p_L = 6 \text{ bar}$			Type	$p_L = 5 \text{ bar}$		
	p_A [bar]	p_B [bar]	Q [l _n /min]		p_A [bar]	p_B [bar]	Q [l _n /min]		p_A [bar]	p_B [bar]	Q [l _n /min]
DLE 2-1	2	5	120	8DLE 6	6	40	230	DLE 15-1	34	40	240
DLE 2-1	2	8	85	DLE 5-15-2	6	70	75	DLE 15	34	40	500
DLE 5-30	2	40	55	DLE 5-15	6	70	100	DLE 15-1	34	70	130
DLE 5-30	2	120	40	DLE 5-15-2	6	120	60	DLE 15-1-2	34	70	213
DLE 5-30	3	40	75	DLE 5-30-2	6	120	75	DLE 15-2	34	70	390
DLE 5-30	3	120	55	DLE 5-30-2	6	210	65	DLE 15	34	70	400
DLE 2-1	4	5	200	DLE 5-1	10	15	180	DLE 15-30-2	34	120	130
DLE 2	4	5	400	DLE 5-1-2	10	15	210	DLE 15-1-2	34	120	150
DLE 2-1	4	8	145	DLE 5-2	10	15	390	DLE 15-2	34	120	300
DLE 2-5	4	8	180	DLE 5	10	15	405	DLE 30-75	34	210	115
DLE 2-1-2	4	8	210	DLE 5-1	10	25	80	DLE 15-30-2	34	350	60
DLE 2	4	8	340	DLE 5	10	25	300	DLE 30-75-2	34	350	60
8DLE 3	4	8	1060	DLE 5-1-2	10	40	140	DLE 30-75	34	350	90
DLE 5-1	4	15	80	DLE 5-2	10	40	275	DLE 30-75-2	34	600	50
DLE 5-1-2	4	15	95	DLE 5-15-2	10	70	120	8DLE 1,65	50	53	9900
DLE 2-5-2	4	15	125	DLE 5-15-2	10	120	105	8DLE 1,65	50	56	7540
DLE 2-1-2	4	15	155	DLE 15-75	10	210	70	DLE 30-1	50	70	180
DLE 5	4	15	160	DLE 15-75	10	350	45	DLE 30	50	70	355
DLE 5-2	4	15	165	DLE 15-1	15	40	110	DLE 30-1	50	120	130
DLE 2-2	4	15	300	DLE 15	15	40	200	DLE 30-1-2	50	120	170
8DLE 6	4	15	530	DLE 15-1	15	70	60	DLE 15-30-2	50	120	195
8DLE 3	4	15	840	DLE 15-1-2	15	70	95	DLE 30-2	50	120	285
DLE 5-1	4	25	35	DLE 15-30	15	70	105	DLE 30	50	120	290
DLE 2-2	4	25	85	DLE 15	15	70	130	DLE 30-1-2	50	210	140
DLE 5	4	25	90	DLE 15-2	15	70	165	DLE 30-2	50	210	225
DLE 2-5	4	25	175	DLE 15-1-2	15	120	65	DLE 15-30-2	50	350	115
DLE 5-1-2	4	40	65	DLE 15-30	15	120	90	DLE 75-1	75	210	100
DLE 5-15	4	40	90	DLE 15-2	15	120	115	DLE 75	75	210	205
8DLE 6	4	40	100	DLE 15-75	15	210	100	DLE 75-1	75	350	55
DLE 5-2	4	40	105	DLE 15-75-2	15	350	55	DLE 75-1-2	75	350	100
DLE 2-5-2	4	40	105	DLE 15-75	15	350	75	DLE 75	75	350	135
DLE 5-15	4	70	65	DLE 15-75-2	15	600	45	DLE 30-75-2	75	350	140
DLE 5-30-2	4	120	55	8DLE 1,65	22	25	4480	DLE 75-2	75	350	155
DLE 5-30-2	4	210	45	8DLE 1,65	22	30	1995	DLE 75-1-2	75	600	70
DLE 2-5	6	8	250	DLE 30-1	22	70	80	DLE 75-2	75	600	110
DLE 2-1-2	6	8	300	DLE 30	22	70	145	DLE 30-75-2	75	600	120
DLE 2	6	8	535	DLE 15-30	22	70	155	DLE 75-1	115	210	155
DLE 2-1-2	6	15	220	DLE 30-1	22	120	55	DLE 75	115	210	330
DLE 2	6	15	220	DLE 30-1-2	22	120	80	DLE 75-1	115	350	85
DLE 2-2	6	15	460	DLE 30	22	120	105	DLE 75-1-2	115	350	150
8DLE 6	6	15	750	DLE 30-2	22	120	120	DLE 75	115	350	240
8DLE 3	6	15	1300	DLE 15-30	22	120	140	DLE 75-2	115	350	245
DLE 2-5-2	6	25	180	DLE 30-1-2	22	210	60	DLE 75-1-2	115	600	105
DLE 2-2	6	25	190	DLE 30-75	22	210	70	DLE 75-2	115	600	180
8DLE 3	6	25	195	DLE 30-2	22	210	90	DLE 30-75-3	120	1000	120
DLE 2-5	6	25	245	DLE 30-75	22	350	50	DLE 30-75-3	120	1600	15
DLE 5-15	6	40	125	DLE 15-75-2	22	350	80	DLE 30-75-3	170	1000	185
DLE 2-5-2	6	40	160	DLE 15-75-2	22	600	70	DLE 30-75-3	170	1600	60

p_L = Air drive pressure
 p_A = Gas inlet pressure

p_B = Working pressure
 Q = Flow capacity at working point

» Overview of technical features and connections

Type	Stroke volume [cm ³]	max. working pressure p _B [bar]	max. compression ratio e	pressure ratio i	max. operating temperature T [°C]	gas inlet pressure		Connections		Recommended pipe internal diameter		
						min. p _A [bar]	max. p _A [bar]	Inlet A	Outlet B	p _L [mm]	p _A [mm]	p _B [mm]
DLE 2-1	922	20	1:10	1:2	60	0	20	G 1/2	G 1/2	19	13	13
DLE 5-1	373	50	1:15	1:5	60	2	50	G 1/2	G 1/2	19	13	13
DLE 15-1	122	150	1:20	1:15	100	7	150	G 1/4	G 1/4	19	6	4
DLE 30-1	60	300	1:20	1:30	100	15	300	G 1/4	G 1/4	19	6	4
DLE 75-1	25	750	1:20	1:75	100	35	750	G 1/4	G 1/4	19	6	4
DLE 2-1-2	922	40	1:10	1:4	60	0	40	G 1/2	G 1/2	19	13	13
DLE 5-1-2	373	100	1:15	1:10	60	4	100	G 1/2	G 1/2	19	13	13
DLE 15-1-2	122	300	1:20	1:30	100	10	300	G 1/4	G 1/4	19	6	4
DLE 30-1-2	60	600	1:20	1:60	100	20	600	G 1/4	G 1/4	19	6	4
DLE 75-1-2	25	1500	1:20	1:150	100	45	1500	G 1/4	G 1/4	19	6	4
DLE 2	1844	40	1:10	1:2	60	0	40	G 1/2	G 1/2	19	13	13
DLE 5	746	100	1:15	1:5	60	2	100	G 1/2	G 1/2	19	13	13
DLE 15	244	300	1:20	1:15	100	7	300	G 1/4	G 1/4	19	6	4
DLE 30	120	600	1:20	1:30	100	15	600	G 1/4	G 1/4	19	6	4
DLE 75	50	1500	1:20	1:75	100	35	1500	G 1/4	G 1/4	19	6	4
DLE 2-2	1844	40	1:10	1:4	60	0	40	G 1/2	G 1/2	19	13	13
DLE 5-2	746	100	1:15	1:10	60	4	100	G 1/2	G 1/2	19	13	13
DLE 15-2	244	300	1:20	1:30	100	10	300	G 1/4	G 1/4	19	6	4
DLE 30-2	120	600	1:20	1:60	100	20	600	G 1/4	G 1/4	19	6	4
DLE 75-2	50	1500	1:20	1:150	100	45	1500	G 1/4	G 1/4	19	6	4
DLE 2-5	922	70	1:25	1:2/1:5	60	0	0,8 x p _L	G 1/2	G 1/2	19	13	13
DLE 5-15	373	198	1:45	1:5/1:15	100	2	1,6 x p _L	G 1/2	G 1/4	19	13	4
DLE 5-30	373	330	1:90	1:5/1:30	100	2	0,5 x p _L	G 1/2	G 1/4	19	13	4
DLE 15-30	122	450	1:40	1:15/1:30	100	7	7,5 x p _L	G 1/4	G 1/4	19	6	4
DLE 15-75	122	875	1:100	1:15/1:75	100	7	2,5 x p _L	G 1/4	G 1/4	19	6	4
DLE 30-75	60	1050	1:50	1:30/1:75	100	15	12 x p _L	G 1/4	G 1/4	19	6	4
DLE 2-5-2	922	100	1:25	1:4/1:10	60	0	1,6 x p _L	G 1/2	G 1/2	19	13	13
DLE 5-15-2	373	300	1:45	1:10/1:30	100	2	3,2 x p _L	G 1/2	G 1/4	19	13	4
DLE 5-30-2	373	600	1:90	1:10/1:60	100	2	1 x p _L	G 1/2	G 1/4	19	13	4
DLE 15-30-2	122	600	1:40	1:30/1:60	100	7	15 x p _L	G 1/4	G 1/4	19	6	4
DLE 15-75-2	122	1500	1:100	1:30/1:150	100	7	5 x p _L	G 1/4	G 1/4	19	6	4
DLE 30-75-2	60	1500	1:50	1:60/1:150	100	15	24 x p _L	G 1/4	G 1/4	19	6	4
DLE 30-75-3	60	2400	1:50	1:90/1:225	100	30	30 x p _L	G 1/4	4H	19	6	4
8DLE 1,65	4100	100	1:10	1:1,65	100	0	100	G 1/2	G 1/2	19	13	13
8DLE 3	4100	40	1:15	1:3,3	60	0	40	G 1/2	G 1/2	19	13	13
8DLE 6	2050	40	1:15	1:6,6	60	0	40	G 1/2	G 1/2	19	13	13

p_L = Air drive pressure
p_A = Gas inlet pressure

p_B = Working pressure
i = Pressure ratio

e = Compression ratio (e = p_B/p_A)

At your side, everywhere

With our international partner companies, experienced experts in high-pressure technology are always ready to assist you. We have compiled detailed contact information for our international partners which you can find on our website at:

www.maximator.de/worldwide+distribution.

MAXIMATOR GmbH

Lange Strasse 6, 99734 Nordhausen Germany

Telephone +49 (0) 3631 9533 – 0

Telefax +49 (0) 3631 9533 – 5010

info@maximator.de

» Visit our Website:
» www.maximator.de