

**COMPACT**<sup>®</sup>  
AUTOMATION PRODUCTS

## Angular and Parallel Grippers

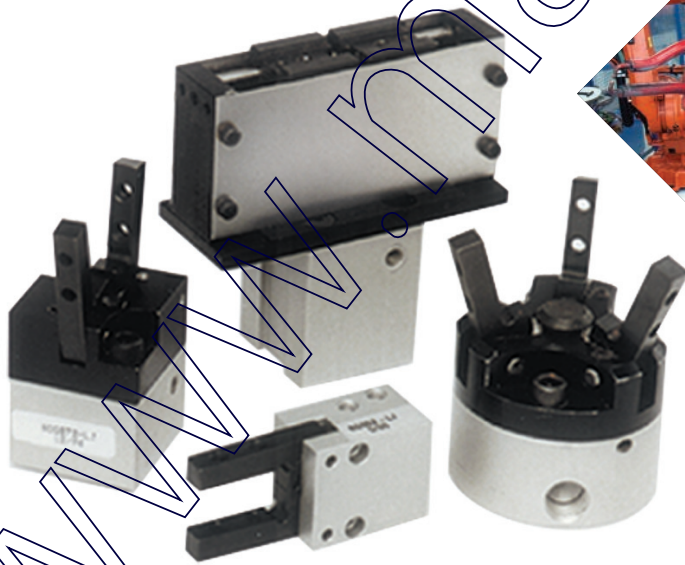

# Table of Contents: Grippers

## Angular Grippers, Parallel Grippers and Options & Accessories

### Angular Grippers

Introduction .....	pg. 2
How to Order: Angular Grippers .....	pg. 3
Engineering Data .....	pg. 4
Forces .....	pg. 4-5
<b>Dimensions</b>	
Cylinders .....	pg. 6-10
Accessories .....	pg. 11-12

### Parallel Grippers

Introduction .....	pg. 13
How to Order: Parallel Grippers .....	pg. 14
Engineering Data .....	pg. 15
Forces .....	pg. 15-16
<b>Dimensions</b>	
Cylinders .....	pg. 17-18
Accessories .....	pg. 19

### Angular and Parallel Grippers Options and Accessories

Adjustable Jaw Travel .....	pg. 20
Sensors .....	pg. 21-23
Seal Options .....	pg. 24
Application Ideas .....	pg. 24

3-D Models available online at [www.compactautomation.com](http://www.compactautomation.com)

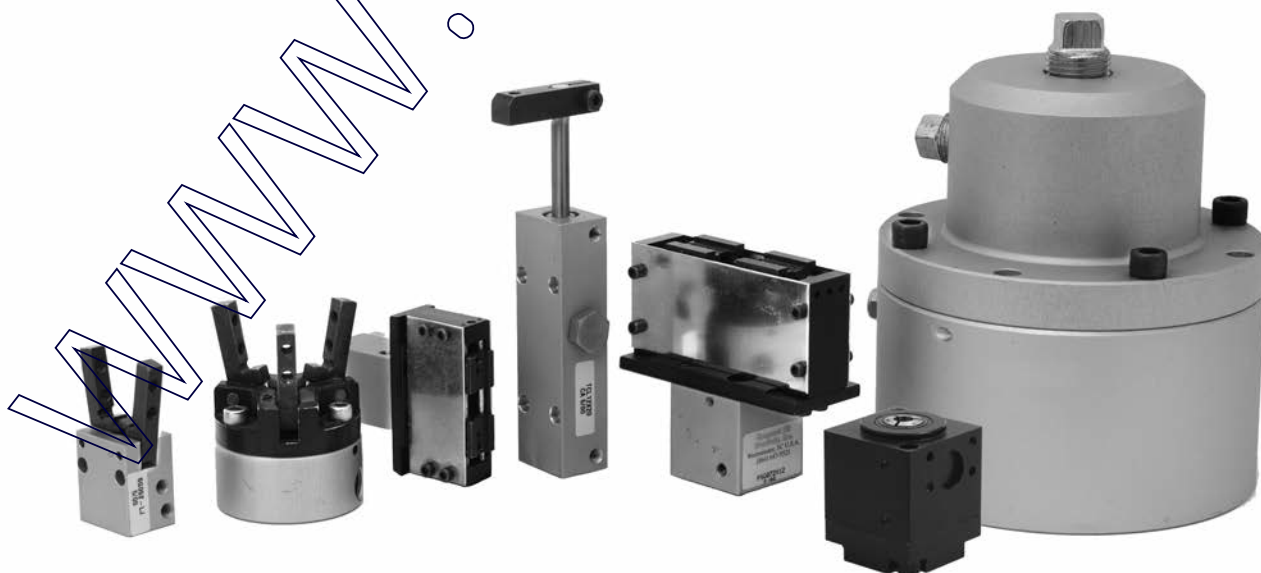

# Introduction

**Com-Pick** grippers are designed for use in industrial applications such as robotics, pick-n-place, automated assembly, and manipulator/tooling. All units feature a self-contained, double-acting actuator. Grippers can be mounted to any manufacturer's robot, manipulator or actuator by way of an adapter flange. Low unit weight, high output and compact size are features of all models. Special materials, tooling, and adapter flanges are available upon request.

Seal options, jaw options, sensor options, etc., can be easily added at assembly for prompt delivery of all variations.

Angular motion grippers represent the lowest cost design. The air cylinder is an integral component of the overall gripper length. The piston actuator pushes the cam, or yoke, forward, rocking/pivoting the jaws open. The pull stroke closes the jaws. A four-way valve circuit is required for control.

Both two and three jaw designs are offered. Round and square body styles are standard.

Gripping force formulas, unit weights, and dimensions are included in the following sections.

- UNIQUE PATENTED DESIGN •
- PREMIUM QUALITY •
- PROMPT DELIVERY •



All products manufactured under 1 or more of the following US patents: # 4,167,134...#4,492,400...  
#4,566,727...#4,723,803...#4,723,806...#4,903,933...#4,924,758...#5,070,767...#5,113,746...#5,117,743...#5,135,329...#5,245,911...#5,437,440...#5,456,161...#5,479,  
956...#5,522,302...#89 904 344.3-2301.

Other US and Foreign patents pending. The specifications in this bulletin are believed to be accurate and reliable. However, it is the responsibility of the product user to determine the suitability of Compact Automation's products for a specific application. While products found by Compact Automation to be defective will be replaced, no liability is assumed beyond such replacement. Specifications subject to change without notice. Compact, Husky, Snap-Cap, Clean Act, Comtronic, and World Class are all registered trademarks of Compact Automation Products, Inc.

# How to Order: Angular Grippers

Angular Grippers Example: ASG072-1

MAGNETIC PISTON OPTION ONLY	GRIPPER STYLE	SIZE AND NUMBER OF JAWS	JAW OPTIONS	OPTION	OPTION
A	SG	072	1	XXX	XXX
1	2	3	4	5	5

**1 Magnetic Piston Option Only**

<b>A</b>	For Magnetic Piston option only. See sensor pages 21-23. Omit if not desired
----------	--

**2 Gripper Style**

<b>*SG</b>	Square End Mount
<b>* **BG</b>	Square Side Mount
<b>**RG</b>	Round Body End Mount
*NOTE: Not available in 3 jaw	
**NOTE: Not available on 1/2 bore	

**3 Size and Number of Jaws**

Bore	2 Jaw	3 Jaw
1/2"	052	--
3/4"	072	073
1-1/8"	112	113
1-5/8"	162	163
2"	202	--
2-1/2"	252	253
3"	302	303
4"	402	403
4"	412	--
5"	502	503
6"	602	603
8"	802	803

**4 Jaw Options**

--	No jaws required - simply omit code
--	Blank jaws required, specify length - see page 11
<b>LJ</b>	Premodified jaws required - see page 12

**5 Options**

--	Simply omit codes if no options or accessories are desired
<b>ADJ</b>	Adjustable Jaw Closing
<b>HTV</b>	High Temperature Viton Seals
<b>CRT*</b>	Corrosion Resistant Teflon Seals
<b>PA</b>	Positive Alignment Pilot. See page 11.
*NOTE: Not available on 1/2" bore models	

**Modifications Welcome**

Special stroke lengths, port orientation, mounting configuration.

# Angular Motion Grippers - Com-Pick Pneumatic Grippers 2 & 3 Jaw

## Engineering Data

### Self Contained Actuator

Cylinders feature low profiles, low weight aluminum alloy bodies, and stainless steel piston rods. All units are prelubricated for life.

### Actuator Seals

As standard, actuators contain Buna-N rubber. Temperature limits are from 0°F to 200°F (-18°C to 90°C). All actuators are prelubricated at the factory and do not require additional lubrication. Seal options — page 24.

### Materials

Actuators are aluminum alloy with bronze rod bushings. Pivot head is anodized aluminum for low weight and high strength. Jaws, if purchased are "1018" steel in soft form. Pivot joints are hardened and ground dowel pins.

### Tooling

Com-Pick grippers are "generic" in standard form. You can make your own jaws (pivot drawing available on request), purchase our soft blank or pre-modified "L" jaws, add "V" blocks, pads, sensors, etc. Also, see page 12.

## Theoretical Gripping Force Formulas — 2 Jaw Type (Pre-calculated reference — next page.)

$072 = \frac{F \times .437}{.187 + X}$	$112 = \frac{F \times .562}{.234 + X}$	$162 = \frac{F \times .750}{.281 + X}$
$202 = \frac{F \times .937}{.281 + X}$	$252 = \frac{F \times 1.187}{.469 + X}$	$302 = \frac{F \times 1.437}{.469 + X}$
$402 = \frac{F \times 1.875}{.578 + X}$	$412 = \frac{F \times 2.375}{.578 + X}$	$502 = \frac{F \times 2.375}{.578 + X}$
$602 = \frac{F \times 2.375}{.625 + X}$	$802 = \frac{F \times 2.75}{.812 + X}$	

"X" Distance From Gripper Face to Centerline of Grippled Part

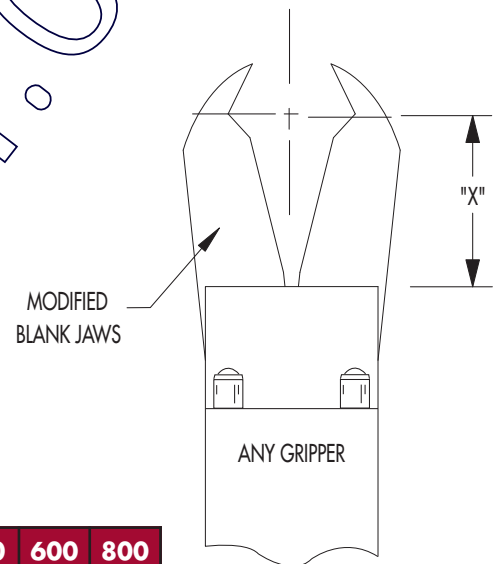

"F" Cylinder Output (Piston Area x PSI)

	Series	070	110	160	200	250	300	400	500	600	800
Piston Area (IN <sup>2</sup> )	Bore Action	3/4	1-1/8	1-5/8	2	2-1/2	3	4	5	6	8
	Push Open	.4	1	2	3	5	7	12.5	19.6	28.3	50.3
	Pull Close	.6	.8	1.7	2.7	4.5	6.5	12	19.2	27.5	49.5

Theoretical Gripping Force Formula — 3 Jaw Type (Pre-calculated reference — next page.)

Use formula's above, then multiply by % below

Series	073	113	163	253	303	403	503	603	803
%	72%	57%	79%	85%	70%	80%	78%	100%	100%



# Angular Motion Grippers - Com-Pick Pneumatic Grippers 2 & 3 Jaw

## Engineering Data — Continued

### Pressure Ratings

<b>Pneumatic</b>	Clean, dry or lubricated — 5 PSI to 200 PSI
<b>Hydraulic</b>	Consult factory

### 2 Jaw Pre-Calculated Gripping Forces (lbs)

Nominal jaw lengths (Materials "1018" steel) Standard lengths listed on page 11												
Calculations below are theoretical, figured @ 100 PSI - Jaw length equals "X" variable in formula on previous page												
Jaw Length		072	112	162	202	252	302	402	412	502	**602	**802
1"	Open	14	45	117	219	404	684	1485	1881	2949	4136	7633
	Close	13	36	99	197	363	635	1425	1806	2889	4019	7512
2"	Open	8	25	65	123	240	407	909	1151	1805	2560	4919
	Close	7	20	55	110	216	378	872	1105	1768	2488	4840
3"	Open	5	17	45	85	171	289	655	829	1301	1854	3628
	Close	4	13	38	77	153	269	628	796	1274	1801	3570
4"	Open	*	*	35	65	132	225	511	648	1016	1453	2874
	Close	*	*	29	59	119	209	491	622	996	1412	2828
5"	Open	*	*	*	53	108	183	420	532	834	1194	2379
	Close	*	*	*	47	97	170	403	510	817	1161	2342

NOTES: Gripping force is constant at any position of opening. If using 80 PSI, multiply above by 80%, 125 PSI multiply by 125%.

\* Long tooling not recommended on small grippers.

\*\* Not standard items.

### 3 Jaw Pre-Calculated Gripping Forces

Multiply above forces by % given below

Series	073	113	163	253	303	403	503	603	803
%	72%	57%	79%	85%	70%	80%	78%	100%	100%

### Estimated Unit Weights (without Jaws) (lbs)

Series	07	11	16	20	25	30	40	41	50	60	80
<b>2 Jaw</b>	.28	.50	1.2	1.75	3.0	4.0	7.8	9.0	10.8	N/A*	N/A*
<b>3 Jaw</b>	.30	.49	1.0	--	2.5	3.7	7.2	--	10.0	N/A*	N/A*

\*Consult factory

### Double Rod End Actuators

All **Com-Pick** Grippers are available with a double rod end actuator. (Part Nos. "RDG," "SDG" and "BDG"). The double rod end actuator allows indication of jaw position via limit switch or proximity switch.

Example: As jaws open — the rod retracts. As the jaws close, the rod extends.

Rod travel is variable depending on unit size. Also see Comtronic Sensors pages 21-23.

# Angular Grippers: 2 Jaw - 1/2" Bore Snap Cap Design

## Rectangular Body Gripper "SG" (End Mounted and Base Mounted)

Gripper shown with 1" jaws - available with or without jaws

Design features three standard mounting patterns

**Pressure Rating:** 3 to 125 PSI  
Clean, dry or lubricated air (air only)

**Estimated Unit Weight:**  
SG052 = .08 lbs. / ASG052 = .11 lbs

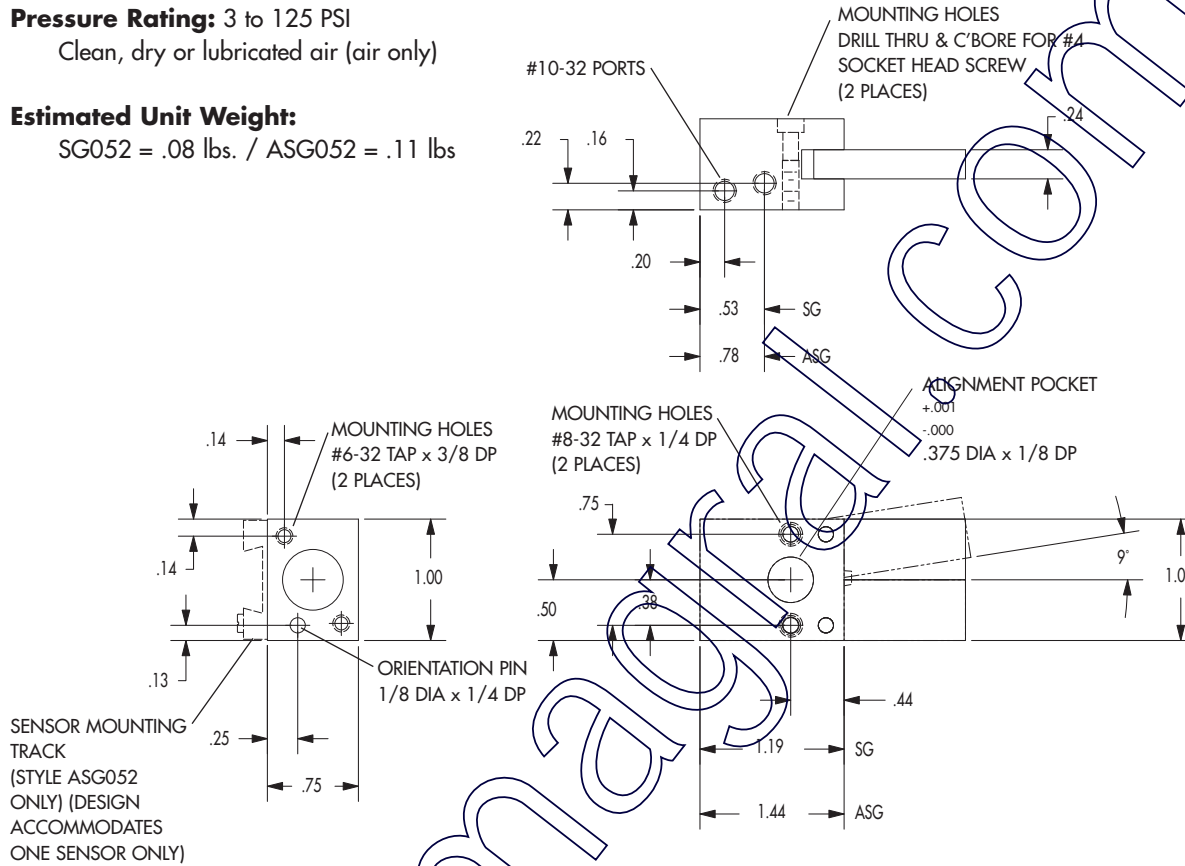
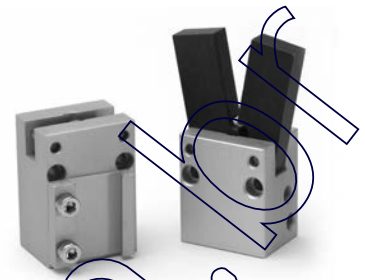

SENSOR MOUNTING TRACK (STYLE ASG052 ONLY) (DESIGN ACCOMMODATES ONE SENSOR ONLY)

All Dimensions in Inches

### Engineering Data

**G<sub>f</sub>** = Gripping force  
**A** = Distance from gripper face to centerline of gripped part (see sketch)

### Theoretical Gripping Force Formula

$$G_f = \frac{F \times .375}{.156 + A}$$

Action	Piston Area In. <sup>2</sup>
Push / Open	.2
Pull / Close	.15

Quick Reference Chart		
Dimension "A"	Action	Pre-Calculated Gripping Force At 100 PSI (G <sub>f</sub> )
1/2"	Push / Open	11.43 lbs.
	Pull / Close	8.57 lbs.
1"	Push / Open	6.48 lbs.
	Pull / Close	4.86 lbs.
2"	Push / Open	3.47 lbs.
	Pull / Close	2.61 lbs.

**Note:** Tooling over 2" long is not recommended

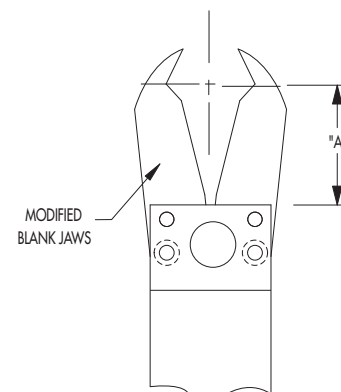

# Angular Grippers: 2 Jaw

## Round Body Gripper "RG"

## Round Body Gripper with Double Rod "RDG"

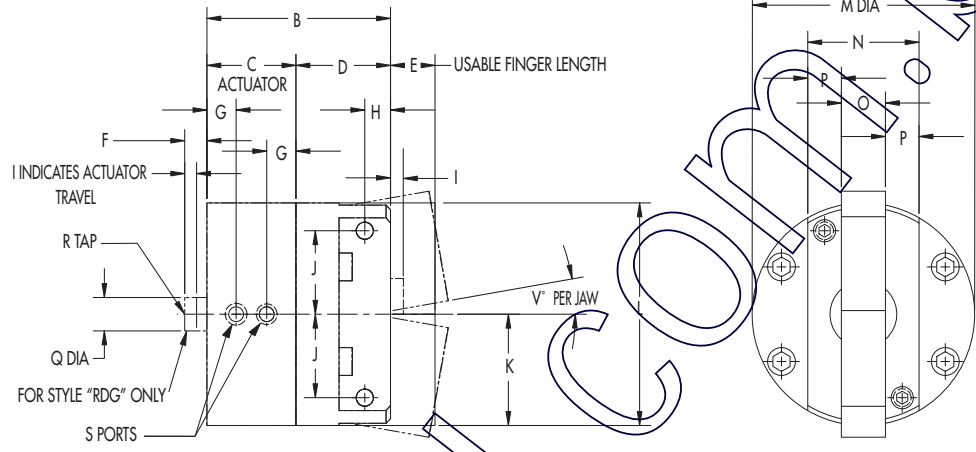
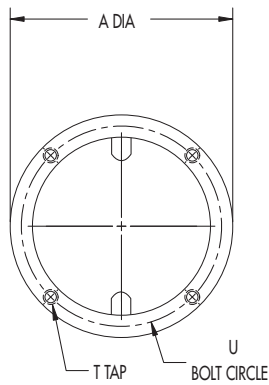

Bore	Part #	A	B	C	D	E	F	G	H	I	J	K	L	M	N	O	P	Q	R	S	T	U	V°
3/4"	072	1-1/2"	1-9/16"	7/8"	11/16"		3/16"	9/32"	3/16"	1/8"	7/16"	5/8"	1-1/4"	1-1/2"	29/32"	.240	21/64"	5/16"	10-24 x 1/2"	* 10-32	10-24 x 7/16	1-1/8"	14°
1-1/8"	112	1-7/8"	1-7/8"	7/8"	1"		1/4"	9/32"	15/64"	1/8"	9/16"	3/4"	1-1/2"	1-7/8"	1-5/32"	.365	25/64"	1/2"	5/16-18 x 5/8"	1/8-27	10-24 x 7/16	1-1/2"	10°
1-5/8"	162	2-3/8"	2-7/16"	1-1/8"	1-5/16"		1/4"	13/32"	9/32"	1/8"	3/4"	1"	2"	2-3/8"	1-15/32"	.490	31/64"	5/8"	3/8-16 x 7/8"	1/8-27	10-24 x 7/16	2"	8°
2"	202	3"	2-11/16"	1-3/8"	1-5/16"		3/8"	7/16"	9/32"	1/4"	15/16"	1-1/4"	2-1/2"	3"	1-1/4"	.490	3/8"	5/8"	3/8-16 x 7/8"	1/8-27	1/4-20 x 5/8"	2-1/2"	14°
2-1/2"	252	3-1/2"	3-1/4"	1-1/2"	1-3/4"	SEE NOTE NUMBER 2 BELOW	3/8"	1/2"	15/32"	1/4"	1-3/16"	1-1/2"	3"	3-1/2"	2-1/32"	.615	45/64"	3/4"	1/2-13 x 1"	** 1/8-27	1/4-20 x 5/8"	3"	11°
3"	302	4"	3-1/2"	1-3/4"	1-3/4"		3/8"	9/16"	15/32"	1/4"	1-7/16"	2"	4"	4"	2"	.615	11/16"	3/4"	1/2-13 x 1-1/8"	** 1/8-27	5/16-18 x 3/4"	3-1/2"	9°
4"	402	5"	4-1/8"	2"	2-1/8"		1/2"	21/32"	37/64"	3/8"	1-7/8"	2-1/2"	5"	5"	2-1/2"	.990	3/4"	3/4"	1/2-13 x 1-5/16"	** 1/8-27	5/16-18 x 3/4"	4-1/2"	10°
4"	412	5"	4-1/8"	2"	2-1/8"		1/2"	21/32"	37/64"	3/8"	2-3/8"	3"	6"	6"	2-1/2"	.990	3/4"	3/4"	1/2-13 x 1-5/16"	** 1/8-27	5/16-18 x 3/4"	4-1/2"	8°
5"	502	6"	4-1/4"	2-1/8"	2-1/8"		1/2"	21/32"	37/64"	3/8"	2-3/8"	3"	6"	6"	2-1/2"	.990	3/4"	3/4"	1/2-13 x 1-3/8"	** 1/8-27	5/16-18 x 3/4"	5-1/2"	8°
6"	602	SEE NOTE #4 BELOW																					
8"	802	SEE NOTE #4 BELOW																					

\*1/8-27 Pipe Tap Optional

\*\*1/4-18 Pipe Tap Optional

### Notes:

#1	Ports are 180° apart. Consult factory for other Port locations. Head can be indexed 90°.
#2	See chart on Page 11 for standard jaw lengths. Standard jaws are in blank form to be modified. Specials welcome.
#3	Gripping force calculations on pages 4 & 5.
#4	Due to a different pivot design on "602" & "802" sizes, above tabulated drawing does not apply. Consult factory for drawings.

All Dimensions in Inches



# Angular Grippers: 2 Jaw

## Square Body Gripper "SG"

## Square Body Gripper With Double Rod "SDG"

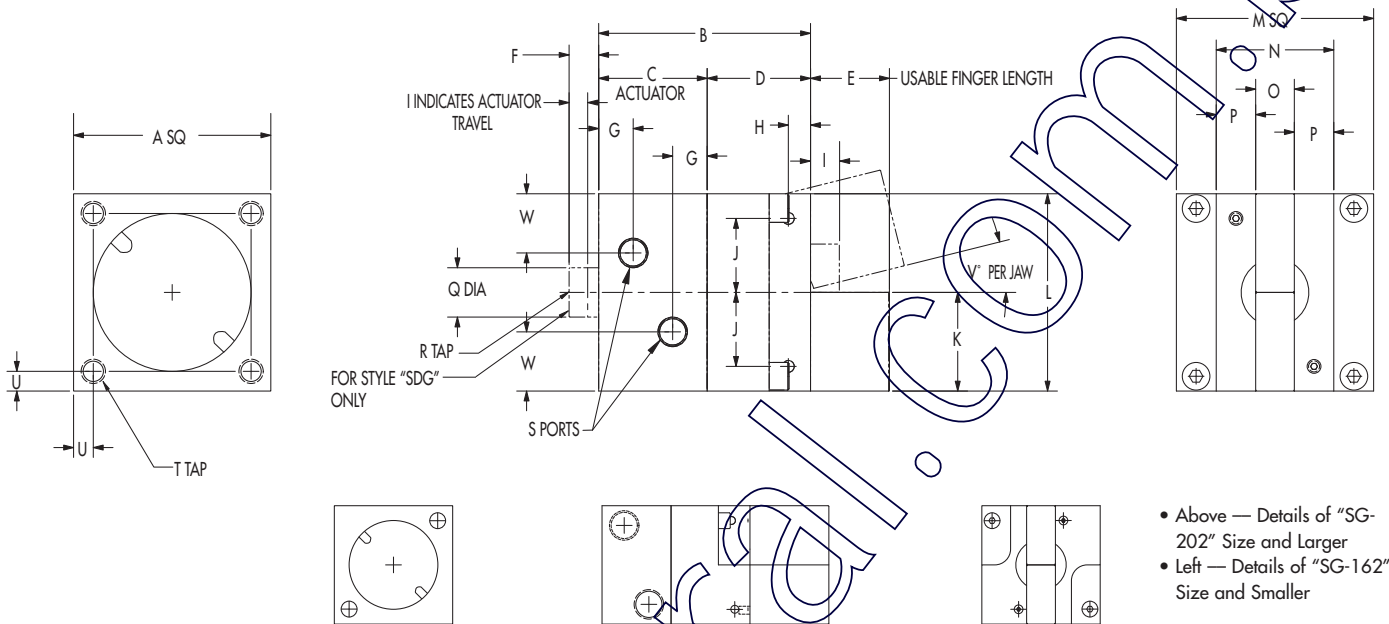

(NOTE: Port Locations and Mounting Pattern)

- Above — Details of "SG-202" Size and Larger
- Left — Details of "SG-162" Size and Smaller

Bore	Part #	A	B	C	D	E	F	G	H	I	J	K	L	M	N	O	P	Q	R	S	T	U	V°	W
3/4"	072	1-1/4"	1-9/16"	7/8"	11/16"		3/16"	9/32"	3/16"	1/8"	7/16"	5/8"	1-1/4"	1-1/4"	7/8"	.240	1/8"	5/16"	10-24 x 1/2"	* 10-32	1/4-20 x 7/16	3/16"	14°	5/16"
1-1/8"	112	1-1/2"	1-7/8"	7/8"	1"		1/4"	9/32"	15/64"	1/8"	9/16"	3/4"	1-1/2"	1-1/2"	1-9/64"	.365	13/64"	1/2"	5/16-18 x 5/8"	1/8-27	1/4-20 x 7/16	3/16"	10°	1/4"
1-5/8"	162	2"	2-7/16"	1-1/8"	1-5/16"	SEE NOTE NUMBER 2 BELOW	1/4"	13/32"	9/32"	1/8"	3/4"	1"	2"	2"	1-9/16"	.490	5/16"	5/8"	3/8-16 x 5/8"	1/8-27	1/4-20 x 9/16	1/4"	8°	5/16"
2"	202	2-1/2"	2-11/16"	1-3/8"	1-5/16"		3/8"	7/16"	9/32"	1/4"	15/16"	1-1/4"	2-1/2"	2-1/2"	1-1/2"	.490	1/2"	5/8"	3/8-16 x 7/8"	1/8-27	5/16-18 x 11/16"	1/4"	14°	3/4"
2-1/2"	252	3"	3-1/4"	1-1/2"	1-3/4"		3/8"	1/2"	15/32"	1/4"	1-3/16"	1-1/2"	3"	3"	1-13/16"	.615	19/32"	3/4"	1/2-13 x 7/8"	1/8-27	3/8-16 x 3/4"	5/16"	11°	3/4"
3"	302	3-1/2"	3-1/2"	1-3/4"	1-3/4"		3/8"	9/16"	15/32"	1/4"	1-7/16"	2"	4"	3-1/2"	2-1/4"	.615	13/16"	3/4"	1/2-13 x 1-1/8"	** 1/8-27	3/8-16 x 7/8"	5/16"	9°	13/16"

\*1/8-27 Pipe Tap Optional

\*\*1/4-18 Pipe Tap Optional

Notes:	
#1	3/4" to 1-5/8" bore have ports 180° apart and 2 MTG holes. 2" bore and up have ports on same side and 4 MTG holes. Other porting, consult factory.
#2	See chart on page 11 for standard jaws lengths. Standard jaws are in a blank form to be modified. Specials welcome.
#3	Gripping force calculations on pages 4 & 5.

All Dimensions in Inches

# Angular Grippers: 2 Jaw

Base Mount Square Body Gripper "BG"

Base Mount Square Body Gripper with Double Rod "BDG"

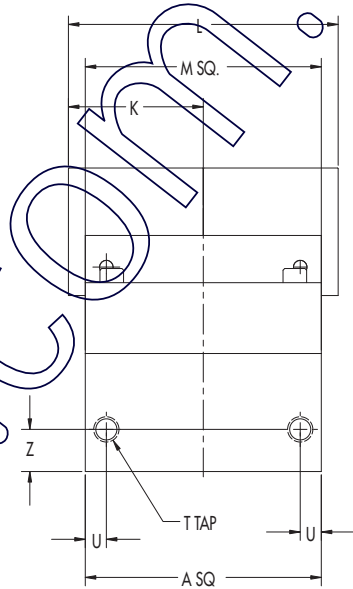
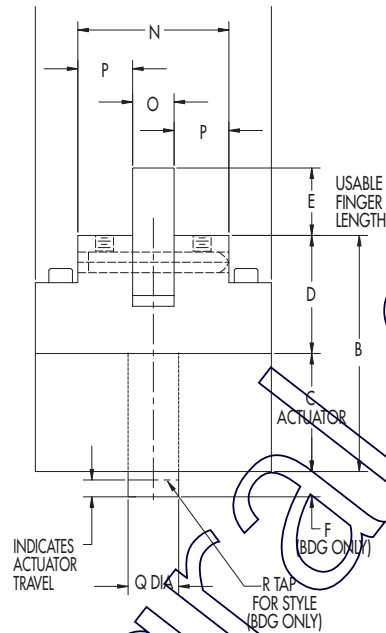
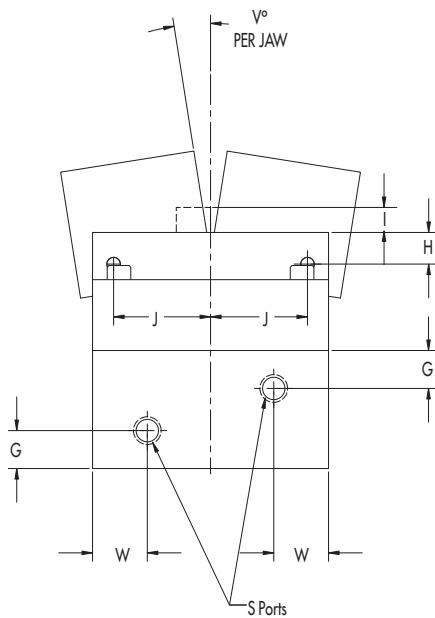

Bore	Part #	A	B	C	D	E	F	G	H	I	J	K	L	M	N	O	P	Q	R	S	T	U	V°	W	Z
3/4"	072	1-1/4"	1-9/16"	7/8"	11/16"		3/16"	9/32"	3/16"	1/8"	7/16"	5/8"	1-1/4"	1-1/4"	7/8"	.240	1/8"	5/16"	10-24 x 1/2"	* 10-32	10-24 x 1/4"	3/16"	14°	5/16"	3/8"
1-1/8"	112	1-1/2"	1-7/8"	7/8"	1"		1/4"	9/32"	15/64"	1/8"	9/16"	3/4"	1-1/2"	1-1/2"	1-9/64"	.365	13/64"	1/2"	5/16-18 x 5/8"	1/8-27	10-24 x 1/4"	3/16"	10°	1/4"	3/8"
1-5/8"	162	2"	2-7/16"	1-1/8"	1-5/16"	SEE NOTE NUMBER 2 BELOW	1/4"	13/32"	9/32"	1/8"	3/4"	1"	2"	2"	1-9/16"	.490	5/16"	5/8"	3/8-16 x 5/8"	1/8-27	1/4-20 x 5/16"	1/4"	8°	5/16"	1/2"
2"	202	2-1/2"	2-11/16"	1-3/8"	1-5/16"	SEE NOTE NUMBER 2 BELOW	3/8"	7/16"	9/32"	1/4"	15/16"	1-1/4"	2-1/2"	2-1/2"	1-1/2"	.490	1/2"	5/8"	3/8-16 x 7/8"	1/8-27	5/16-18 x 1/2"	1/4"	14°	3/4"	1/2"
2-1/2"	252	3"	3-1/4"	1-1/2"	1-3/4"	SEE NOTE NUMBER 2 BELOW	3/8"	1/2"	15/32"	1/4"	1-3/16"	1-1/2"	3"	3"	1-13/16"	.615	19/32"	3/4"	1/2-13 x 7/8"	1/8-27	5/16-18 x 5/8"	1/4"	11°	3/4"	1/2"
3"	302	3-1/2"	3-1/2"	1-3/4"	1-3/4"	SEE NOTE NUMBER 2 BELOW	3/8"	9/16"	15/32"	1/4"	1-7/16"	2"	4"	3-1/2"	2-1/4"	.615	13/16"	3/4"	1/2-13 x 1-1/8"	1/8-27	3/8-16 x 3/4"	5/16"	9°	13/16"	5/8"

\*1/8-27 Pipe Tap Optional

\*\*1/4-18 Pipe Tap Optional

### Notes:

#1	All ports located on same side, diagonal to each other. Other port locations available - Consult Factory.
#2	See chart on page 11 for standard jaw lengths. Standard jaws are in blank form to be modified. Specials welcome.
#3	Gripping force calculations on pages 4 & 5.

All Dimensions in Inches

# Angular Grippers: 3 Jaw

## Round Body Gripper "RG"

## Round Body Gripper with Double Rod "RDG"

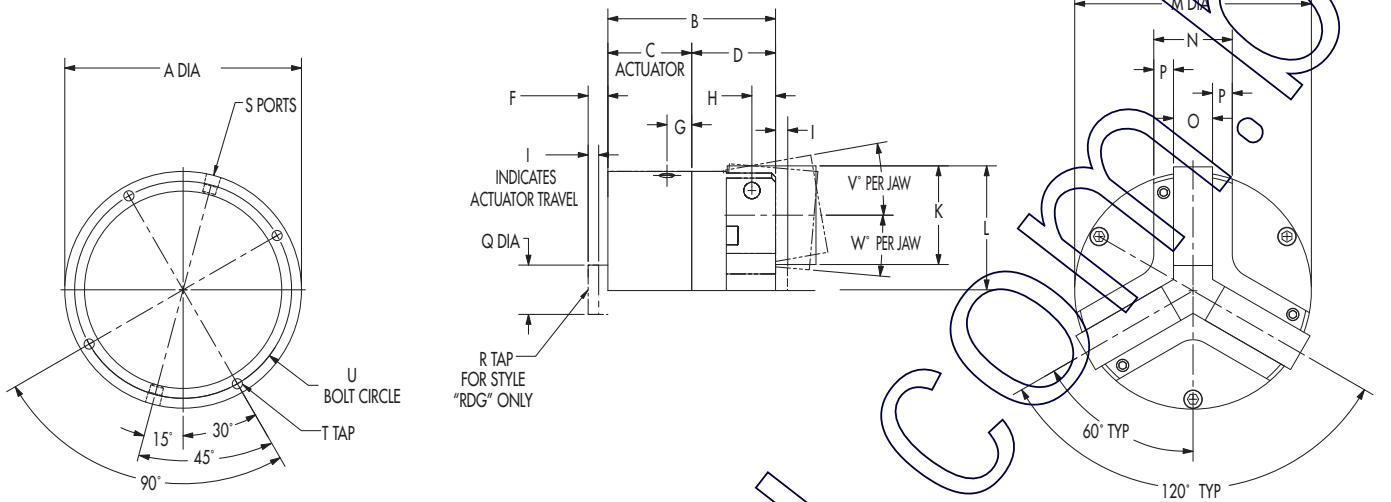

Specials Welcome — Materials, Custom Jaws, Jaw Opening, Etc.

Bore	Part #	A	B	C	D	E	F	G	H	I	J	K	L	M	N	O	P	Q	R	S	T	U	V°	W°
3/4"	073	1-1/2"	1-1/2"	13/16"	11/16"	SEE NOTE NUMBER 2-BELOW	1/8"	9/32"	3/16"	1-1/8"	31/64"	1/2"	43/64"	1-1/2"	3/4"	.240	1/4"	5/16"	10-24 x 1/4"	* 10-32	10-24 x 3/8"	1-1/8"	10°	2°
1-1/8"	113	1-7/8"	1-9/16"	7/8"	11/16"		1/4"	9/32"	3/16"	1/8"	37/64"	1/2"	49/64"	1-7/8"	3/4"	.240	1/4"	1/2"	5/16-18 x 5/16"	1/8-27	10-24 x 3/8"	1-1/2"	10°	2°
1-5/8"	163	2-3/8"	2-1/16"	1-1/8"	15/16"		1/4"	13/32"	1/4"	1/8"	57/64"	3/4"	1-5/64"	2-3/8"	1"	.365	5/16"	5/8"	3/8-16 x 7/16"	1/8-27	10-24 x 9/16"	2"	10°	2°
2-1/2"	253	3-1/2"	2-11/16"	1-1/2"	1-3/16"		5/8"	1/2"	5/16"	1/4"	1-21/64"	1-1/4"	1-41/64"	3-1/2"	1-1/4"	.490	3/8"	3/4"	1/2-13 x 5/8"	** 1/8-27	1/4-20 x 3/4"	3"	13°	2°
3"	303	4"	3"	1-3/4"	1-1/4"		3/8"	9/16"	5/16"	1/4"	1-21/64"	1-1/4"	1-41/64"	4"	1-1/2"	.490	1/2"	3/4"	1/2-13 x 5/8"	** 1/8-27	5/16-18 x 3/4"	3-1/2"	13°	2°
4"	403	5"	3-3/4"	2"	1-3/4"		1/2"	21/32"	1/2"	3/8"	1-61/64"	2"	2-33/64"	5"	2"	.615	11/16"	1"	1/2-13 x 3/4"	** 1/8-27	5/16-18 x 3/4"	4-1/2"	13°	2°
5"	503	6"	4-1/4"	2-1/8"	2-1/8"		1/2"	21/32"	5/8"	3/8"	2-33/64"	2-1/2"	3-9/64"	6"	2"	.990	1/2"	1-1/4"	1/2-13 x 1-3/4"	** 1/8-27	5/16-18 x 3/4"	5-1/2"	10°	2°
6"	603	7"	4-5/8"	2-1/2"	2-1/8"		5/8"	25/32"	5/8"	1/2"	3-1/64"	3"	3-41/64"	7"	2"	.990	1/2"	1-1/4"	1/2-13 x 1"	** 1/8-27	5/16-18 x 3/4"	6-1/2"	10°	2°
8"	803	9"	5-3/8"	3"	2-3/8"		7/8"	25/32"	13/16"	3/4"	3-33/64"	3-1/2"	4-17/64"	9"	3"	.990	1"	1-1/2"	1/2-13 x 1"	** 1/8-27	5/16-18 x 3/4"	8-1/2"	14°	2°

\*1/8-27 Pipe Tap Optional

\*\*1/4-18 Pipe Tap Optional

### Notes:

#1 All parts located on same side, diagonal to each other. Other port locations available - Consult Factory.

#2 See chart on page 11 for standard jaw lengths. Standard jaws are in blank form to be modified. Specials welcome.

#3 Gripping force calculations on pages 4 & 5.

All Dimensions in Inches

# Angular Grippers: 2 & 3 Jaw

## Com-Pick Pneumatic Grippers Blank Jaws — Standard Lengths

### 2 Jaw

Standard Blank Jaw Lengths				
Bore	Series	Standard Lengths		
1/2"	<b>052</b>	1/2"	1"	--
3/4"	<b>072</b>	1"	2"	3"
1-1/8"	<b>112</b>	1"	2"	3"
1-5/8"	<b>162</b>	1"	2"	3"
2"	<b>202</b>	1"	2"	3"
2-1/2"	<b>252</b>	1"	3"	5"
3"	<b>302</b>	1"	3"	5"
4"	<b>402</b>	1"	3"	5"
4"	<b>412</b>	1"	3"	5"
5"	<b>502</b>	1"	3"	5"
6"	<b>602</b>	1"	3"	5"
8"	<b>802</b>	1"	3"	5"

### 3 Jaw

Standard Blank Jaw Lengths				
Bore	Series	Standard Lengths		
3/4"	<b>073</b>	1"	2"	3"
1-1/8"	<b>113</b>	1"	2"	3"
1-5/8"	<b>163</b>	1"	2"	3"
2-1/2"	<b>253</b>	1"	2"	3"
3"	<b>303</b>	1"	3"	5"
4"	<b>403</b>	1"	3"	5"
5"	<b>503</b>	1"	3"	5"
6"	<b>603</b>	1"	3"	5"
8"	<b>803</b>	1"	3"	5"

### Option

Any Com-Pick gripper may be purchased with or without jaws. Pivot drawings are available to aid in the designing of your own tooling. Consult the factory or your local distributor.

### Tooling Only

To order a "set" of jaws only:

Specify: F  A

Series required      Length in Inches

### NOTES:

- Blank jaws are made of "1018" free machining steel.
- Other materials, lengths and configurations available - Consult factory or local distributor.

### Option "PA" Positive Alignment Pocket

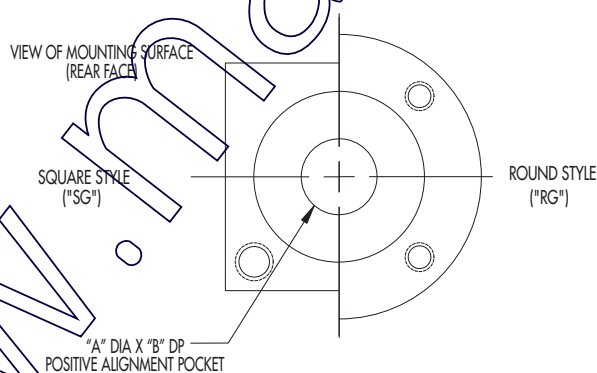

Bore	1/2"	3/4"	1-1/8"	1-5/8"	2"	2-1/2"	3"	4"	5"	6"	8"
"A"	.250	.312	.500	.625	.750	.750	1.500	1.500	1.500	1.500	1.500
"B"	1/16	1/8	1/8	3/16	1/4	1/4	5/16	5/16	5/16	5/16	5/16

### NOTES:

- "PA" Option not available on base style grippers. Consult factory for positive alignment mounting on base style. (BG/BDG)
- Not available on double rod end actuators.

All Dimensions in Inches

# Angular Grippers: 2 & 3 Jaw

## Com-Pick Pneumatic Grippers Pre-Modified "L" Jaw Option# "LJ"

Tooling Only

To order a "set" of jaws only:

Specify: F 112 ALJ

Series  
required

1/4" TAP THRU  
(2 PLACES PER FINGER)  
CLEARANCE FOR "J" SCREW

H DRILL THRU  
(1-5/8 BORE & UP)

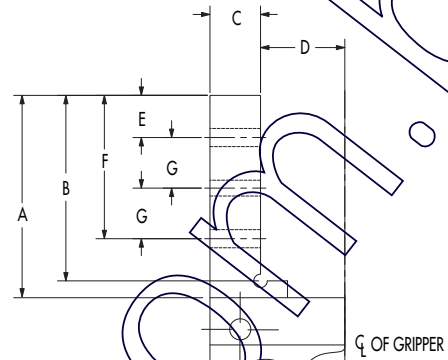
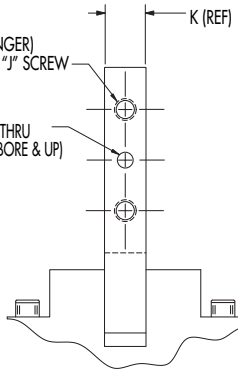

### Special Step Jaws for 2 & 3 Jaw Angular Grippers

#### 2 Jaw Grippers

Series	A	B	C	D	E	F	G	H	I	J	K*
052	1"	7/8"	1/4"	1/4"	1/4"	5/8"	N/A	N/A	#8-32	#5	1/4"
072	1"	7/8"	1/4"	3/8"	1/4"	5/8"	N/A	N/A	#8-32	#5	1/4"
112	1"	7/8"	3/8"	3/8"	1/4"	5/8"	N/A	N/A	#10-24	#6	3/8"
162	2"	1-3/4"	1/2"	1/2"	7/16"	1-5/16"	7/16"	#31 (.120)	1/4-20	#10	1/2"
202	2"	1-3/4"	1/2"	3/4"	7/16"	1-5/16"	7/16"	#31 (.120)	1/4-20	#10	1/2"
252	3"	2-3/4"	3/4"	3/4"	5/8"	2-1/8"	3/4"	15/64	5/16-18	1/4	5/8"
302	3"	2-3/4"	3/4"	1-1/4"	5/8"	2-1/8"	3/4"	15/64	5/16-18	1/4	5/8"
402	3"	2-3/4"	1"	1-1/2"	5/8"	2-1/8"	3/4"	15/64	5/16-18	1/4	1"
412/502	3"	2-3/4"	1"	2"	5/8"	2-1/8"	3/4"	15/64	5/16-18	1/4	1"
602	Consult factory.										
802											

#### 3 Jaw Grippers

Series	A	B	C	D	E	F	G	H	I	J	K*
073	1"	7/8"	1/4"	27/64"	1/4"	5/8"	N/A	N/A	8-32	#5	1/4"
113	1"	7/8"	1/4"	33/64"	1/4"	5/8"	N/A	N/A	8-32	#5	1/4"
163	1"	7/8"	3/8"	45/64"	1/4"	5/8"	N/A	N/A	10-24	#6	3/8"
253	2"	1-3/4"	1/2"	1-9/64"	7/16"	1-5/16"	7/16"	#31 (.120)	1/4-20	#10	1/2"
303	2"	1-3/4"	1/2"	1-9/64"	7/16"	1-5/16"	7/16"	#31 (.120)	1/4-20	#10	1/2"
403	3"	2-3/4"	3/4"	1-49/64"	5/8"	2-1/8"	3/4"	15/64	5/16-18	#1/4	5/8"
503	3"	2-3/4"	1"	2-9/64"	5/8"	2-1/8"	3/4"	15/64	5/16-18	#1/4	1"
603	Consult factory.										
803											

\*K dimension is ground .010 under fraction given.

All Dimensions in Inches



# Parallel Motion Grippers - Com-Pick II Pneumatic Grippers 2 Jaw

## Introduction

### True Parallel Motion Grippers & Accessories

**Com-Pick II** grippers are designed for use in industrial applications such as robotics, pick-n-place, automated assembly, and manipulator/tooling. All units feature a self-contained, double-acting actuator. "Generic" grippers can be mounted to any manufacturer's robot, manipulator or actuator by way of an adapter flange. Low unit weight, high output and compact size are features of all models. Special materials, tooling, and adapter flanges are available upon request.

Seal options, jaw options, sensor options, etc., can be easily added at assembly for prompt delivery of all variations.

Parallel motion grippers represent a highly versatile and flexible design. The integral pneumatic cylinder pushes the jaws open. The jaws slide along two hardened guide rods providing rigid, long lasting true parallel motion. The pull stroke closes the jaws. A four-way valve circuit is required for control.

All units are of two jaw design.

Gripping forces, formulas, unit weights, and dimensions are included in the following sections.

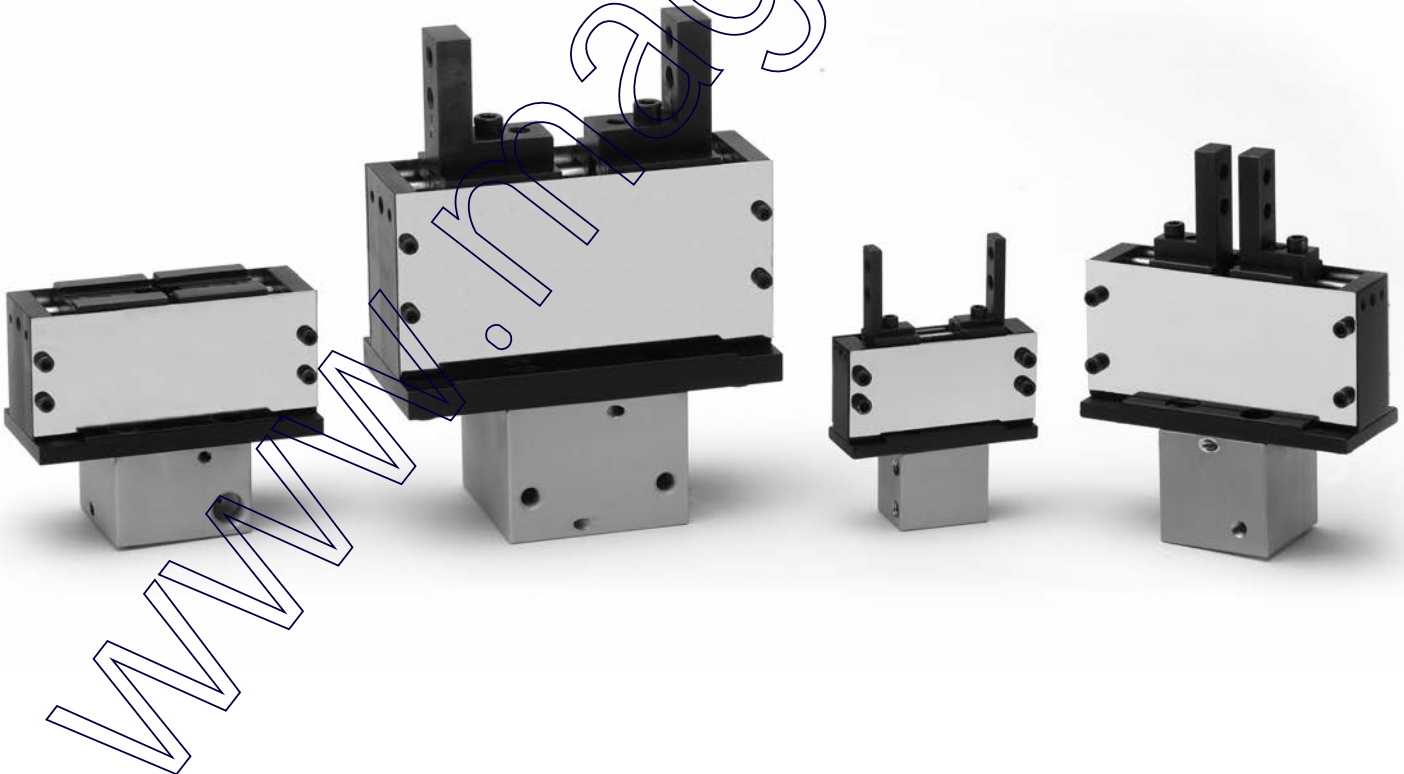



# Parallel Motion Grippers - Com-Pick II Pneumatic Grippers 2 Jaw

## Engineering Data

### Self Contained Actuator

Cylinders feature low profiles, low weight aluminum alloy bodies, and stainless steel piston rods. All units are prelubricated for life.

### Actuator Seals

As standard, actuators are packed with seals of Buna-N rubber. Temperature limits are from 0°F to 200°F (-18°C to 90°C). All actuators are prelubricated at the factory and do not require additional lubrication.

Seal options — page 24.

### Materials

Actuators are aluminum alloy with bronze rod bushings. All sliding parts are heat treated steel for long, trouble-free operation. Mechanism cover pieces are stamped stainless steel.

### Tooling



Com-Pick II grippers are "generic" in standard form. Base jaws are slotted and tapped for tooling. Pre-modified "L" jaws are available or you can add your own V-blocks, pads, sensors, etc. Also, see page 18.

## Pressure Ratings

<b>Pneumatic</b>	Clean, dry or lubricated — 15 PSI to 200 PSI (125 PSI In 052 series)
<b>Hydraulic</b>	Consult factory

## Pre-Calculated Gripping Forces

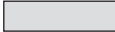
Gripper		Air Pressure (PSI)				
Series	Bore	20 PSI	40 PSI	60 PSI	80 PSI	100 PSI
<b>052</b>	1/2"	2 LBS.	4 LBS.	6 LBS.	8 LBS.	10 LBS.
		1.5 LBS.	3 LBS.	4.5 LBS.	6 LBS.	7.5 LBS.
<b>072</b>	3/4"	4.4 LBS.	8.8 LBS.	13.2 LBS.	17.6 LBS.	22 LBS.
		3.6 LBS.	7.2 LBS.	10.8 LBS.	14.4 LBS.	18 LBS.
<b>112</b>	1-1/8"	10 LBS.	20 LBS.	30 LBS.	40 LBS.	50 LBS.
		8 LBS.	16 LBS.	24 LBS.	32 LBS.	40 LBS.
<b>132</b>	1-3/8"	15 LBS.	30 LBS.	45 LBS.	60 LBS.	75 LBS.
		12 LBS.	24 LBS.	36 LBS.	48 LBS.	60 LBS.
<b>162</b>	1-5/8"	20 LBS.	40 LBS.	60 LBS.	80 LBS.	100 LBS.
		17 LBS.	34 LBS.	51 LBS.	68 LBS.	85 LBS.
<b>202</b>	2"	30 LBS.	60 LBS.	90 LBS.	120 LBS.	150 LBS.
		27 LBS.	54 LBS.	81 LBS.	108 LBS.	135 LBS.

-  — Open — I.D. Gripping
-  — Closed — O.D. Gripping

### ★ Important Notes ★

- Gripping forces are theoretical and will vary due to friction. 7% to 10% force reduction per inch of tooling length is approximate force loss.
- Long, heavy tooling decreases performance of the gripper and should be avoided.

Maximum recommended tooling length:

- Series 052, 072 and 112 = 2"
- Series 132, 162 and 202 = 5"

# Parallel Motion Grippers - Com-Pick II Pneumatic Grippers 2 Jaw

## Engineering Data Continued

### Estimated Unit Weights Without Tooling (Lbs)

Series	052	072	112	132	162	202
Short Travel	.21	.60	.95	2.05	2.20	2.65
Long Travel	.25	.70	1.10	2.30	2.45	2.95

### Theoretical Gripping Force Formulas

NOTE: Gripping forces are constant at any point of jaw travel. Due to friction caused by leverage, 7% to 10% force loss per inch of tooling length should be considered. Long jaw tooling will reduce the life of the gripper and is not recommended. Consult factory.

$$\text{Gripping Force} = \frac{\text{PSI} \times \text{Piston Area}}{2}$$

BORE	SERIES	1/2"	3/4"	1-1/8"	1-3/8"	1-5/8"	2"
		052	072	112	132	162	202
IN. <sup>2</sup>	Push (Open)	.2	.44	1.0	1.5	2	3
IN. <sup>2</sup>	Pull (Close)	.15	.36	.8	1.2	1.7	2.7

### Double Rod End Actuators

Unlike the angular type grippers, Double Rod End Actuators are not standard for Parallel Grippers due to the extra length the double ended rod adds in the longer strokes required for parallel gripping. Double Rod End Actuators can be special ordered. Primary application for this option is limit sensing with mechanical switches. See pages 21-23 for sensors.

# Parallel Grippers: 2 Jaw

## Square Body Grippers "PSG" (End/Rear Face Mounted)

**Important Note:** Unit mounting holes are ONLY difference between styles "PSG" & "PBG"

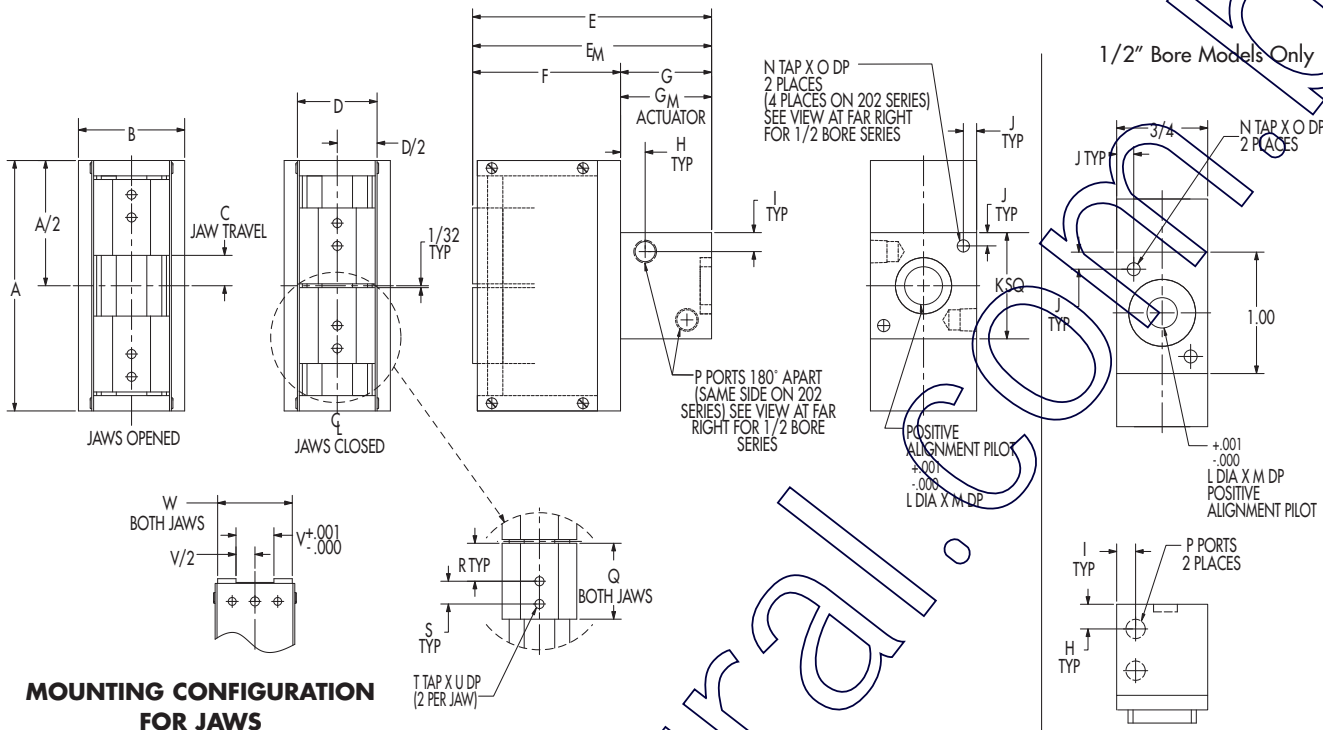

Bore	Gripper	Part #	A	B	C	D	E	**E <sub>M</sub>	F	G	**G <sub>M</sub>	H	I	J	K	L
1/2"	Square 1/2 Bore x 1/8 Jaw Travel	PSG052 x 1/8	1-7/8	3/4	1/8	9/16	1-3/4	2.0	1.0	3/4	1.0	13/64	5/32	9/64	1.0	.250
	Square 1/2 Bore x 1/4 Jaw Travel	PSG052 x 1/4	2-1/8	3/4	1/4	9/16	2-1/8	2-3/8	1-1/4	7/8	1-1/8	13/64	5/32	9/64	1.0	.250
3/4"	Square 3/4 Bore x 1/4 Jaw Travel	PSG072 x 1/4	2-5/8	1-1/4	1/4	13/16	2-3/8	2-5/8	1-3/8	1.0	1-1/4	9/32	5/16	3/16	1-1/4	.312
	Square 3/4 Bore x 1/2 Jaw Travel	PSG072 x 1/2	3-1/8	1-1/4	1/2	13/16	3.0	3-1/4	1-3/4	1-1/4	1-1/2	9/32	5/16	3/16	1-1/4	.312
1-1/8"	Square 1-1/8 Bore x 1/4 Jaw Travel	PSG112 x 1/4	3-1/8	1-1/2	1/4	1-1/16	2-5/8	2-7/8	1-5/8	1.0	1-1/4	9/32	1/4	3/16	1-1/2	.500
	Square 1-1/8 Bore x 1/2 Jaw Travel	PSG112 x 1/2	3-5/8	1-1/2	1/2	1-1/16	3-1/4	3-1/2	2.0	1-1/4	1-1/2	9/32	1/4	3/16	1-1/2	.500
1-3/8"	Square 1-3/8 Bore x 1/2 Jaw Travel	PSG132 x 1/2	4-1/8	1-3/4	1/2	1-5/16	3-15/16	4-3/16	2-7/16	1-1/2	1-3/4	13/32	5/16	7/32	1-3/4	.625
	Square 1-3/8 Bore x 3/4 Jaw Travel	PSG132 x 3/4	4-5/8	1-3/4	3/4	1-5/16	4-9/16	4-13/16	2-13/16	1-3/4	2.0	13/32	5/16	7/32	1-3/4	.625
1-5/8"	Square 1-5/8 Bore x 1/2 Jaw Travel	PSG162 x 1/2	4-1/8	2.0	1/2	1-5/16	3-15/16	4-3/16	2-7/16	1-1/2	1-3/4	13/32	5/16	1/4	2.0	.625
	Square 1-5/8 Bore x 3/4 Jaw Travel	PSG162 x 3/4	4-5/8	2.0	3/4	1-5/16	4-9/16	4-13/16	2-13/16	1-3/4	2.0	13/32	5/16	1/4	2.0	.625
2"	Square 2.0 Bore x 1/2 Jaw Travel	PSG202 x 1/2	4-1/8	2-1/2	1/2	1-5/16	4-1/16	4-5/16	2-7/16	1-5/8	1-7/8	7/16	3/4	1/4	2-1/2	.750
	Square 2.0 Bore x 3/4 Jaw Travel	PSG202 x 3/4	4-5/8	2-1/2	3/4	1-5/16	4-11/16	4-15/16	2-13/16	1-7/8	2-1/8	7/16	3/4	1/4	2-1/2	.750

Bore	Part #	M	N	O	P	Q	R	S	T	U	V	W
1/2"	PSG052 x 1/8	1/16	#6-32	5/16	#10-32	1/2	1/4	5/32	#4-40	7/32	.250	.480
	PSG052 x 1/4	1/16	#6-32	3/8	#10-32	1/2	1/4	5/32	#4-40	7/32	.250	.480
3/4"	PSG072 x 1/4	1/8	#1/4-20	1/2	#10-32*	3/4	3/8	1/4	#6-32	3/16	.375	.730
	PSG072 x 1/2	1/8	#1/4-20	1/2	#10-32*	3/4	3/8	1/4	#6-32	3/16	.375	.730
1-1/8"	PSG112 x 1/4	1/8	#1/4-20	1/2	#1/8-27	1.0	1/2	5/16	#6-32	1/4	.500	.980
	PSG112 x 1/2	1/8	#1/4-20	1/2	#1/8-27	1.0	1/2	5/16	#6-32	1/4	.500	.980
1-3/8"	PSG132 x 1/2	3/16	#1/4-20	1/2	#1/8-27	1-1/4	5/8	3/8	#10-24	3/8	.625	1.230
	PSG132 x 3/4	3/16	#1/4-20	1/2	#1/8-27	1-1/4	5/8	3/8	#10-24	3/8	.625	1.230
1-5/8"	PSG162 x 1/2	3/16	#1/4-20	1/2	#1/8-27	1-1/4	5/8	3/8	#10-24	3/8	.625	1.230
	PSG162 x 3/4	3/16	#1/4-20	1/2	#1/8-27	1-1/4	5/8	3/8	#10-24	3/8	.625	1.230
2"	PSG202 x 1/2	1/4	#5/16-18	5/8	#1/8-27	1-1/4	5/8	3/8	#10-24	3/8	.625	1.230
	PSG202 x 3/4	1/4	#5/16-18	5/8	#1/8-27	1-1/4	5/8	3/8	#10-24	3/8	.625	1.230

\* 1/8-27 Pipe Tap, Optional  
 \*\* For magnetic piston, specify prefix "A". Refer to page 21 for track locations and see pages 22-23 for additional sensor information.

See Notes on page 18.

All Dimensions in Inches



# Parallel Grippers: 2 Jaw

## Base Mounted Gripper "PBG" (Square Body With Base Mounting Holes)

**Important Note:** Unit mounting holes are ONLY difference between styles "PBG" & "PSG"

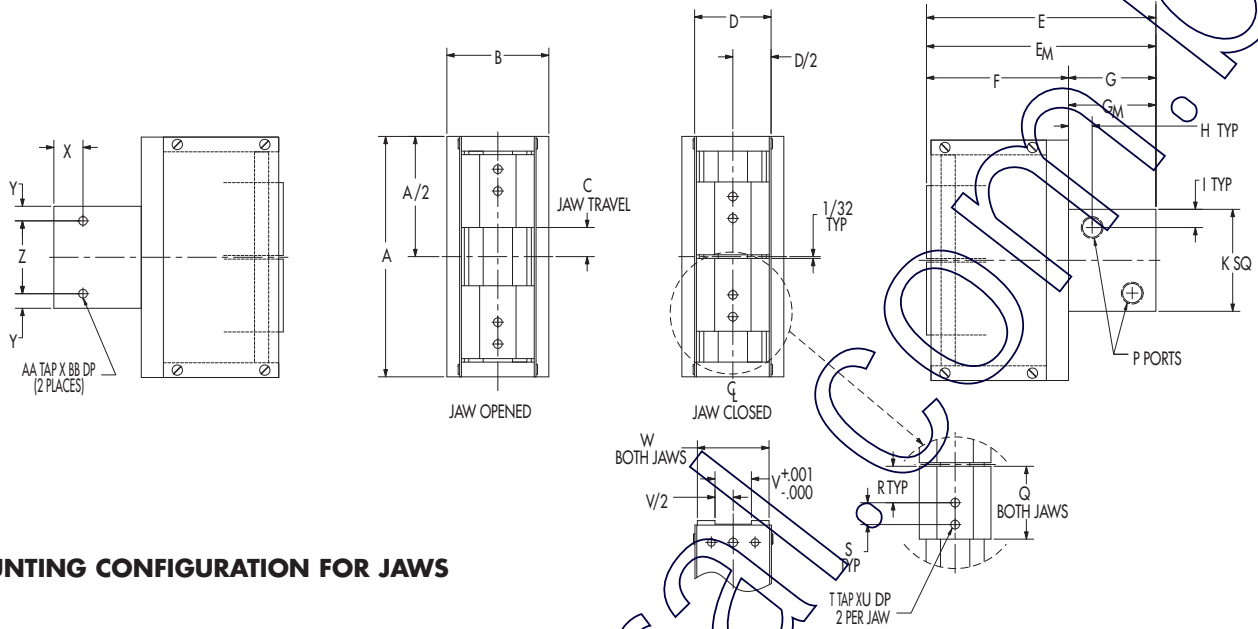

### MOUNTING CONFIGURATION FOR JAWS

Bore	Gripper	Part #	A	B	C	D	E	**E <sub>M</sub>	F	G	**G <sub>M</sub>	H	I	K
3/4"	Square 3/4 Bore x 1/4 Jaw Travel	PBG072 x 1/4	2-5/8	1-1/4	1/4	13/16	2-3/8	2-5/8	1-3/8	1.0	1-1/4	9/32	5/16	1-1/4
	Square 3/4 Bore x 1/2 Jaw Travel	PBG072 x 1/2	3-1/8	1-1/4	1/2	13/16	3.0	3-1/4	1-3/4	1-1/4	1-1/2	9/32	5/16	1-1/4
1-1/8"	Square 1-1/8 Bore x 1/4 Jaw Travel	PBG112 x 1/4	3-1/8	1-1/2	1/4	1-1/16	2-5/8	2-7/8	1-5/8	1.0	1-1/4	9/32	1/4	1-1/2
	Square 1-1/8 Bore x 1/2 Jaw Travel	PBG112 x 1/2	3-5/8	1-1/2	1/2	1-1/16	3-1/4	3-1/2	2.0	1-1/4	1-1/2	9/32	1/4	1-1/2
1-3/8"	Square 1-3/8 Bore x 1/2 Jaw Travel	PBG132 x 1/2	4-1/8	1-3/4	1/2	1-5/16	3-15/16	4-3/16	2-7/16	1-1/2	1-3/4	13/32	5/16	1-3/4
	Square 1-3/8 Bore x 3/4 Jaw Travel	PBG132 x 3/4	4-5/8	1-3/4	3/4	1-5/16	4-9/16	4-13/16	2-13/16	1-3/4	2.0	13/32	5/16	1-3/4
1-5/8"	Square 1-5/8 Bore x 1/2 Jaw Travel	PBG162 x 1/2	4-1/8	2.0	1/2	1-5/16	3-15/16	4-3/16	2-7/16	1-1/2	1-3/4	13/32	5/16	2.0
	Square 1-5/8 Bore x 3/4 Jaw Travel	PBG162 x 3/4	4-5/8	2.0	3/4	1-5/16	4-9/16	4-13/16	2-13/16	1-3/4	2.0	13/32	5/16	2.0
2"	Square 2.0 Bore x 1/2 Jaw Travel	PBG202 x 1/2	4-1/8	2-1/2	1/2	1-5/16	4-1/16	4-5/16	2-7/16	1-5/8	1-7/8	7/16	3/4	2-1/2
	Square 2.0 Bore x 3/4 Jaw Travel	PBG202 x 3/4	4-5/8	2-1/2	3/4	1-5/16	4-11/16	4-15/16	2-13/16	1-7/8	2-1/8	7/16	3/4	2-1/2

Bore	Part #	P	Q	R	S	T	U	V	W	X	Y	Z	AA	BB
3/4"	PBG072 x 1/4	#10-32*	3/4	3/8	1/4	#6-32	3/16	.375	.730	3/8	3/16	7/8	#10-24	5/16
	PBG072 x 1/2	#10-32*	3/4	3/8	1/4	#6-32	3/16	.375	.730	3/8	3/16	7/8	#10-24	5/16
1-1/8"	PBG112 x 1/4	#1/8-27	1.0	1/2	5/16	#6-32	1/4	.500	.980	3/8	3/16	1-1/8	#10-24	5/16
	PBG112 x 1/2	#1/8-27	1.0	1/2	5/16	#6-32	1/4	.500	.980	3/8	3/16	1-1/8	#10-24	5/16
1-3/8"	PBG132 x 1/2	#1/8-27	1-1/4	5/8	3/8	#10-24	3/8	.625	1.230	1/2	1/4	1-1/4	#10-24	5/16
	PBG132 x 3/4	#1/8-27	1-1/4	5/8	3/8	#10-24	3/8	.625	1.230	1/2	1/4	1-1/4	#10-24	5/16
1-5/8"	PBG162 x 1/2	#1/8-27	1-1/4	5/8	3/8	#10-24	3/8	.625	1.230	1/2	1/4	1-1/2	#1/4-20	3/8
	PBG162 x 3/4	#1/8-27	1-1/4	5/8	3/8	#10-24	3/8	.625	1.230	1/2	1/4	1-1/2	#1/4-20	3/8
2"	PBG202 x 1/2	#1/8-27	1-1/4	5/8	3/8	#10-24	3/8	.625	1.230	1/2	1/4	2.0	#5/16-18	1/2
	PBG202 x 3/4	#1/8-27	1-1/4	5/8	3/8	#10-24	3/8	.625	1.230	1/2	1/4	2.0	#5/16-18	1/2

\* 1/8-27 Pipe Tap, Optional  
 \*\* For magnetic piston, specify prefix "A". Refer to page 21 for track locations and see pages 22-23 for additional sensor information.

### Notes:

#1	Positive alignment mounting available on "B" Style Grippers. Consult factory.
#2	See page 20 for adjustable Jaw movement option.
#3	See page 19 for standard Jaws.
#4	Gripping force and unit weights on pages 15-16

All Dimensions in Inches

# Parallel Grippers: 2 Jaw

## Com-Pick II Pneumatic Grippers

**Jaw Options:** Jaw inserts below can be mounted to Master Jaws on gripper using 1 screw. By turning and positioning, each jaw can be attached in numerous variations.

### "L" Shaped Jaw Option "LF"

Tooling Only

To order a "set" of jaws only:

Specify: F 112 PLF

Series  
required

See Ordering Instructions to order attached to gripper

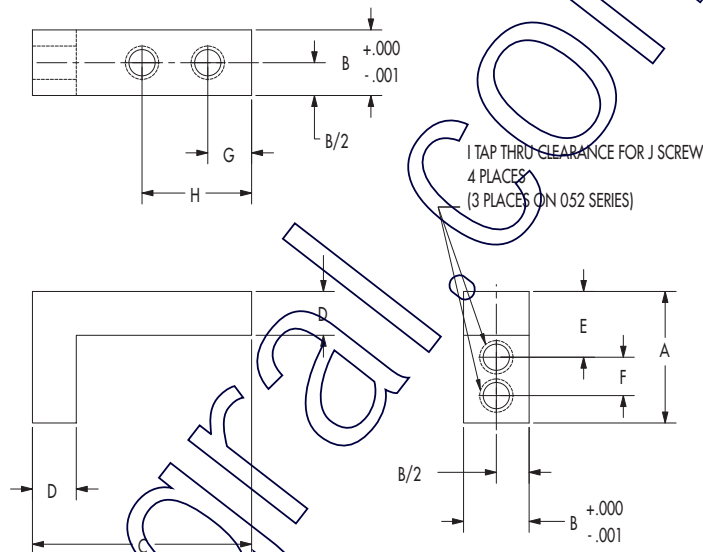

Gripper Series	Bore (Ref.)	A	B	C	D	E	F	G	H	I	J
052	1/2"	1/2	.249	1.0	1/8	1/4	-	3/16	1/2	#8-32	#4
072	3/4"	3/4	.374	1-1/4	1/4	3/8	7/32	1/4	5/8	#10-24	#6
112	1-1/8"	1.0	.499	1-1/4	1/4	1/2	9/32	1/4	5/8	#10-24	#6
132	1-3/8"	1-1/4	.624	1-1/2	3/8	5/8	11/32	1/4	11/16	#1/4-20	#10
162	1-5/8"										
202	2"										

#### Notes:

#1	Several mounting options for different open and closed position.
#2	Jaws made of 1018" Steel.
#3	Mounting screws are provided.

All Dimensions in Inches

# Options and Accessories

## Com-Pick and Comp-Pick II

### Adjustable Jaw Travel - Parallel Grippers Option "ADJO" / "ADJC"

Bore	Gripper Series	A	B	C	D	E	F
1/2"	PG052 x 1/8	15/32	3/8	10-32	4-40	.29	5/16
	PG052 x 1/4	15/32	1/2	10-32	4-40	.29	7/16
3/4"	PG072 x 1/4	9/16	11/16	1/4-20	6-32	.36	7/16
	PG072 x 1/2	9/16	15/16	1/4-20	6-32	.36	11/16
1-1/8"	PG112 x 1/4	3/4	13/16	3/8-16	8-32	.36	7/16
	PG112 x 1/2	3/4	1-1/16	3/8-16	8-32	.36	11/16
1-3/8"	PG132 x 1/2	3/4	1-1/16	3/8-16	10-24	.43	3/4
	PG132 x 3/4	3/4	1-5/16	3/8-16	10-24	.43	1
1-5/8"	PG162 x 1/2	3/4	1-1/16	3/8-16	10-24	.43	3/4
	PG162 x 3/4	3/4	1-5/16	3/8-16	10-24	.43	1
2"	PG202 x 1/2	1	1-1/4	1/2-13	10-24	.43	3/4
	PG202 x 3/4	1	1-1/2	1/2-13	10-24	.43	1

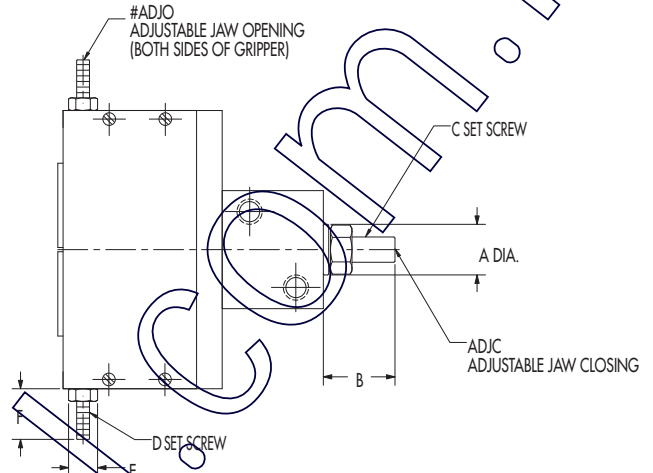

#### Notes:

#1	ADJC consists of Set Screw, Locking Nut, and Thread Seal. (Max. 200°F)
#2	ADJO consists of 2 Set Screws and 2 Locking Nuts.
#3	"PA" option not available on ADJC option.

### Adjustable Jaw Travel - Angular Grippers Option ADJ (Closed Adjustment Only)

#### Adjustment of Jaw Closure on 2 & 3 Jaw Angular Grippers

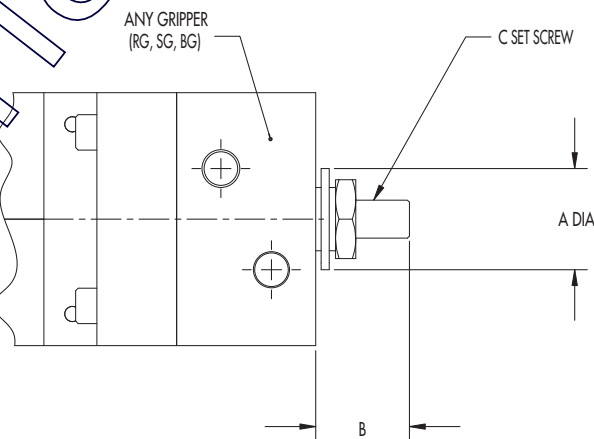

Series	052	072/073	112/113	162/163	202	252/253	302/303	402/412/403	502/503	602/603	802/803
Bore	1/2	3/4	1-1/8	1-5/8	2	2-1/2	3	4	5	6	8
A	15/32	9/16	3/4	3/4	1	1	1-3/8	1-3/8	1-3/8	1-3/8	1-3/8
B	3/8	9/16	11/16	11/16	15/16	15/16	1-1/4	1-3/8	1-3/8	1-1/2	1-3/4
C	10-32	1/4-28	3/8-24	3/8-24	1/2-13	1/2-13	3/4-10	3/4-10	3/4-10	3/4-10	3/4-10

#### Notes:

#1	Adjustment consists of Set Screw, Locking Nut, and Thread Seal. (Max. 200°F)
#2	Adjustment for Jaw closing only.
#3	"PA" option not available with ADJ option.

Dimensions typical for RG, SG, & BG style angular grippers.

# Options and Accessories

## Sensor Track Locations for Magnetic Piston Grippers

Diagrams illustrate rear of gripper actuator

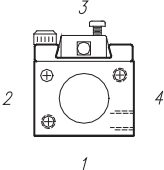
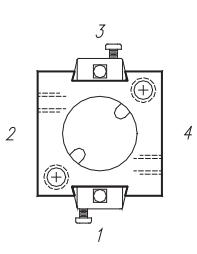
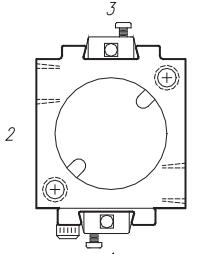
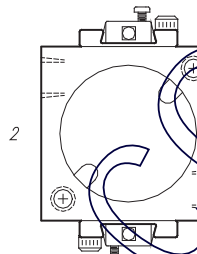
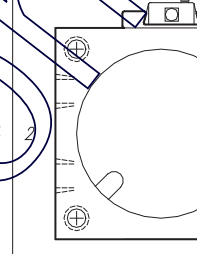
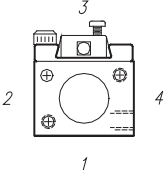
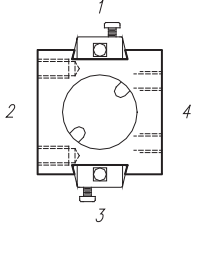
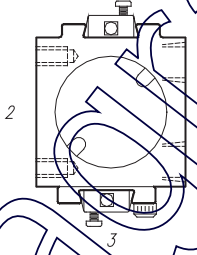
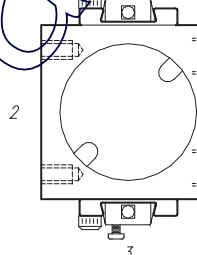
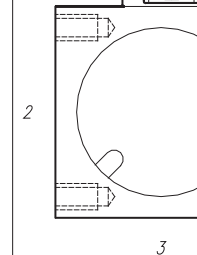
	1/2"	3/4"	1-1/8"	1-3/8" - 1-5/8"	2" - 3"
<b>Style "S" End Mount</b>	Design accommodates one sensor only 			♦ Parallel grippers with 3/4" jaw travel have one sensor mounting track  ♦ Omit track on side 1	
<b>Style "B" Base Mount</b>				 ♦ Omit track on side 3	

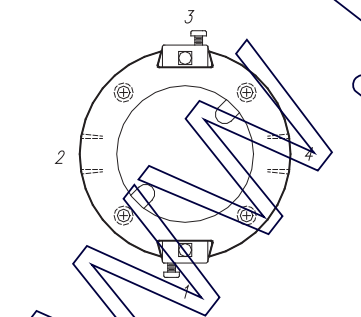
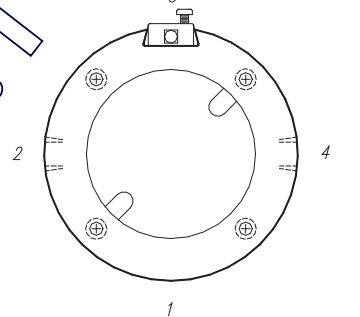
	3/4" - 1-5/8"	2" - 5"
<b>Style "R" End Mount</b>		

### Dimensional Information

#### Angular Gripper

1/2" - See page 6

3/4" thru 8" - Prefix "A" adds 1/4" to the overall actuator length

#### Parallel Gripper

Pre-calculated on dimensional pages

16-17

NOTE: The magnetic option is designed for sensing jaws "fully open" and "fully closed" only, not for indication of part. Reliable limit sensing may be adversely affected by minimal stroke grippers when sensing both open and close positions.

Consult factory for 6" and 8" bore sensor track locations.

# Sensors

## Standard Limit Sensors

- Low Cost and compact size
- Dual LED indicators for power and signal
- Circuit protection for surge and polarity
- High-flex robotic grade cable with 4,8mm (3/16") bend radius. 105 strand primaries.
- CE compliant / IP67 and NEMA 6P rated
- 100% solid state device for maximum life
- 3 cord options

(Shown with Quick Disconnect Option)



### 3 Prong Plug

#WSKLP, #WSCLP, #WSKLPS, #WSCLPS

WS\_LP

WS\_LPS

Part No.	Sensor Type (Wiring diagrams and definitions on page 23)	Cord Types		
		Quick Disconnect	1 Meter	3 Meter
Sinking	NPN		✓	
		✓*		
				✓
		✓*		
Sourcing	PNP			
		✓*		
				✓
		✓*		

\*NOTE: Mating 3 socket receptacle available, part # R3

## Optional Quick Disconnect Sensor Cable with threaded, sealed connectors

Part Number - Specify **K** or **C**

### Plug - 3 Prong

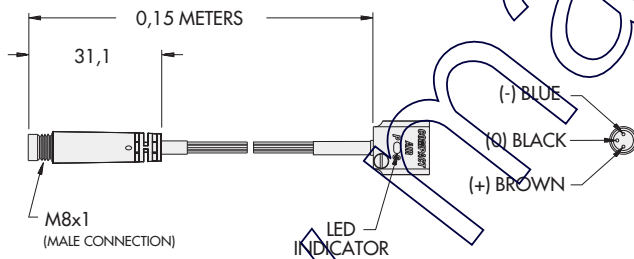

**3 Socket Mating Cable**  
For use with:  
#WSKLP, #WSCLP, #WSKLPS, #WSCLPS,

**Sold Separately**

**Part Number**  
R3

### Receptacle - 3 Socket

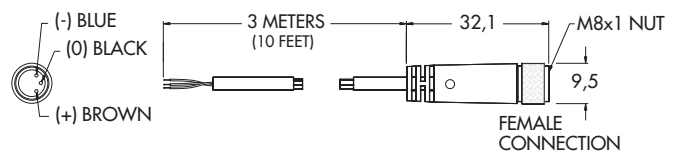



# Sensors

## Comtronic® Sensors Dimensional Information

Must specify 'K' (sinking) or 'C' (sourcing) when ordering

Part Number - Specify K or C

**WS\_L      WS\_L-3**

"3" denotes 3 meter cable

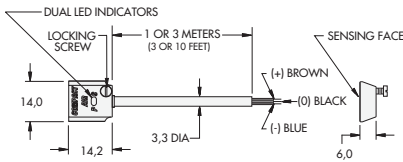

Part No. **WSKL-3** - Sinking output with 3 meter cable.



Specifications		
Parameters	Comtronic® Standard Limit Sensors	
	NPN (sinking)	PNP (sourcing)
Part Number	WSKL, WSKL3, WSKLP, WSKLPS	WSCL, WSCL3, WSCLP, WSCLPS
Operating Voltage	5-24 VDC	
Current Consumption	16mA (at 24V) 7mA (at 24V)	14mA (at 24V) 7mA (at 24V)
Switching Current	100mA Max	
Voltage Drop	1.5 V Max @ 100mA	
Operating Frequency	1 KHz Max	
Switch Logic	Sinking, Normally Open	Sourcing, Normally Open
LED Function	Green      Power On Red        Switch Active (Magnet Present)	
Operating Temperature	0°C to 70°C	
Circuit Protection	Reverse Polarity / Surge Absorber	
Environmental Certifications	IEC standard IP67, NEMA 6P	
Wire Type	High flex, 24 AWG / 105 strand primary	
Housing Material	Zinc diecast	
Housing Color Code	Black	Silver
Shock Resistance	30G Max	
Vibration Strength	9G Max	

## Wiring Diagrams and Definitions

For units with flying leads

### NPN Output Sinking (K)

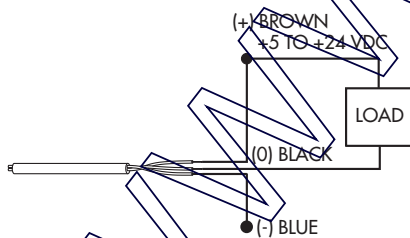

- Ideal for complex controls utilizing multiple power supplies.

A "sinking" output sensor complete a circuit by connecting the load to ground. Sinking output sensors in a sequence can have different supply voltages. The ground is their common factor.

### PNP Output Sourcing (C)

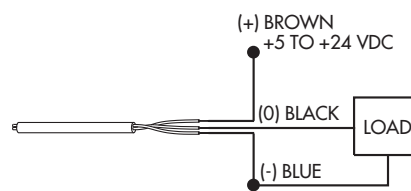

- Ideal for single power supply applications.

A "sourcing" output sensor completes a circuit by connecting the load to the supply current. All sourcing output sensors must have the same supply voltage.

# Options and Accessories

## Com-Pick and Com-Pick II 2 & 3 Jaw Pneumatic Grippers

### Actuator Seal Options

Seal Type	Standard	Option	Code	(PSI) Pressure	°F Temperature Range
<b>BUNA-N</b>	✓		--	2-200 PSI	0°F TO 200°F
<b>** Hi Temp. Viton</b>		✓	HTV	10-200 PSI	0°F TO 400°F
<b>**Corrosion Resistant Teflon</b>		✓	CRT*	10-200 PSI	200°F TO 500°F

\* Not available on parallel grippers and 1/2" bore models.

\*\* Due to metal expansion in elevated temperatures, our Jaw fit may have to be re-ground to compensate. Consult factory regarding other seal compounds or applications using media other than compressed air.

## Application Ideas

### Specials Welcome

For Engineering or Technical Assistance Consult Factory.

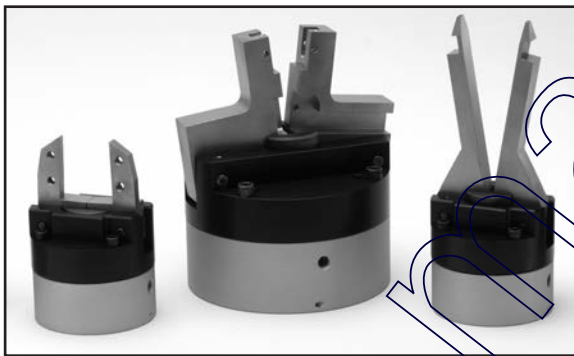

Typical Modifications to Blank Jaws

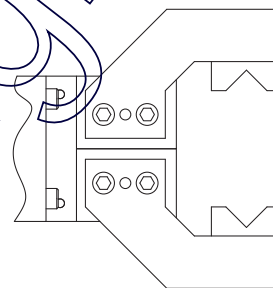

**Bolt-on tooling**

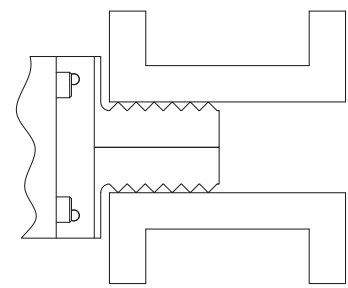

**I.D. Gripping**

- Textile applications
- Bulk wire handling

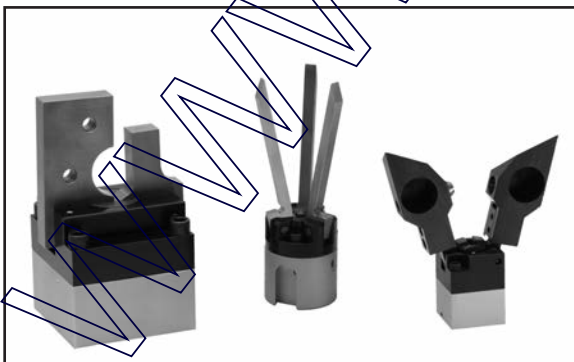

Special Tooling Modifications

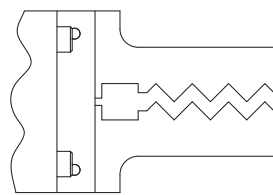

**"Spru-pickers" for Plastic Molds**

- Serrated and carburized jaws

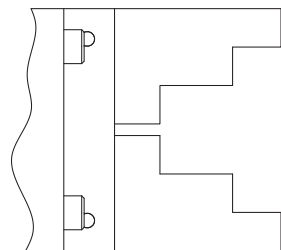

**Stepped Jaws**

- Benchtop workholding
- Multi-sized parts handling

[www.magraal.com.br](http://www.magraal.com.br)

[www.magraal.com.br](http://www.magraal.com.br)

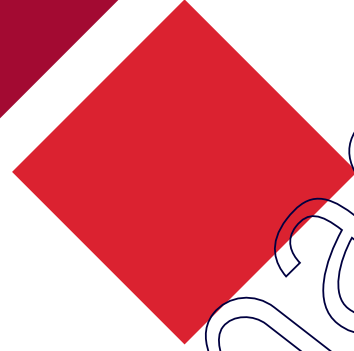
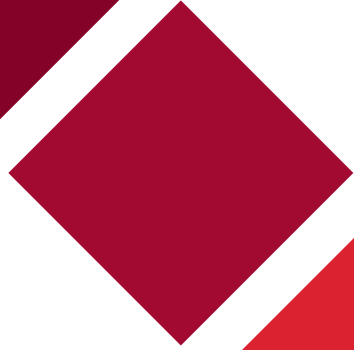

**COMPACT**<sup>®</sup>  
**AUTOMATION PRODUCTS**

Compact Automation Products, LLC  
105 Commerce Way  
Westminster, SC 29693  
Tel: 864.647.9521  
Fax: 864.647.9524  
[www.compactautomation.com](http://www.compactautomation.com)

CAP551R3

*An ITT Company*

11/20

[www.magral.com.br](http://www.magral.com.br)