

COMPACT[®]
AUTOMATION PRODUCTS

Guided Cylinder Products

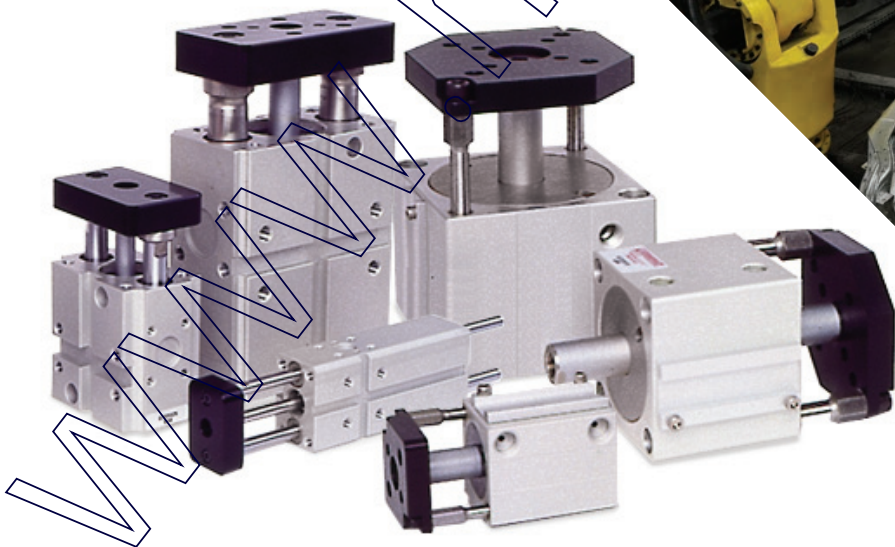

Table of Contents: Guided Cylinders

GC 2000, 3000 & 4000 Series

GC 2000 Series (Inch Base)

Introduction	pg. 2
How to Order	pg. 3
Dimensions	
Cylinders.....	pg. 4-7
Tooling Plates.....	pg. 8
Accessories.....	pg. 9-11
Engineering Data.....	pg. 12
Pilots & Other Options	pg. 13

GC 3000 / GC 4000 Series (Metric Base)

Introduction	pg. 14
How to Order.....	pg. 15
Design Features	pg. 16
Dimensions	
Cylinders.....	pg. 17-20
Accessories.....	pg. 21-22
Tooling Plates.....	pg. 23
Accessories, Unit Weights and Recommendations.....	pg. 24
Load Capacities.....	pg. 25-26
Moment Ratings.....	pg. 26
Application Examples.....	pg. 27-28
Sensors	pg. 29-32

3-D Models available online at www.compactautomation.com

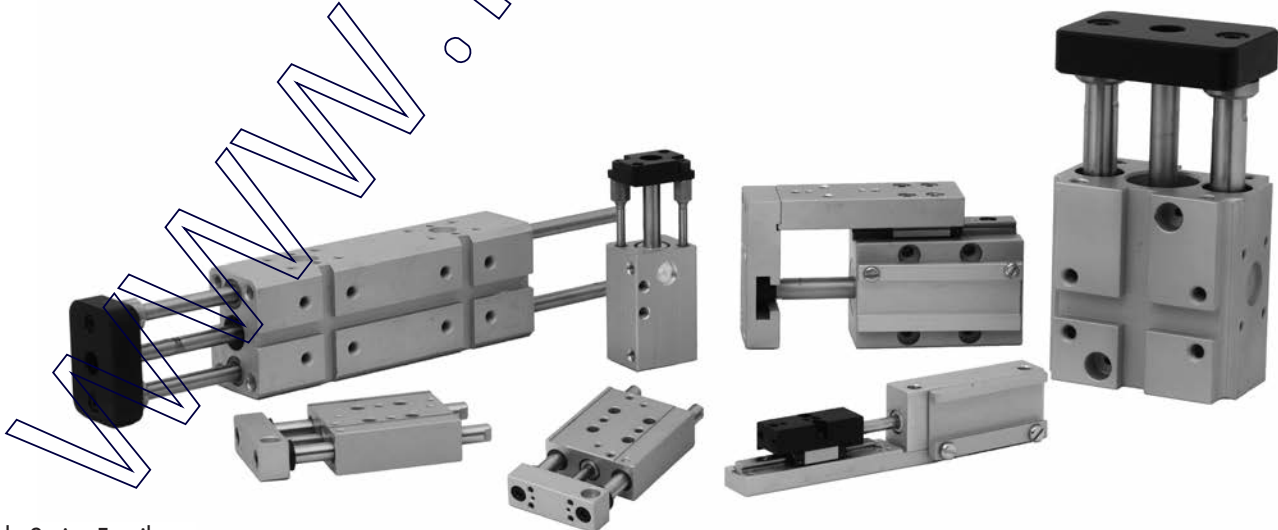

Slide Series Family

GC2000 Guided Cylinders

Unique design provides maximum performance in minimal space and weight.

Introduction

GC2000 Series Guided Cylinders outperform conventional non-rotating cylinders. The GC2000 series is designed for short stroke, limited space applications where a cylinder is needed that guides and supports its own load. GC2000 series cylinders are designed for both torsional and direct side load.

Standard features include: Compact envelope, two external guide rods, long, oil impregnated guide bushings, magnetic piston for limit sensing, two mounting surfaces and a large tooling plate. GC2000 Series Guided Cylinders are not offered over 3" total stroke.

Two external guide rods are heat treated stainless steel. They do not enter the sealed cylinder chamber, yet do not extend from the cylinder walls.

Long, oil impregnated bronze guide bushings are precision fitted into the cylinder's square barrel.

Large diameter central rod is 303 stainless and features an oil impregnated bronze guide bushing.

Black anodized aluminum tooling platform or plate is machined flat and provides a large surface for attachments.

Guided Cylinders are shown retracted. Distance between tooling plate and cylinder face prevents a "pinch point". Cylinders provide high output.

Heavy walled square aluminum barrel features a precision machined cylinder bore for low seal friction. The barrel or "frame" is clear anodized for clean, attractive appearance.

Magnetic piston is standard for limit sensing with Comtronic® solid state sensors.

Both ends are easily removed for rebuilding

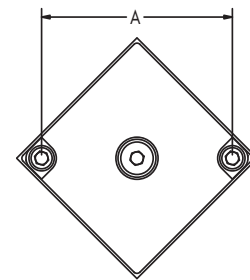
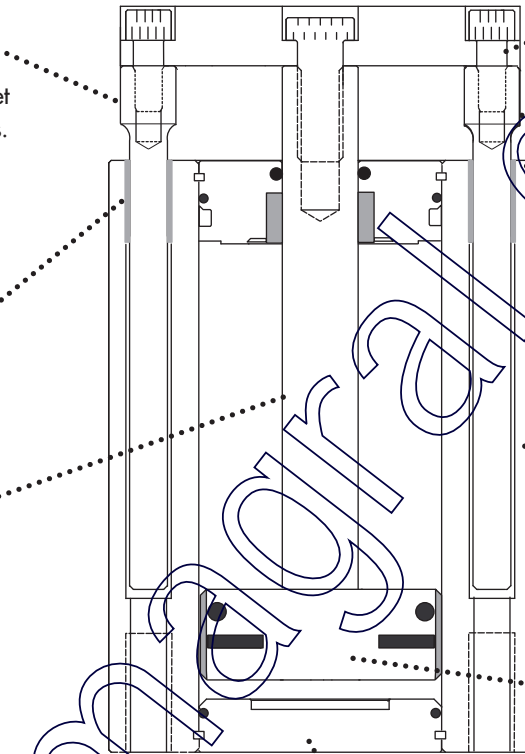

The greater distance between the guide rods ("A") maximizes load bearing capability, yet does not exceed our standard envelope dimensions.

Manufactured under one or more of the following patent numbers: #4,167,134, #4,492,400, #4,566,727, #4,723,503, #4,723,806, #4,903,933, #4,924,758, #5,070,767

How to Order: Guided Cylinders 2000 Series

GC2000 Series Example: GC2118x12-BTPHTV

GUIDED CYLINDER	SERIES	BORE SIZE		STROKE	OPTIONS	SEALS
GC	2	118	X	12	BTP	HTV
1	2	3		4	5	6

1

Style	
GC	Single rod end
GCD	Double rod end

2

Series	
2	2000

3

Bore Sizes	
12	1/2"
34	3/4"
118	1-1/8"
158	1-5/8"
2	2"
3	3"

4

Stroke
Available in imperial measurements in 1/8" increments up to 3".
Example: 12 = 1/2" stroke

5

Options	
Codes	Description
Mounting Brackets	
*ADJ	Retract stroke adjustment (adjustment length must be specified)
BTP	Blank tooling plate
CH	Chrome rod
MB	Multi-mount bracket
RF	Rear Flange
**RW, RWD	Rod wiper
**Cushions	
UC1	Urethane cushion-Front
UC2	Urethane cushion-Rear
UC3	Urethane cushion-Both ends
Ports	
	1/8 NPTF
	1/4 NPTF
*Not available with Double Rod End, UC2 or UC3	
**Not available on 1/2" bore	

6

Standard Seals		
Buna-N-Standard 0° to 200°F		
Pneumatic rating -- Clean-Dry or Lubricated thru 250 PSI (1/2" bore thru 125 PSI)		
LISTINGS BELOW ARE OPTIONAL		
Pneumatic Options		
Code	Description	Temperature
HTV	Hi-temp viton seals	SEE PAGE 10
*CRT	Corrosion resistant seals	SEE PAGE 10
Hydraulic Options		
Code	Description	Temperature
*HYD	Hydraulic seals	0° to 200°F
*VHYD	Hydraulic seals	SEE PAGE 10
Hydraulic rating -- 250 PSI Maximum		
*Not available on 1/2" bore		

**Seal Kits For Rebuild		
Type	Single Shaft	Double Shaft
Standard (Buna-N)	RK<Bore size>	RKD<Bore size>
Hi-Temp viton (HTV)	RKV<Bore size>	RKDV<Bore size>
Teflon (CRT)	RKT<Bore size>	RKDT<Bore size>
Hydraulic (HYD)	RKH<Bore size>	RKDH<Bore size>
Hi-Temp hyd. (VHYD)	RKVH<Bore size>	RKDVH<bore size>
**Seal kits do not include bushings for guide rods		

Example: RKDS

Comtronic® limit sensors — See sensor section for specifications. All guided cylinders are ready to accept Comtronic® sensors WSKL, WSKL-3, WSCL, or WSCL-3 (sensors are sold separately.)

Tools		
Assembly Tools	Code	Bore Sizes
	W1	3/4" - 1-1/8" Bore
	W2	1-5/8" - 3" Bore
Rod End Flat Wrenches	Code	Rod Sizes
	FW1S*	1/4" - 5/16" Dia. Rod (1/2" & 3/4" bore)
	FW2S*	1/2" - 5/8" Dia. Rod (1-1/8, 1-5/8 & 2" bore)
	FW3S*	3/4" Dia. Rod (3" bore)
	FWS**	1 of each listed above
*Set of 3 wrenches		
**Set of 3 wrenches (1 of each size)		

Modifications Welcome

Special stroke lengths, port orientation, mounting configuration.

GC2000 Series - 1/2" Bore

1/2" Bore	Stroke	A	B	C	Approx. Unit Weight (lbs)		
	1/8" - 1/2"	2.36	1-5/8	15/16	GC	.16	GCD
5/8" - 1"	2.86	2-1/8	1-7/16	GC	.20	GCD	.30
1-1/8"-1-1/2"	3.36	2-5/8	1-15/16	GC	.25	GCD	.36

Pressure Rating: Pneumatic Service Only: 5-125 PSI
 Piston Area
 Push .2 in² Pull .15 in²

For detailed specifications on our magnetically activated, solid state, digital output Comtronic® limit sensors, see Sensors section.

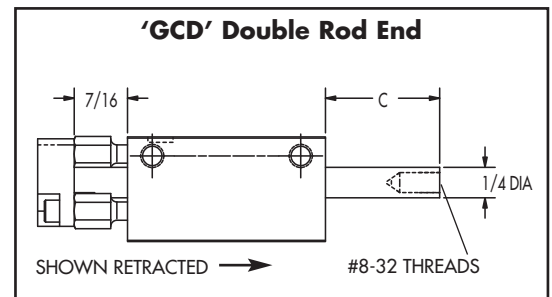
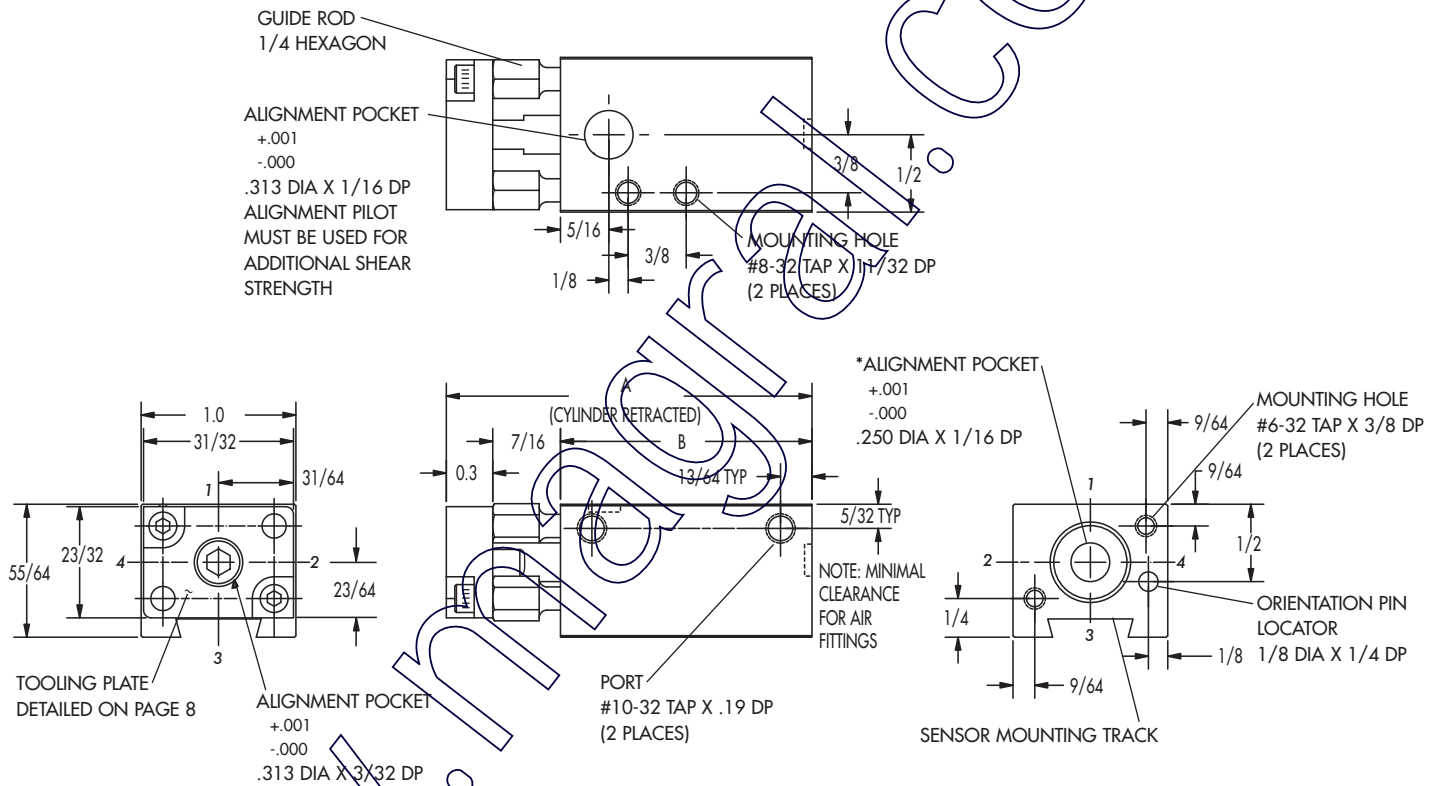
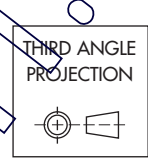

*NOTE: Rear alignment pocket is removed on double ended units, all other information same as above unless noted otherwise.

GC2000 Series - 3/4" and 1-1/8" Bore

	Stroke	A	B	C	D	E	F	G	H	J	K	L	M	N	P	Q	R	S	T	U	V	Approx. Unit Weight (lbs)
3/4" Bore	1/8"-1/2"	1-1/4	1-3/16	2.74	7/16	2.0	7/16	13/32	1/4	.30	31/64	43/64	21/64	.375	5/16	*10-32	3/4	.312	15/16	#10-24	5/16	GC .36 GCD .45
	5/8"-1"	1-1/4	1-3/16	3.24	7/16	2-1/2	7/16	13/32	1/4	.30	31/64	43/64	21/64	.375	5/16	*10-32	3/4	.312	1-7/16	#10-24	5/16	GC .43 GCD .48
	1-1/8"-1-1/2"	1-1/4	1-3/16	3.74	7/16	3.0	7/16	13/32	1/4	.30	31/64	43/64	21/64	.375	5/16	*10-32	3/4	.312	1-15/16	#10-24	5/16	GC .50 GCD .56
	1-5/8"-2"	1-1/4	1-3/16	4.24	7/16	3-1/2	7/16	13/32	1/4	.30	31/64	43/64	21/64	.375	5/16	*10-32	3/4	.312	2-7/16	#10-24	5/16	GC .57 GCD .64
1-1/8" Bore	1/8"-1/2"	1-1/2	1-7/16	2.99	5/8	2.0	13/32	7/16	9/32	.36	21/32	7/8	7/16	.500	1/4	1/8-27	1-1/8	.500	1-1/8	5/16-18	1/2	GC .55 GCD .65
	5/8"-1"	1-1/2	1-7/16	3.49	5/8	2-1/2	13/32	7/16	9/32	.36	21/32	7/8	7/16	.500	1/4	1/8-27	1-1/8	.500	1-5/8	5/16-18	1/2	GC .66 GCD .78
	1-1/8"-1-1/2"	1-1/2	1-7/16	3.99	5/8	3.0	13/32	7/16	9/32	.36	21/32	7/8	7/16	.500	1/4	1/8-27	1-1/8	.500	2-1/8	5/16-18	1/2	GC .74 GCD .89
	1-5/8"-2"	1-1/2	1-7/16	4.49	5/8	3-1/2	13/32	7/16	9/32	.36	21/32	7/8	7/16	.500	1/4	1/8-27	1-1/8	.500	2-5/8	5/16-18	1/2	GC .83 GCD 1.0

*NOTE: 1/8-27 NPT Pipe Tap Optional

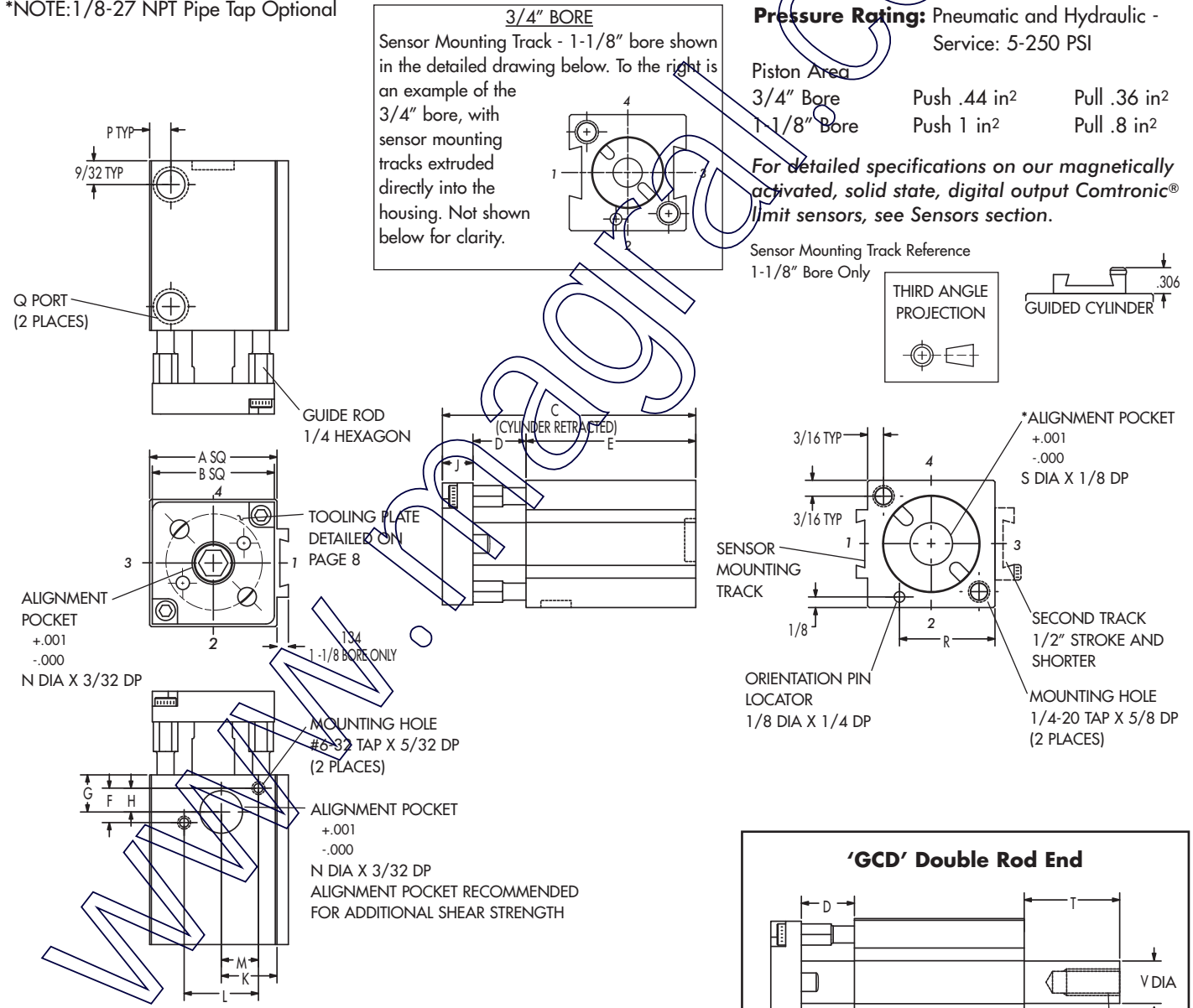

*NOTE: Rear alignment pocket is removed on double ended units, all other information same as above unless noted otherwise.

GC2000 Series - 1-5/8" Bore

1-5/8" Bore	Stroke	A	B	C	Approx. Unit Weight (lbs)	
	1/8"-1/2"	3.37	2-1/4	1-1/8	GC	1
				GCD	1.2	
5/8"-1"	3.87	2-3/4	1-5/8	GC	1.3	
				GCD	1.5	
1-1/8"-1-1/2"	4.37	3-1/4	2-1/8	GC	1.4	
				GCD	1.6	
1-5/8"-2"	4.87	3-3/4	2-5/8	GC	1.5	
				GCD	1.8	

Pressure Rating: Pneumatic and Hydraulic Service: 5-250 PSI
 Piston Area
 Push 2.0 in² Pull 1.7 in²

For detailed specifications on our magnetically activated, solid state, digital output Comtronic® limit sensors, see Sensors section.

Sensor Mounting Track Reference

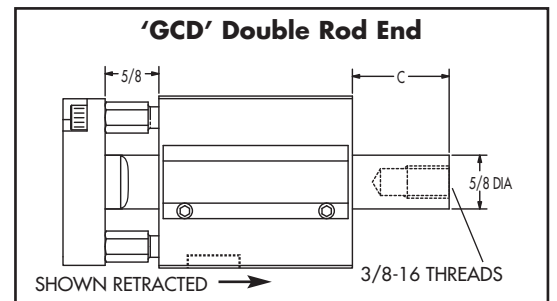
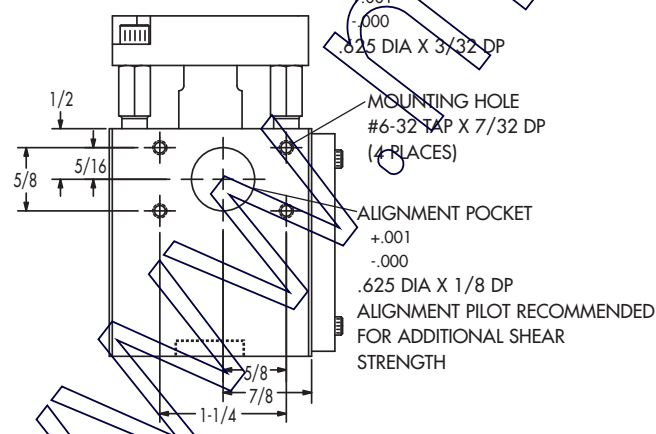
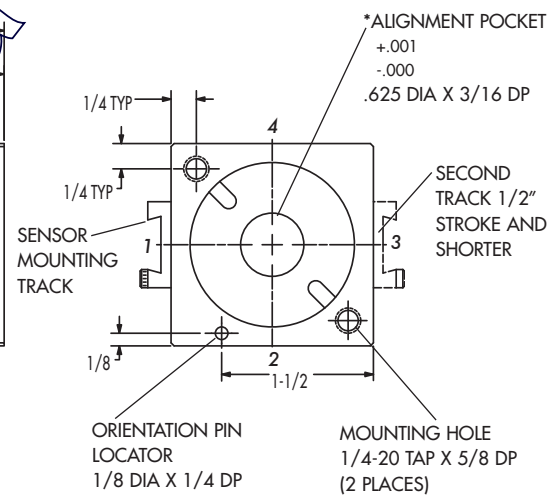
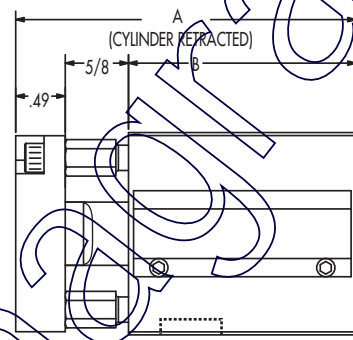
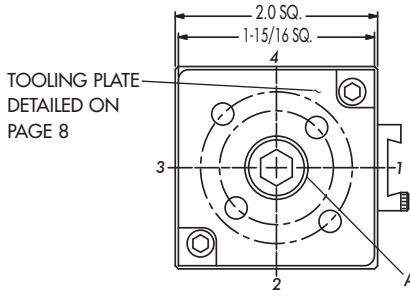
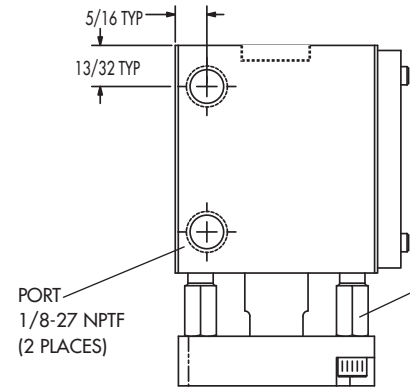
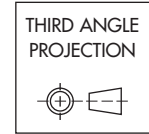
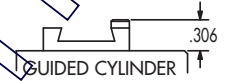

*NOTE: Rear alignment pocket is removed on double ended units, all other information same as above unless noted otherwise.

GC2000 Series - 2" and 3" Bore

	Stroke	A	B	C	D	E	F	G	H	J	K	L	M	N	P	Q	R	S	T	U	V	Approx. Unit Weight (lbs)	
2" Bore	1/8"-1"	2-1/2	2-7/16	3.49	2-3/8	1.0	1.0	1-1/4	1-3/8	.625	#10-24	.625	1/4	5/16-18	1/4	3/4	7/16	1-7/8	1-5/8	3/8-16	5/8	GC 2.0 GCD 2.5	
		1-1/8"-2"	2-1/2	2-7/16	4.74	3-5/8	1.0	1.0	1-1/4	1-3/8	.625	#10-24	.625	1/4	5/16-18	CF	3/4	7/16	1-7/8	2-7/8	3/8-16	5/8	GC 2.2 GCD 2.7
	2-1/8"-3"	2-1/2	2-7/16	5.99	4-7/8	1.0	1.0	1-1/4	1-3/8	.625	#10-24	.625	1/4	5/16-18	CF	3/4	7/16	1-7/8	3-5/8	3/8-16	5/8	GC 2.8 GCD 3.0	
		1-1/8"-2"	3-1/2	3-7/16	3.87	2-3/4	1-1/2	1-3/8	1-3/4	2.0	1.0	1/4-20	1.0	5/16	3/8-16	5/16	13/16	9/16	2-3/4	1-5/8	1/2-13	3/4	GC 3.5 GCD 3.9
	3" Bore	1/8"-1"	3-1/2	3-7/16	5.12	4.0	1-1/2	1-3/8	1-3/4	2.0	1.0	1/4-20	1.0	5/16	3/8-16	CF	13/16	9/16	2-3/4	2-7/8	1/2-13	3/4	GC 4.4 GCD 5.1
			2-1/8"-3"	3-1/2	3-7/16	6.36	5-1/4	1-1/2	1-3/8	1-3/4	2.0	1.0	1/4-20	1.0	5/16	3/8-16	CF	13/16	9/16	2-3/4	3-5/8	1/2-13	3/4

CF = Consult Factory

Pressure Rating: Pneumatic and Hydraulic Service: 5-250 PSI

Piston Area

2" Bore: Push 3.1 in²

Pull 2.8 in²

3" Bore: Push 7 in²

Pull 6.6 in²

For detailed specifications on our magnetically activated, solid state digital output Comtronic® limit sensors, see Sensors section.

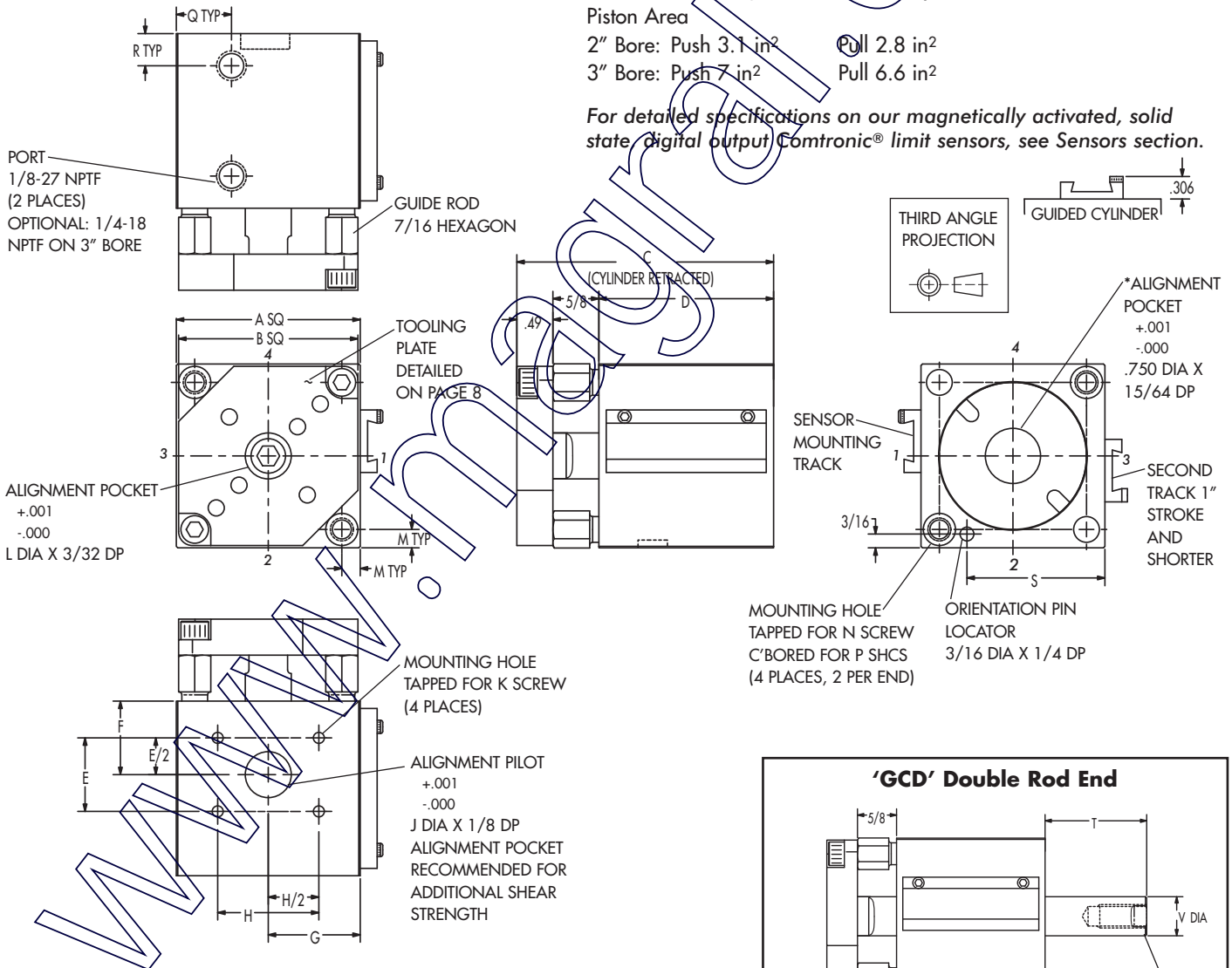

*NOTE: Rear alignment pocket is removed on double ended units, all other information same as above unless noted otherwise.

GC2000 Tooling Plates - Predrilled

Standard on all GC2000 series guided cylinders

Provides easy attachment of Com-Pick grippers, see catalog Grippers. The appropriate part number for standard gripper attachment and mating alignment pilot, shown on the back cover, is listed under each plate for ordering purposes.

1/2" Bore

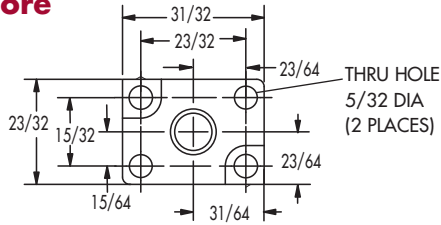

1-5/8" Bore

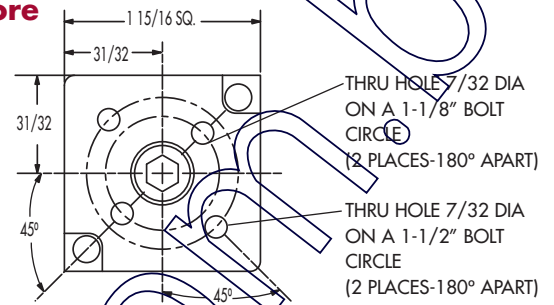

3/4" Bore

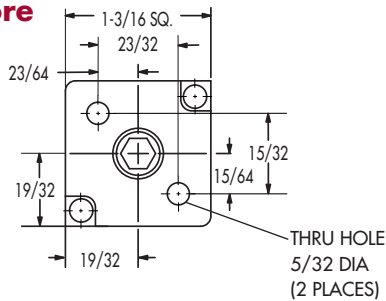

Com-Pick Gripper: **RG072, RG073** - Mating Alignment Pilot: **PL158-07**
 Com-Pick Gripper: **RG112, RG113** - Mating Alignment Pilot: **PL158-11**

Com-Pick Gripper: **SG052** - Mating Alignment Pilot: **PL34-05**

1-1/8" Bore

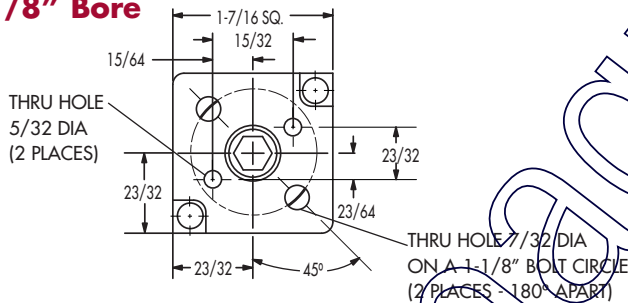

2" Bore

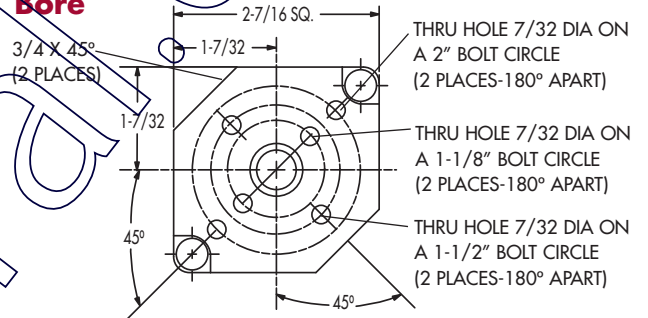

Com-Pick Gripper: **RG072, RG073** - Mating Alignment Pilot: **PL158-07**
 Com-Pick Gripper: **RG112, RG113** - Mating Alignment Pilot: **PL158-11**
 Com-Pick Gripper: **RG162, RG163** - Mating Alignment Pilot: **PL158L**

Com-Pick Gripper: **SG052** - Mating Alignment Pilot: **PL118-05**
 Com-Pick Gripper: **RG072, RG073** - Mating Alignment Pilot: **PL118-07**

Optional: Blank Tooling Plate

Specify: **BTP** after part number Plate may be modified before using. Consult factory for quote on customized tooling plate.

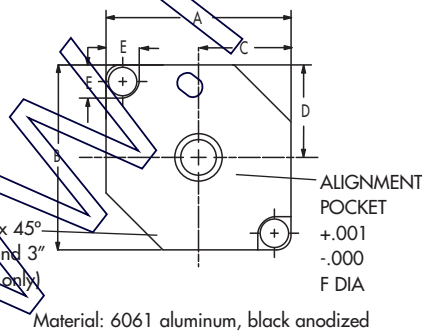

Material: 6061 aluminum, black anodized

Bore	A	B	C	D	E	F
1/2	31/32	23/32	31/64	23/64	17/64	.313 x .18 DP
3/4	1-3/16	1-3/16	19/32	19/32	19/64	.375 x .19 DP
1-1/8	1-7/16	1-7/16	23/32	23/32	19/64	.500 x .25 DP
1-5/8	1-15/16	1-15/16	31/32	31/32	3/8	.625 x .28 DP
2	2-7/16	2-7/16	1-7/32	1-7/32	7/16	.625 x .28 DP
3	3-7/16	3-7/16	1-23/32	1-23/32	1/2	1.00 x .34 DP

3" Bore

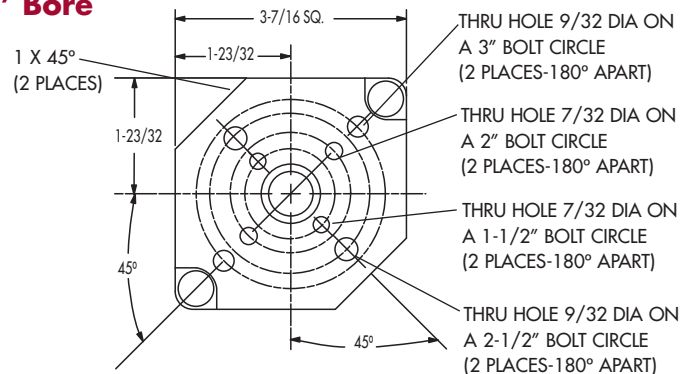

Com-Pick Gripper: **RG112, RG113** - Mating Alignment Pilot: **PL3-11**
 Com-Pick Gripper: **RG162, RG163** - Mating Alignment Pilot: **PL3-16**
 Com-Pick Gripper: **RG202, RG203** - Mating Alignment Pilot: **PL3-20**
 Com-Pick Gripper: **RG252, RG253** - Mating Alignment Pilot: **PL3-20**

GC2000 Optional Multi-Mount Bracket

Specify Option **"MB"** after Part Number. Not available on 2" and 3" bore.

1/2" Bore

Offers four additional mounting options in one common bracket.

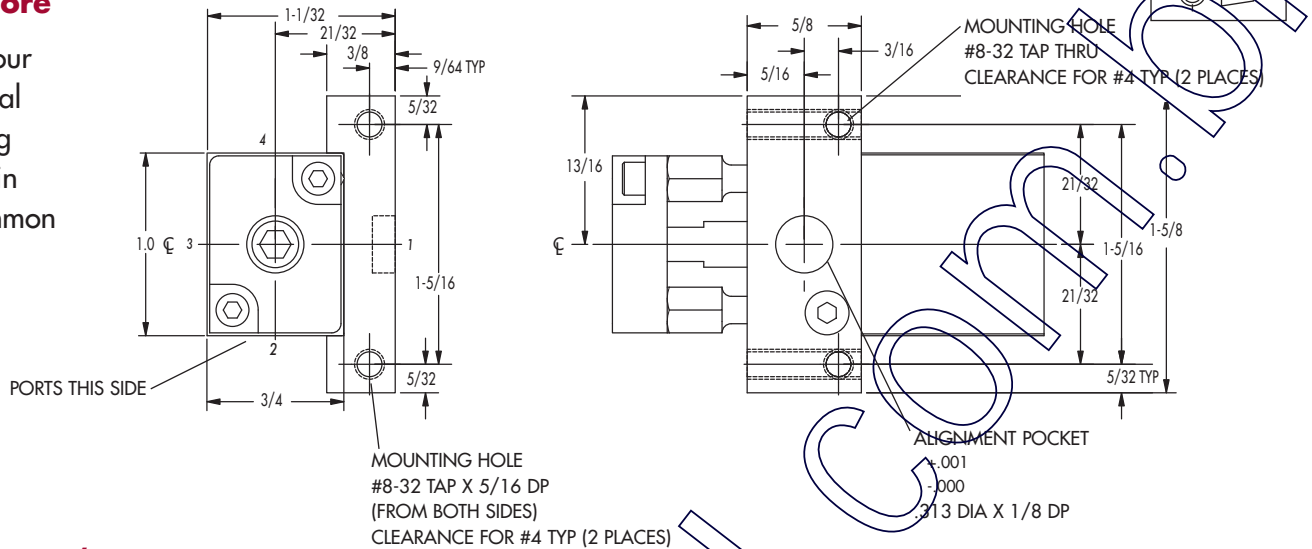

3/4" & 1-1/8" Bore

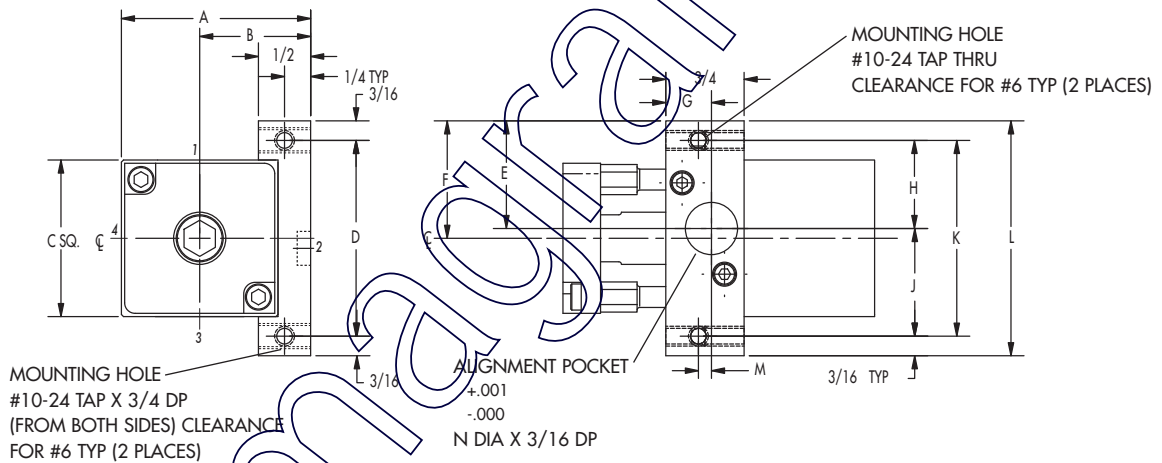

Bore	A	B	C	D	E	F	G	H	J	K	L	M	N
3/4	1-9/16	15/16	1-1/4	1-5/8	55/64	1.0	13/32	43/64	61/64	1-5/8	2.0	1/32	.375
1-1/8	1-13/16	1-1/16	1-1/2	1-7/8	1-1/32	1-1/8	7/16	27/32	1-1/32	1-7/8	2-1/4	1/16	.500

1-5/8" Bore

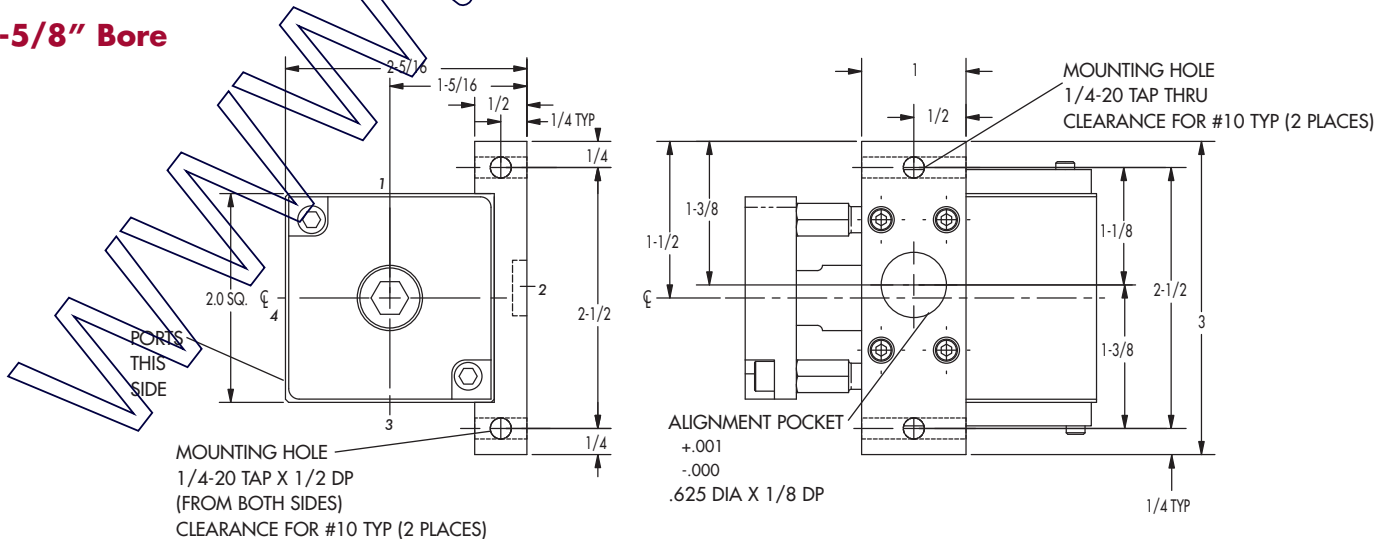

GC2000 Options

Urethane Cushions

Specify suffix **UC1**, **UC2**, or **UC3** when ordering.

Notes:

- Designed for noise reduction and minor piston impact only
- Cylinder length does not increase
- Cushion pads mechanically retained within the endcap

Specifications:

- Pneumatic service only
- Available on 3/4" - 3" bore
Temperature: 0° - 150°F
- Material: Polyurethane

UC1
CUSHION
PADS ON
FRONT END

UC2
CUSHION
PADS ON
REAR END

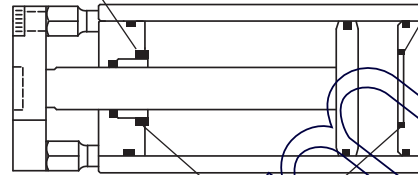

UC3
CUSHION
PADS ON
BOTH ENDS

Urethane ROD WIPER - "RW" or "RWD"

Specify suffix **RW** when ordering single rod cylinders or **RWD** for double rod.

Notes:

- Specify **RW** or **RWD** after cylinder part number
- Applies to piston rod only - does not apply to guide rods
- Positioned flush with cylinder face

Specifications:

- Temperature: Up to 200°F (90°C)
- No additional length added
- Available on the following:

Bore Size	Stroke Length
3/4", 1-1/8", 1-5/8"	1/8" thru 2"
2", 3"	1-1/8" thru 2"

* Not available on 7/8" and 1" stroke.

Seal Options

When used with guided cylinders.

Type	Description	Ordering Suffix	Rating
Pneumatic	Corrosion Resistant Teflon	CRT	250° to 400°F
	High Temp. Viton	HTV	0° to 400° F
Hydraulic	Standard Temp. Hydraulic	HYD	0° to 200° F
	High Temp. Viton Hydraulic	VHYD	0° to 400° F

Notes:

- "CRT" not recommended for use under 250°F
- Comtronic® sensors will not function over 158°F/70°C
- In applications over 400°F, consult the factory before specifying
- Urethane cushion option is for 0° -150°F

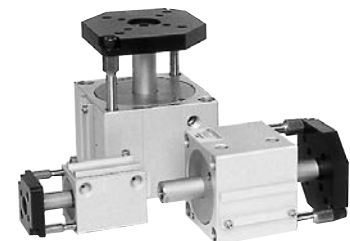

GC2000 Options

Adjustable Retract Stroke - "ADJ"

Specify suffix **ADJ** when ordering.

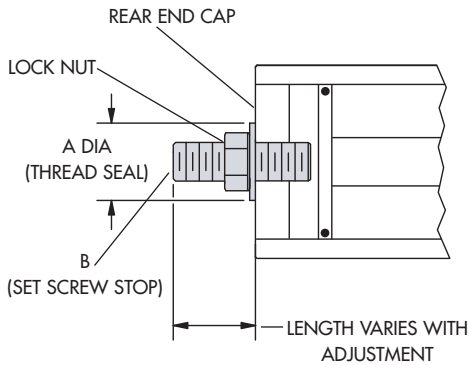

Bore	A	B	Thread Seal	
			Max. Temperature	Max Pressure
1/2	.469	#10-32	200° F	125 PSI
3/4	.562	1/4-20		200 PSI
1-1/8	.750	3/8-16		
1-5/8				
2	1.0	1/2-13		
3	1.375	3/4-10		

Notes:

- Specify **ADJ** and the length of adjustment after cylinder part number. (Ex. GC2118X1ADJ12)
- Not available with any RF, double rod end cylinder, UC2, or UC3.

End Mounting Flange - "RF"

Specify suffix **RF** when ordering.

1/2" Bore

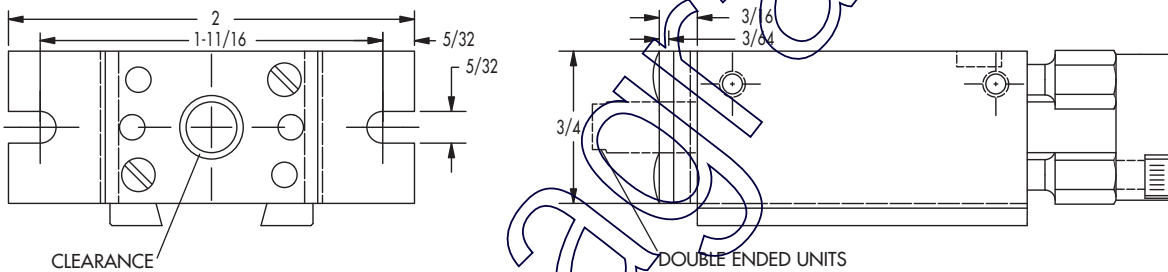

3/4" to 3" Bore

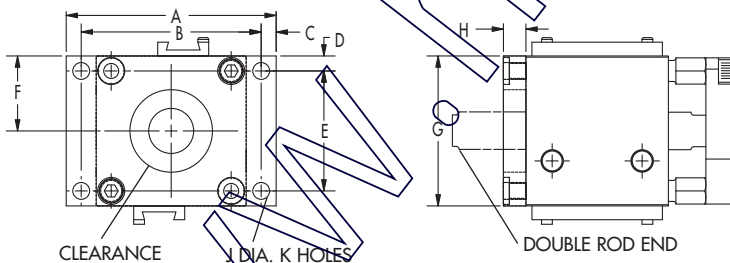

Bore	A	B	C	D	E	F	G	H	J	K
3/4	2-1/4	1-3/4	1/4	5/8	--	5/8	1-1/4	1/4	7/32	2
1-1/8	2-1/2	2	1/4	3/4	--	3/4	1-1/2	1/4	7/32	2
1-5/8	3	2-1/2	1/4	1	--	1	2	1/4	7/32	2
2	3-1/2	3	1/4	1/4	2	1-1/4	2-1/2	3/8	9/32	4
3	4-5/8	4	5/16	5/16	2-7/8	1-3/4	3-1/2	3/8	11/32	4

Notes:

- Mounting flanges for 1-5/8" bore and under have 2 mounting holes on "F" center line.
- All bores over 1-5/8" have 4 holes, as shown above, omitting the 2 on "F" center line.

GC2000 Series Engineering Data - Load Bearing Capacities

Horizontal

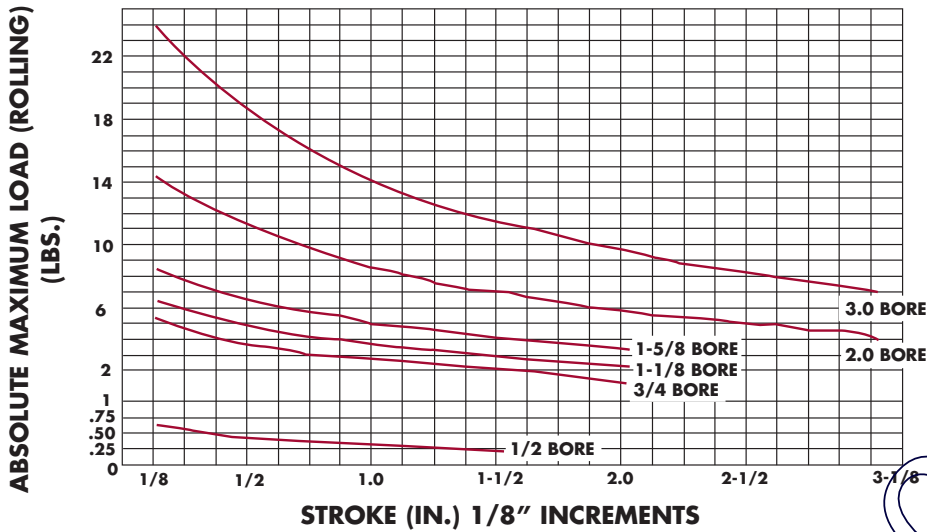

The table to the left is based on loads **centered** on tooling plates. Off center loads will reduce the capacity of the guided cylinder by a factor of the off center length.

Deflection:

- 1" stroke and less = .003" maximum deflection
- 1-1/8"-3" stroke = .006" maximum deflection

Rotational tolerance = +/- 1/2° Max.

Repetitive accuracy = +/- 1/2° Max.

Notes:

- 1.) Deflection will decrease by 35% (or better) on double ended units.
- 2.) Speed controls are recommended to reduce piston impact.

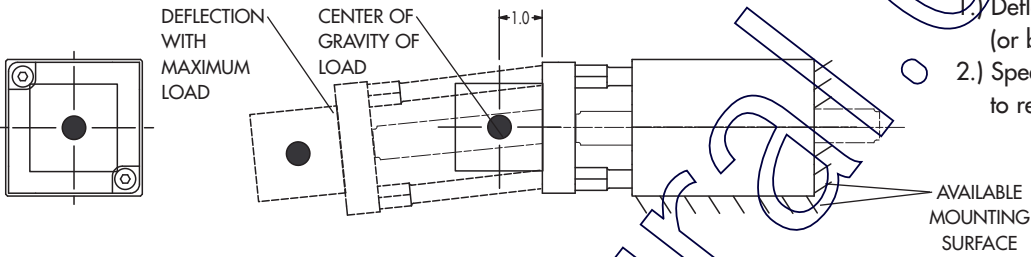

Vertical

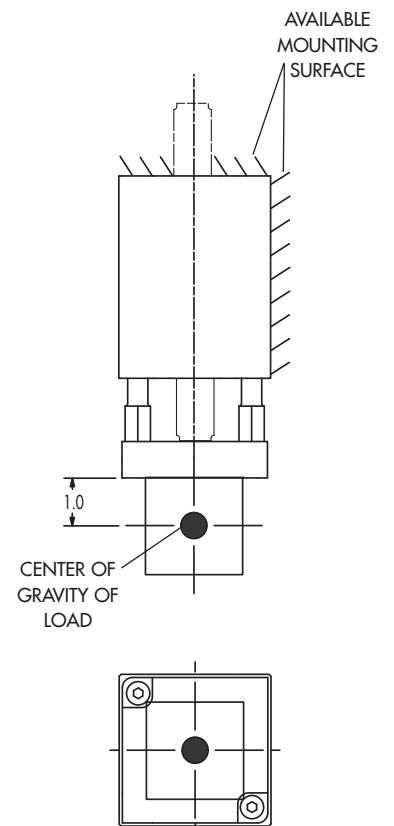
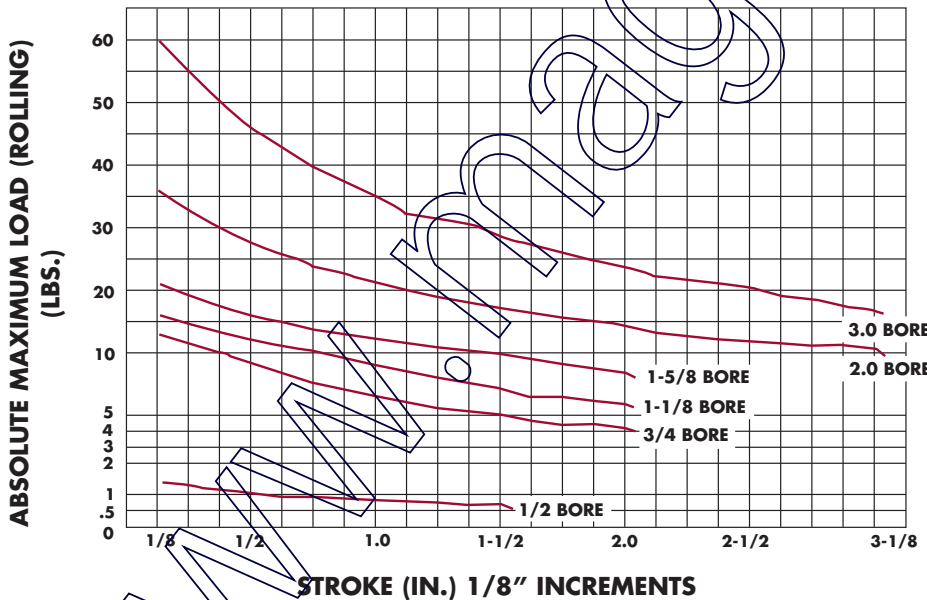

The table above is based on load centered on tooling plates. Off center loads will reduce the capacity of the guided cylinder by a factor of the off center length.

Rotational tolerance = +/- 1/2° Max.

Repetitive accuracy = +/- 1/2° Max.

Note:

- 1.) Speed controls are recommended to reduce piston impact.

GC2000 Series Positive Alignment Pilots

Positive Alignment pockets are standard on all mounting surfaces of GC2000 Series Guided Cylinders. The pilots dimensioned below are designed to fit between the cylinder and the mounting

surface and between the tooling plate and its attachment. They will insure accurate mounting and added shear strength. Pilots are sold separately.

Dual Diameter

Part No.	A	B	C	D
PL34-05	.3747	.249	11/64	3/32
PL118-05	.4997	.249	11/64	3/32
PL118-07	.4997	.312	3/16	7/64
PL158-07	.6247	.312	3/16	7/64
PL158-11	.6247	.499	3/16	7/64
PL3-11	.9997	.499	3/16	7/64
PL3-16	.9997	.624	1/4	11/64
PL-20	.9997	.749	5/16	15/64

Common Diameter

Part No.	A	B
PL12L	.3122	13/64
PL34	.3747	13/64
PL118L	.4997	13/64
PL158L	.6247	19/64

Guided Cylinder - Com-Pick™ Gripper Combination

All guided cylinders come with a tooling plate that features one or more bolt patterns. Some of these bolt patterns match a selection of our 2 or 3 jaw angular type grippers. Page 8 lists which

grippers will fit each plate. Consult our gripper catalog for more data on grippers.

Guided Cylinder with Double Rod Ends

Double ended guided cylinders, style "GCD" provide the most rigid actuators. The large diameter central rod runs through bushings at both ends of the cylinder, reducing deflection by 35%. Do NOT use the double rod end, opposite the tooling plate, as the

non-rotating element. Only the tooling plate is to be used to attach a load. The central rod can be turned if torqued. The double ended rod can also be used to trip external limit or proximity sensor.

Horizontal Axis Application

All non-vertical applications require close observance of the limits set on page 12. Direct side load is always present. Torsional loads are present if the load is not on the direct center. Performance will

deteriorate as the absolute limits are approached. The double rod ended units will improve performance in all horizontal applications.

Vertical Axis Application

Vertical axis applications are inherently less severe than horizontal applications, the limits on page 12 reflect this. Vertical applications do present another problem not reflected in the limits. This problem

is speed and impact when traveling down or with gravity. Speed controls are strongly recommended to reduce piston impact. Excessive impact may cause internal damage.

Limit Sensors

Comtronic® sensors are digital output limit sensors. The supply voltage ranges from 5-24 volts DC. Available in current "sinking" or current "sourcing" outputs. The unique Comtronic® design is 100 times more sensitive than "Hall Effect" sensors, they also have

a moisture tight design with no moving parts to wear, break, bounce or stick. See our sensor section for more information. All Guided Cylinders are ready to accept our Comtronic® sensors.

All products manufactured under 1 or more of the following US patents: #4,167,134... #4,492,400... #4,566,727... #4,723,503... #4,723,806... #4,903,933... #4,924,758... #5,070,767... #5,113,746... #5,117,743... #5,135,329... #5,245,911... #5,269,346... #5,290,981... #5,293,015... #5,333,536... #5,363,742... #5,351,603... #5,437,440... #5,456,161... #5,479,956... #5,522,302... #8,855,605... #89 904 334.3-2301. Other US and Foreign patents pending. The specification in this bulletin are believed to be accurate and reliable. However, it is the responsibility of the product user to determine the suitability of Compact Automation's products for a specific application. While products found by Compact Automation Products to be defective will be replaced, no liability is assumed beyond such replacement. Specifications subject to change without notice.

GC3000 & 4000 Series Introduction

Unique Long Stroke Metric Design Provides the Maximum Performance Cylinder To Guide and Support Its Own Load In A Space Efficient Package

Introduction

GC3000 and GC4000 series guided air cylinders are highly space efficient devices designed to bridge the gap between expensive ball bearing slides and zero load bearing non-rotating cylinders.

The "GC" series cylinders feature two large guide rods outside the sealed cylinder chamber. A third rod, the central cylinder piston rod, is not subjected to the full load, as is the case with all twin rod and twin bore designs. The end result is longer life and less deflection.

The GC3000 features two long guide bushings in the head end. The guide rods do not extend beyond the back of the cylinder body, thus providing a very short overall length and low unit weight.

The GC4000 features four long guide bushings, two per end. The guide rods extend beyond the back of the cylinder body so when the cylinder extends, four point support reduces deflection and extends the life under full loads.

The products in this brochure are part of our World Class Series, designed for the international market. All World Class Series products are 100% metric - Made in USA! Optional imperial thread connections available.

Highly Versatile Design

5 Mounting Surfaces

I.S.O. Ports standard
"G" straight threads

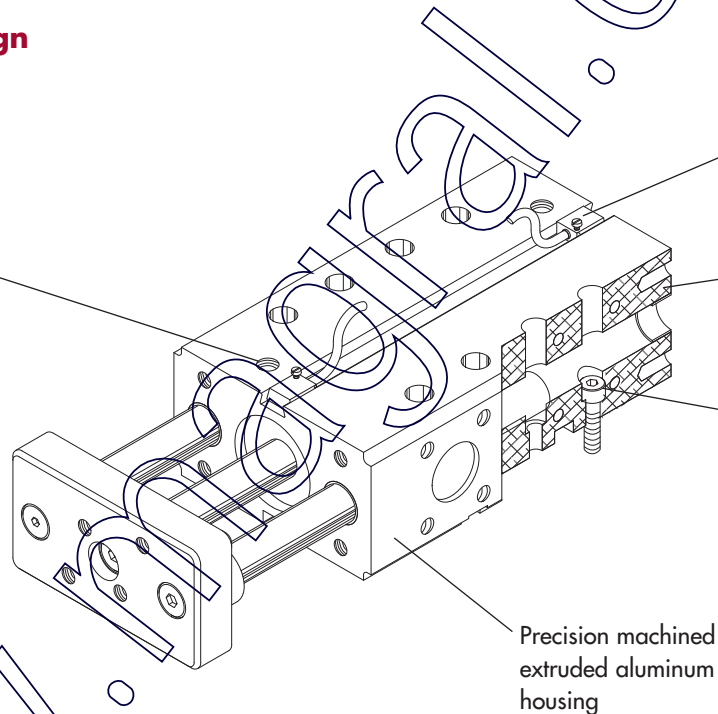

Low profile Comtronic®
sensors sold separately

Double bushing on
GC4000 series only

Extend guide rods for
easy access to thru
mounting, one of the six
ways to mount.

*Standard on 25 and
40mm bore. 12mm
bore has an optional
mounting bracket, see
page 21.

*For thru mounting on
GC4000, guide rods
must be removed.

Precision machined
extruded aluminum
housing

All products manufactured under 1 or more of the following US patents: #4,167,134... # 4,492,400... #4,566,727... #4,723,503... #4,723,806... #4,903,933... #4,924,758... #5,070,767... #5,113,746... #5,117,743... #5,135,329... #5,245,911... #5,269,346... #5,290,981... #5,293,015... #5,333,536... #5,363,742... #5,351,603... #5,437,440... #5,456,161... #5,479,956... #5,522,302... #89 904 334.3-2301. Other US and Foreign patents pending. The specifications in this bulletin are believed to be accurate and reliable. However, it is the responsibility of the product user to determine the suitability of Compact Automation's products for a specific application. While products found by Compact Automation Products to be defective will be replaced, no liability is assumed beyond such replacement. Specifications subject to change without notice. Compact, Husky, Snap-Cap, Clean-Act, Comtronic, and World Class are all registered trademarks of Compact Automation Products, Inc.

How to Order: Guided Cylinders 3000 & 4000 Series

GC3000 AND GC4000 Series Example: GC325X25-HTVOTPSAR



1 Style	
GC	Single
*GCD	Double rod end
*GC3000 series only	

2 Series	
3	3000
4	4000

3 Bore	
12	12mm
25	25mm
40	40mm

4 Stroke	
Available in metric measurements in 5mm increments up to 150mm.	

5 Seals		
Standard Pneumatic Seals, Clean, Dry or Lubricated Buna-N: -10 to 90°C (0° to 200°F)		
Optional Pneumatic Seal		
Code	Description	Ratings
HTV	Hi-Temp Viton Seals	-10 to 200°C (0° to 400°F)
Optional Hydraulic Seal		
HYD	Buna-N Hydraulic Seals	-10 to 120°C (0° to 250°F)
VHYD	Viton Hydraulic Seals	-10 to 200°C (0° to 400°F)
NOTE: "HYD" and "VHYD" not available on 12mm bore		

6 Options	
ADJE	Stroke Adj.-Extend
CH	Chrome Rod
MB	Mounting Bracket
MTP	Modified Tooling Plate
OTP	Oversized Tooling Plate
RF	Rear Flange
SAB/SAE/SAR	Shock Absorber(s)
US*	Imperial Thread Options
Keystock-Page 21	
Pilots-Page 21	
Comtronic™ Sensors-Page 30	
*NOTE: When ordering the US option, the option code should follow the stroke size in the model number.	

Imperial Thread Option (Converts all threads except tooling plate taps and rod taps)

Mounting Hole Conversions	M4X0,7 = Tap #8-32 M5X0,8 = Tap #10-24 M6X1 = Tap 1/4-20 M8X1,25 = Tap 5/16-18
Port Conversions	M5X0,8 = #10-32 G 1/8 PORT = 1/8-27NPTF
Conversions Formulas	BAR to PSI: 1 PSI = .069 BAR Examples: 25 PSI x .069 = 1.7 BAR 10 BAR ÷ .069 = 145 PSI Fractional Inch to Millimeters: 1 inch = 25,4mm and 1mm ÷ 25.4 = 0.03937" Examples: 12mm ÷ 25.4 = .47" .75" x 25.4 = 19,05mm

Seal Kit Part Numbers

Seal Type	12mm Bore		25mm Bore		40mm Bore	
	GC	GCD	GC	GCD	GC	GCD
Standard (Buna-N)	RKW12	RKWD12	RKW25	RKWD25	RKW40	RKWD40
Optional Seals						
Viton	RKWV12	RKWDV12	RKWV25	RKWDV25	RKWV40	RKWDV40
Hydraulic	N/A	N/A	RKWH25	RKWDH25	RKWH40	RKWDH40
Viton Hyd.	N/A	N/A	RKWVH25	RKWDVH25	RKWVH40	RKWDVH40

GC3000 & 4000 Series Design Features

GC3000 Series

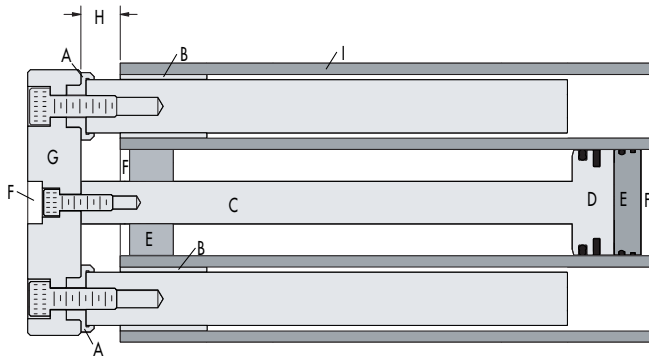

Available Stroke Size: 12mm bore: up to 50mm; 25mm and 40mm bore: up to 150mm

GC4000 Series

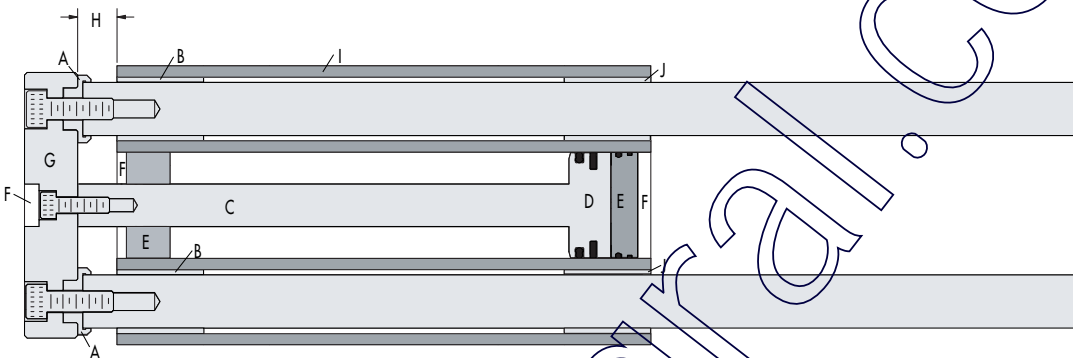

Available Stroke Sizes:
12mm bore: up to 100mm; 25mm and 40mm bore: up to 150mm

A PATENTED GUIDE RODS

Featured two headed external guide rods designed to insure strength and long life. The guide rods do not enter the sealed chamber.

- Guide rod heads made from 300 series stainless steel.
- Guide rods are chrome plated high strength carbon steel.

B BUSHINGS

Long, oil impregnated bronze guide bushings are precision fitted into the cylinder's rectangular housing.

C PISTON ROD

The central rod is "roller burnished" 303 stainless, to reduce friction and "work harden" the outer rod surface.

D MAGNETIC PISTON

Standard for limit sensing with optional Comtronic® solid state sensors.

E 100% REPAIRABLE

Both patented endcaps are easily removed for rebuilding.

F ALIGNMENT FEATURES

Alignment pockets and keyways are conveniently arranged on all mounting surfaces to insure accurate mounting and added shear strength, not all shown. **All keyways, pilots and sides labeled 2, 3 and 4 on the frame are machined parallel to the bore, within 0,07mm.**

G MOUNTING PLATE

Black anodized aluminum tooling plate is machined flat and provides a large surface for attachments.

H SPECIAL FEATURE

Guided cylinders are shown retracted. The distance between the tooling plate and the cylinder face prevents a pinch point.

I COMPACT HOUSING

The housing is made from extruded aluminum and anodized for a clean, attractive appearance. Additional machining of the bore results in low friction and concentricity, contributing to long life. **All keyways, pilots and sides labeled 2, 3 and 4 on the frame are machined parallel to the bore, within 0,07mm.**

J GC4000 SERIES ONLY

Extended guide rods and two additional bronze guide rod bushings provide less deflection and extended life.

GC3000 Series - 12mm Bore

Strokes	10mm-25mm (.39-.98)	30mm-50mm (1.18-1.96)
A	96 (3.77)	121 (4.76)
B	71 (2.79)	96 (3.77)
E	38 (1.49)	63 (2.48)

Imperial Thread Option
 M4X0,7 = US Tap #8-32
 M5X0,8 = US Tap #10-24
 M5X0,8 = US Port #10-32
 See "Ordering Instructions" on page 14

Pressure Rating:

Pneumatic: 8 BAR (117 PSI)
 Hydraulic: Not Available

Piston Area
 Push 113mm² (.17 in²)
 Pull 85mm² (.13 in²)

All Inch Dimensions Shown in
 (Parenthesis)

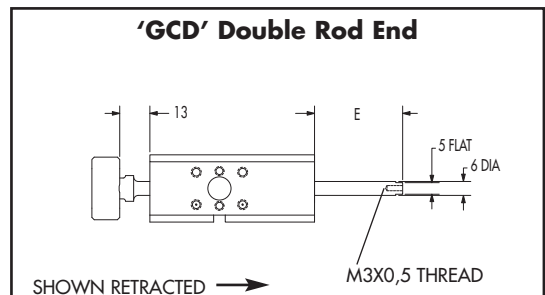
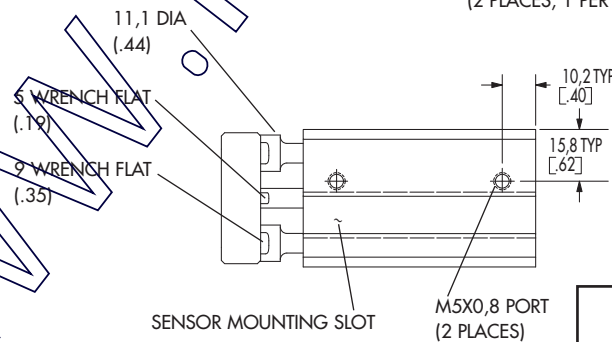
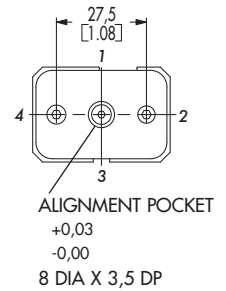
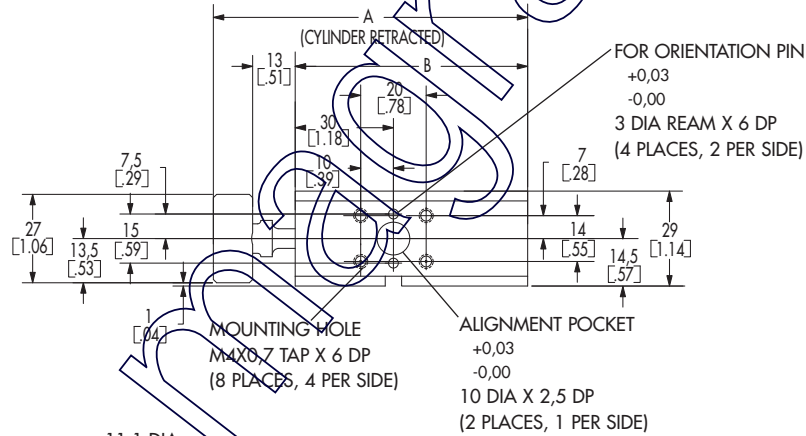
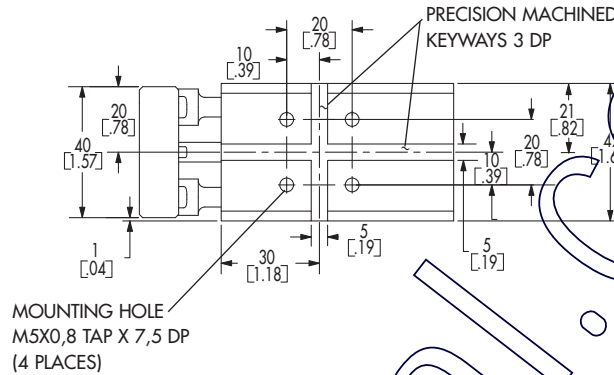
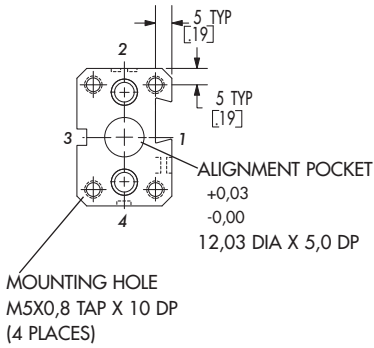

GC3000 Series - 25mm Bore

Strokes	10mm-25mm (.39-.98)	30mm-50mm (1.18-1.96)	55mm-75mm (2.16-2.95)	80mm-100mm (3.14-3.93)	105mm-125mm (4.13-4.92)	130mm-150mm (5.11-5.90)
A	98 (3.85)	123 (4.84)	148 (5.82)	173 (6.81)	198 (7.79)	223 (8.77)
B	70 (2.75)	95 (3.74)	120 (4.72)	145 (5.70)	170 (6.69)	195 (7.67)
C	--	--	87,5 (3.44)	112,5 (4.43)	137,5 (5.41)	162,5 (6.40)
D	--	--	77,5 (3.05)	102,5 (4.04)	127,5 (5.02)	152,5 (6.00)
E	38 (1.49)	63 (2.48)	88 (3.46)	113 (4.45)	138 (5.43)	163 (6.42)

Imperial Thread Option
M4X0,7 = US Tap #8-32
M5X0,8 = US Tap #10-24
M6X1 = US Tap 1/4-20
G 1/8 Port = US 1/8-27 NPTF
See "Ordering Instructions" on page 14

◆NOTE: Recommended for vertical applications only, for horizontal applications use GC4000 series.

Pressure Rating:

Pneumatic and Hydraulic: 15 BAR (217 PSI)

Piston Area

Push 490mm² (.76 in²)

Pull 412mm² (.64 in²)

All Inch Dimensions Shown in (Parenthesis)

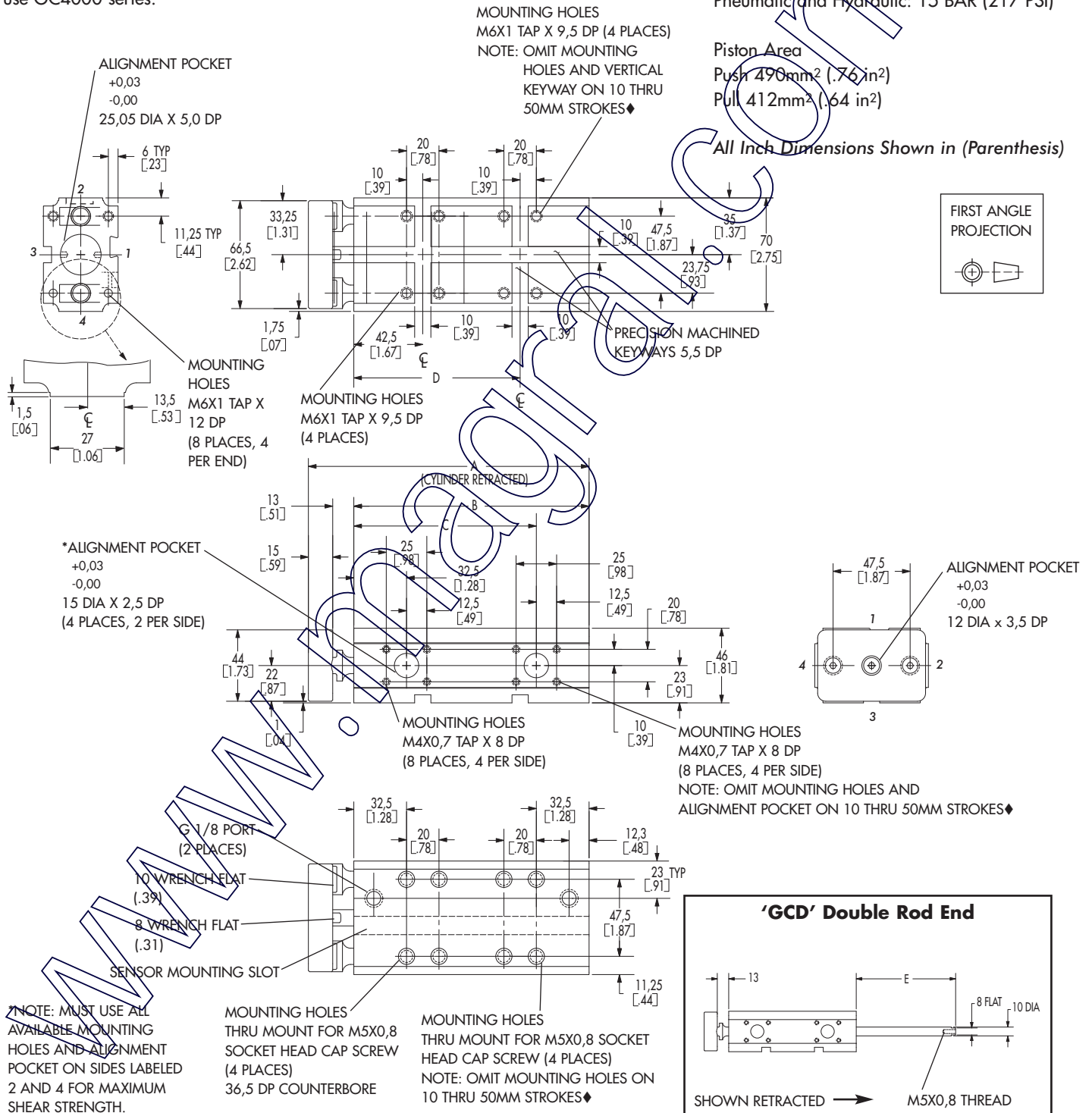

GC3000 Series - 40mm Bore

Strokes	◆ 10mm-50mm (.39-1.96)	◆ 55mm-75mm (2.16-2.95)	◆ 80mm-100mm (3.14-3.93)	105mm-125mm (4.13-4.92)	130mm-150mm (5.11-5.90)	Imperial Thread Option M6X1 = US Tap 1/4-20 M8X1,25 = US Tap 5/16-18 G 1/8 Port = US 1/8-27 NPTF See "Ordering Instructions" on page 14
A	136 (5.35)	161 (6.33)	186 (7.32)	211 (8.30)	236 (9.29)	
B	101 (3.97)	126 (4.96)	151 (5.94)	176 (6.93)	201 (7.91)	
C	--	--	--	131 (5.16)	156 (6.14)	
D	--	--	--	119 (4.69)	144 (5.67)	
E	65 (2.56)	90 (3.54)	115 (4.52)	140 (5.51)	165 (6.49)	

Pressure Rating:

Pneumatic and Hydraulic: 15 BAR (217 PSI)

Piston Area
 Push 1256mm² (1.9 in²)
 Pull 1055mm² (1.6 in²)

All Inch Dimensions Shown in (Parenthesis)

ALIGNMENT POCKET
 +0,03
 -0,00
 40,05 DIA X
 5 DP

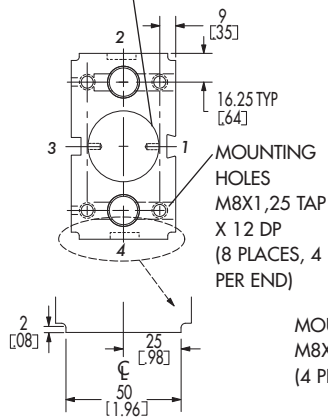

MOUNTING HOLES
 M8X1,25 TAP X 12 DP
 (4 PLACES)
 NOTE: OMIT MOUNTING HOLES
 AND VERTICAL KEYWAY ON
 10 THRU 100MM STROKES◆

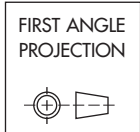
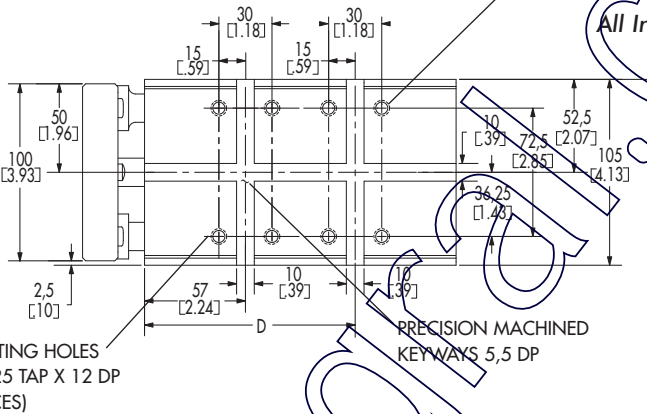

ALIGNMENT POCKET
 +0,03
 -0,00
 25 DIA X 2,5 DP
 (4 PLACES, 2 PER SIDE)

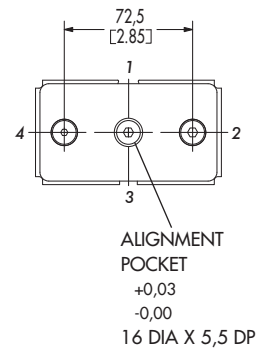
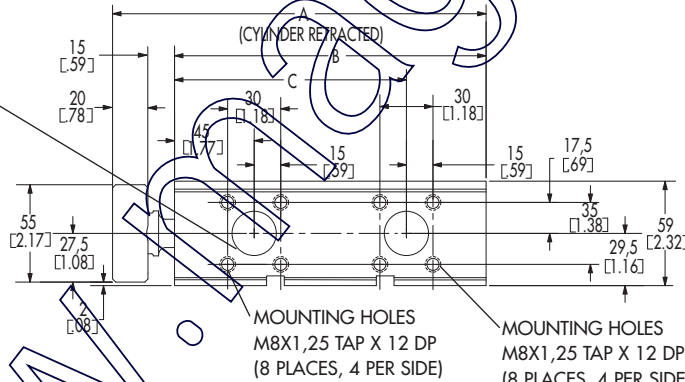

G 1/8 PORT
 (2 PLACES)

23 WRENCH FLAT
 (.91)

13 WRENCH FLAT
 (.51)

SENSOR MOUNTING TRACK

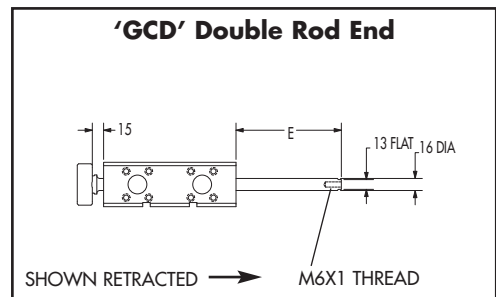
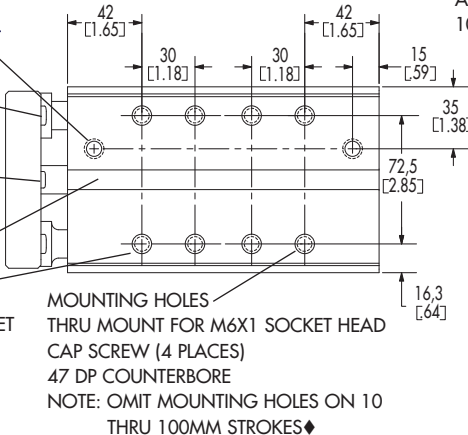

GC4000 Series - 12, 25 and 40mm Bore

12mm Bore

Same cylinder as GC3000 series, except for dimensions detailed below.
All Inch Dimensions Shown In (Parentheses)

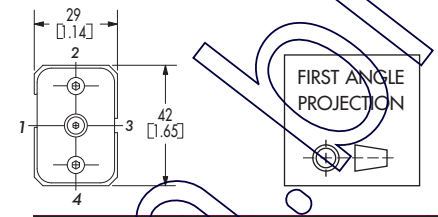
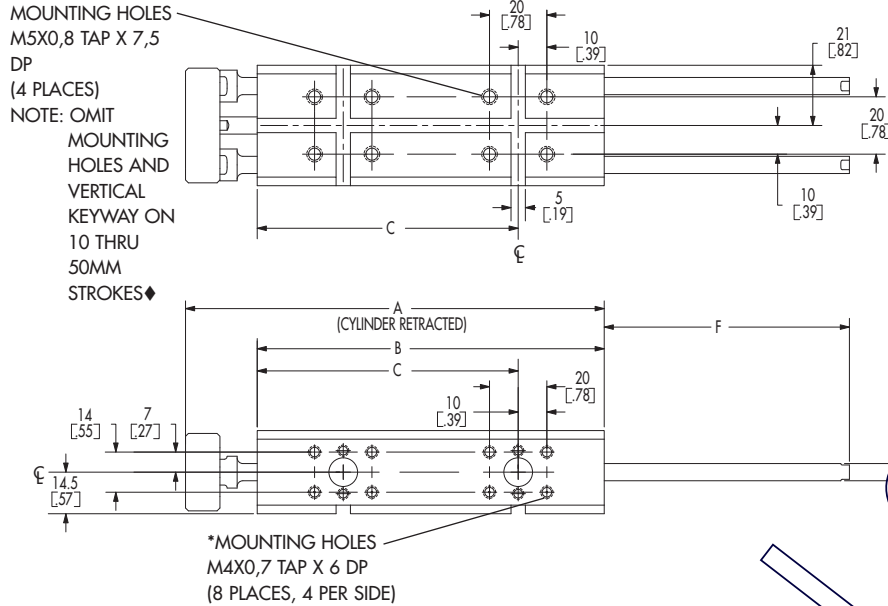

Strokes	A	B	C	F
◆ 10mm-25mm (.39-.98)	96 (3.77)	71 (2.79)	Not Accessible	35,5 (1.40)
◆ 30mm-50mm (1.18-1.96)	121 (4.76)	96 (3.77)	Not Accessible	60,5 (2.38)
55mm-75mm (2.16-2.95)	146 (5.74)	121 (4.76)	91 (3.58)	85,5 (3.37)
80mm-100mm (3.14-3.93)	171 (6.73)	146 (5.74)	116 (4.56)	110,5 (4.35)

*NOTE: Must use all available mounting holes and alignment pocket on sides labeled 2 and 4 for maximum shear strength.

- NOTES: 1. OMIT MOUNTING HOLES, REAMED HOLES AND ALIGNMENT POCKET ON 10 THRU 50MM STROKES◆
2. SEE PAGE 17 FOR OTHER DIMENSIONS.

25mm Bore

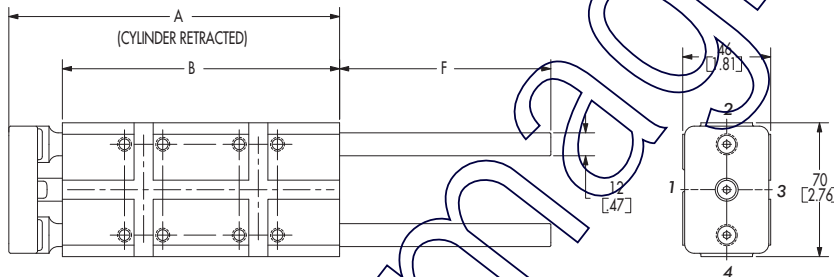

- NOTE: 1. OMIT MOUNTING HOLES, REAMED HOLES AND ALIGNMENT POCKET ON 10 THRU 50MM STROKES◆
2. SEE PAGE 18 FOR OTHER DIMENSIONS.

Strokes	A	B	F
10mm-25mm (.39-.98)	98 (3.85)	70 (2.75)	35,5 (1.40)
30mm-50mm (1.18-1.96)	123 (4.84)	95 (3.74)	60,5 (2.38)
55mm-75mm (2.16-2.95)	148 (5.82)	120 (4.72)	85,5 (3.37)
80mm-100mm (3.14-3.93)	173 (6.81)	145 (5.70)	110,5 (4.35)
105mm-125mm (4.13-4.92)	198 (7.79)	170 (6.69)	135,5 (5.33)
130mm-150mm (5.11-5.90)	223 (8.77)	195 (7.67)	160,5 (6.32)

40mm Bore

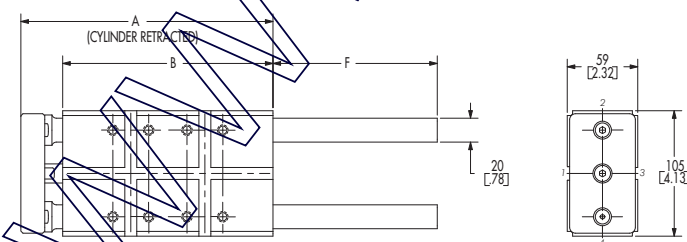

- NOTE: 1. OMIT MOUNTING HOLES, REAMED HOLES AND ALIGNMENT POCKET ON 10 THRU 100MM STROKES◆
2. SEE PAGE 19 FOR OTHER DIMENSIONS.

Strokes	A	B	F
10mm-50mm (.39-1.96)	136 (5.35)	101 (3.97)	62,5 (2.46)
55mm-75mm (2.16-2.95)	161 (6.33)	126 (4.96)	87,5 (3.44)
80mm-100mm (3.14-3.93)	186 (7.32)	151 (5.94)	112,5 (4.43)
105mm-125mm (4.13-4.92)	211 (8.30)	176 (6.93)	137,5 (5.41)
130mm-150mm (5.11-5.90)	236 (9.29)	201 (7.91)	162,5 (6.40)

GC3000 & 4000 Series Accessories

Multi-Mount Bracket

Specify **"MB"** After Cylinder Part Number

Available on 12 mm Bore Only

NOTE:

The "MB" option allows the 12mm bore to be thru mounted. Thru mount is standard on all other bore sizes. Not available with imperial taps.

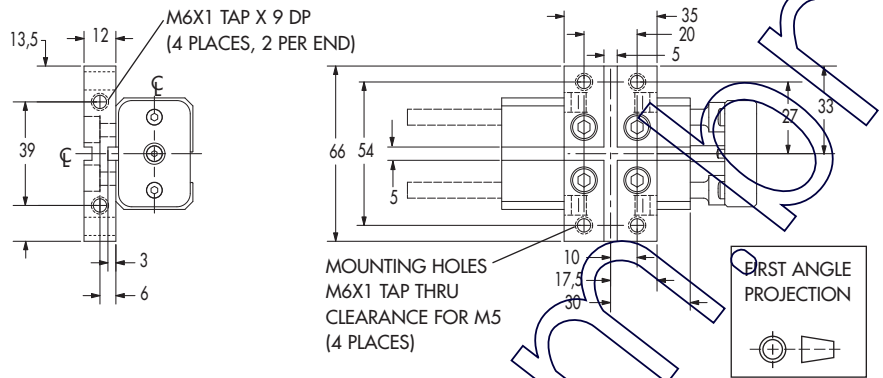

Mounting Flange

Usable on Single or Double Rod Ends. Specify **"RF"** or **"FF"** After Cylinder Part Number

Rear Flange (shown) - Specify **"RF"**

- Available On 12, 25 and 40mm Bore

Front Flange - Specify **"FF"**

- Available on 25 and 40mm Bore

- Caution: finger trap created. User must provide proper guards.

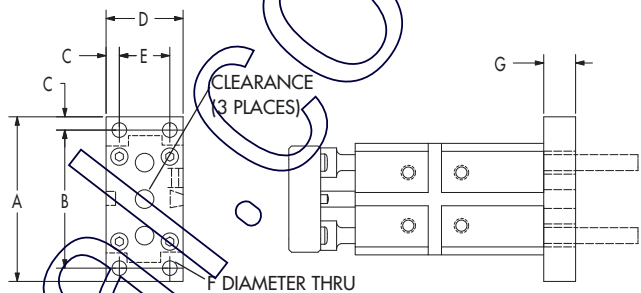

Bore	A	B	C	D	E	F	G
12mm	62	52	5	29	19	5,5	12
25mm	87	76,5	5,25	46	35,5	6,5	12
40mm	135	121	7	59	45	8,5	15

Alignment Features

Precision machined alignment pockets and keyways are conveniently supplied on all metric guided cylinders. The pilots and keys below are sold separately.

Pilots

Common Diameter

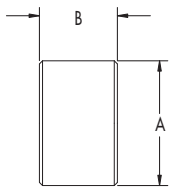

Part No.	A	B
WPL12S	8	6
WPL12M	10	4
WPL12L	12	10
WPL25S	12	6
WPL25M	15	4
WPL25L	25	10
WPL40S	16	10
WPL40M	25	4
WPL40L	40	10

Dual Diameter

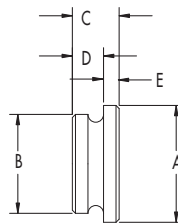

Part No.	A	B	C	D	E
PL12-516	10	5/16"	6	4	2
PL12-38	12	3/8"	15	10	5
PL25-12	15	1/2"	6	4	2
PL25-78	25	7/8"	15	10	5
PL40-78	25	7/8"	6	4	2
PL40-138	40	1-3/8"	15	10	5

Keystock

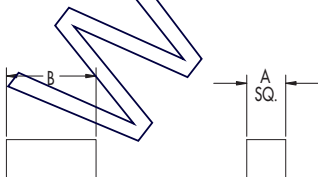

Part No.	A	B
5KEYS	5	13
5KEYL	5	34
10KEYS	10	23
10KEYL	10	58

Chrome Rod Specify: **"CH"**

This applies to the piston rod only, not the guide rods. The piston rod is 303 stainless as standard. This option is for applications used in a horizontal axis and with maximum load capacity. Specify "CH" after the cylinder part number. (CH = Carbon steel, hard chrome plated)

GC3000 & 4000 Series Accessories

Adjustable Stroke Collars

Specify "**ADJE**" After Cylinder Part Number
 Example: GC412x25-ADJE

Bore	A	B	C
12mm	0,69 (.02)	15,88 (.62)	7,14 (.28)
25mm	3,04 (.11)	28,58 (1.12)	10,31 (.40)
40mm	4,39 (.17)	41,28 (1.62)	12,7 (.50)

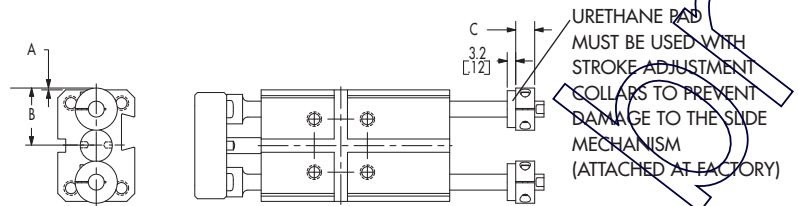

GC4000 Series only - see page 20

CAUTION: FINGER TRAP CREATED. USER MUST PROVIDE PROPER GUARDS.

NOTES:

- 1.) This option is not available with "SAE", "SAB" or "RF" option.
- 2.) Material: Steel, black oxide finish.
- 3.) Supplied with metric hex key wrench for adjustment of collars. (Not offered with inch fasteners.)

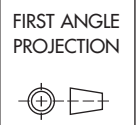

SHOCK ABSORBER OPTION

Specify: "SAR" Shock Absorber Retract stroke - GC3000/GC4000 series models -
 "SAE" Shock Absorber Extend stroke - GC4000 series models only -
 "SAB" Shock Absorber Retract and Extend stroke - GC4000 series models only -

12mm & 25mm Bore

NOTES:

- a.) Shock absorber stroke is: 5mm on **12mm bore** and 6mm on **25mm bore**. Do not bottom out. Allow 0,5mm before end of stroke.
- b.) One shock per end
- c.) Cycle rate: 40 cycles per minute maximum with maximum load. Faster cycle rates are possible with reduced load.
- d.) Mounting holes on each end of cylinder body are not usable with this option due to close proximity to shock absorbers.

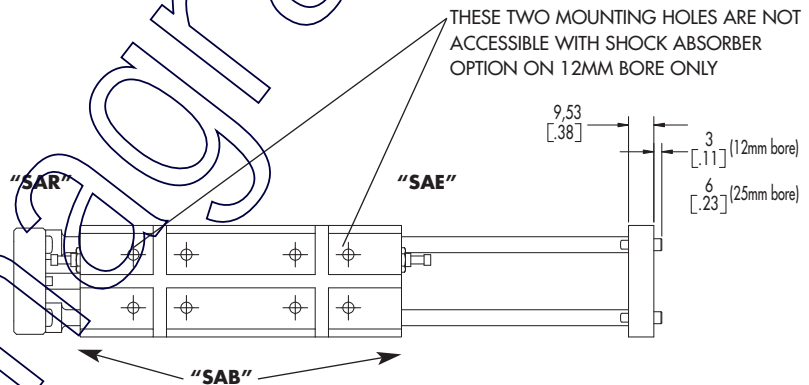

This option is not available with "ADJE", "RF" or "FF" option.

40mm Bore

NOTES:

- a.) Shock absorber stroke is 6mm. Do not bottom out. Allow 0,5mm before end of stroke.
- b.) Two shocks per end
- c.) Cycle rate: 40 cycles per minute maximum with maximum load. Faster cycle rates are possible with reduced load.

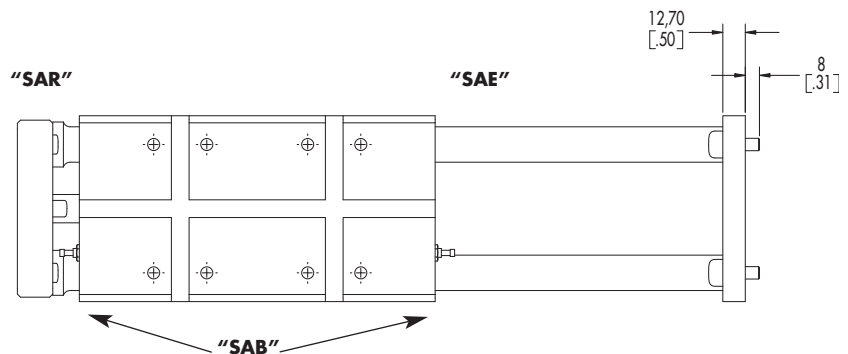

This option is not available with "ADJE", "RF" or "FF" option.

GC3000 & 4000 Series Tooling Plates

Modified Tooling Plate - Specify: "MTP"

After Cylinder Part Number

- NOTES: 1.) This tooling plate will be attached to the guide rods with a liquid thread locker before leaving the factory.
 2.) Not available with inch taps.
 3.) If this tooling plate is removed, reattached the plate to the guide rods with a liquid thread locker.

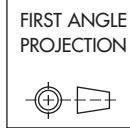

Oversized Blank - Specify: "OTP"

After Cylinder Part Number

- NOTES: 1.) If this tooling plate is removed, reattached the plate to the guide rods with a liquid thread locker.
 2.) This tooling plate should be attached with thread locker before use.

12mm Bore

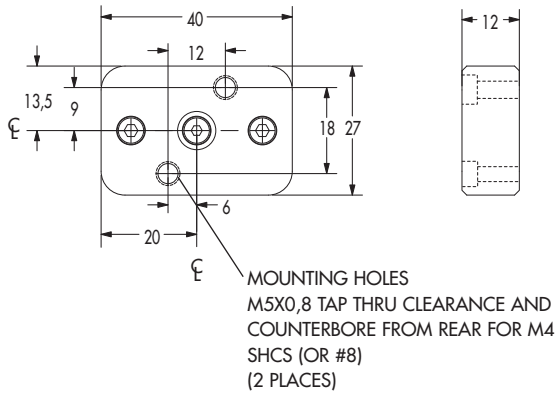

12mm Bore

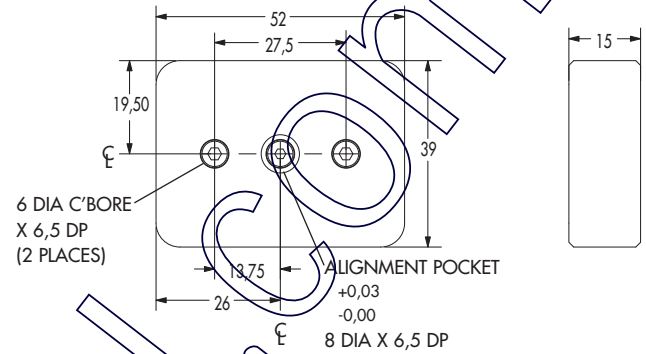

25mm Bore

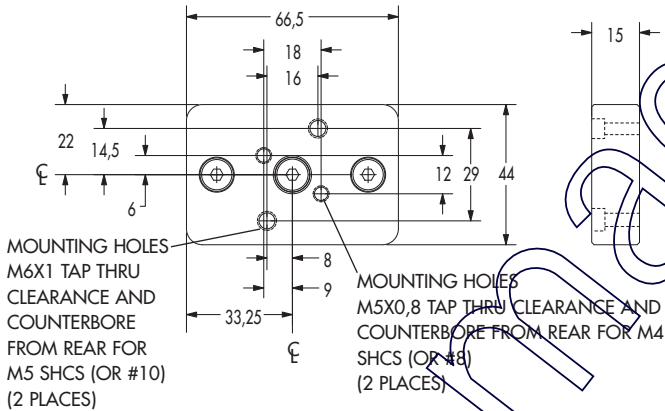

25mm Bore

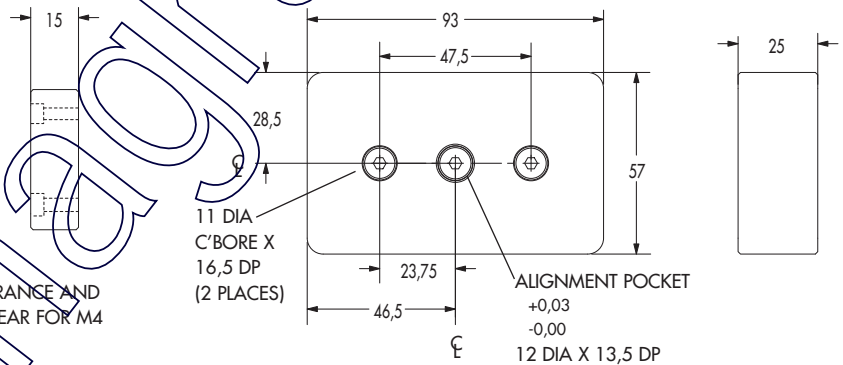

40mm Bore

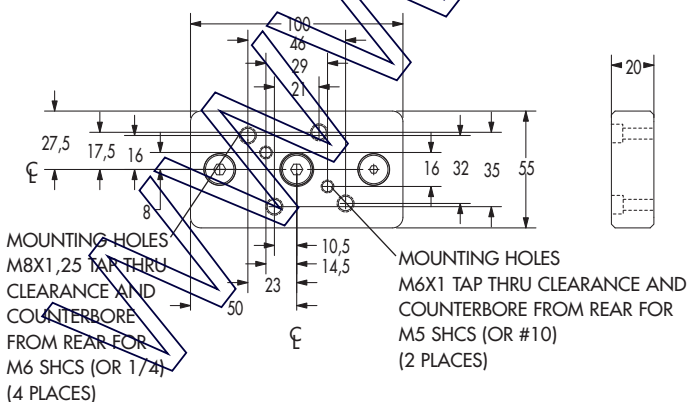

40mm Bore

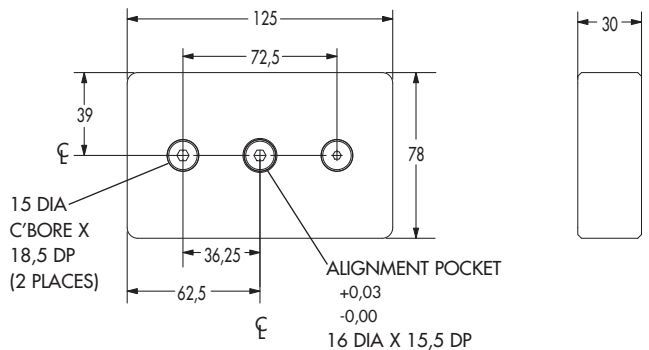

GC3000 & 4000 Accessories, Unit Weights & Recommendations

Urethane Cushion

Specify: **UC1**, **UC2**, or **UC3** after the part number. **Guide rods not shown for clarity.**

- 1.) No extra length added to the cylinder body.
- 2.) Material: Polyurethane pads mechanically retained within the endcap.
- 3.) Designed for noise reduction and minor piston impact.
- 4.) Operating temperatures: -10°C to 66°C (0° to 150°F)

Not available on 12mm bore.

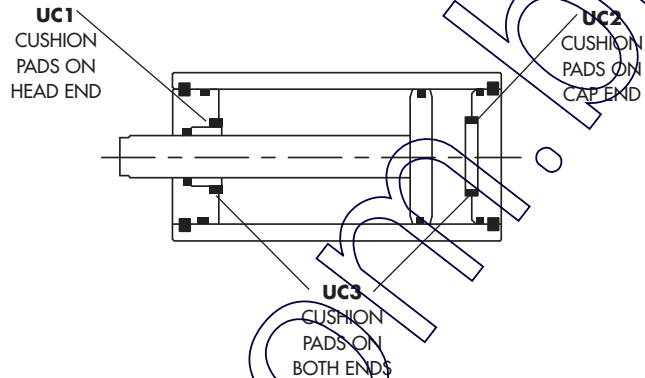

See Flow Controls catalog for dimensional and technical data.

Approximate Unit Weights in Kilograms

GC3000 (Complete unit: cylinder, guide rods, tooling plate)

Conversion **Kilogram X 2.2 = Pounds**

Bore	Stroke Length					
	10-25mm	30-50mm	55-75mm	80-100mm	105-125mm	130-150mm
12mm	,42	,50	NA	NA	NA	NA
25mm	,86	1,07	1,21	1,42	1,61	1,82
40mm	2,24	2,31	2,75	3,15	3,51	3,95

GC4000 (Complete unit: cylinder, guide rods, tooling plate)

Bore	Stroke Length					
	10-25mm	30-50mm	55-75mm	80-100mm	105-125mm	130-150mm
12mm	,46	,55	,59	,67	NA	NA
25mm	,99	1,22	1,44	1,68	2,15	2,37
40mm	2,48	2,73	3,30	3,82	4,32	4,88

12mm Bore

Options	Kilograms
ADJE	,08
MB	,05
MTP	,03
OTP	,08
RF	,05
SA_(R,E)	,01
SAB	,02

25mm Bore

Options	Kilograms
ADJE	,10
BTP	,11
MB	NA
MTP	,10
OTP	,33
RF	,10
SA_(R,E)	,02
SAB	,04

40mm Bore

Options	Kilograms
ADJE	,20
BTP	,27
MB	NA
MTP	,25
OTP	,78
RF	,25
SA_(R,E)	,04
SAB	,08

GC3000 & 4000 Engineering Recommendations

Flow controls are a must on all GC3000 and GC4000 series guided cylinder. High velocities and high loads will damage components in the slide mechanisms. Flow controls must be used to reduce velocities and extend the life of the slides. When high velocities or cycle rates are required, shock absorbers must be used to reduce impact at the ends of the slides stroke.

GC3000 series can be provided with shock absorbers for the retract stroke. the customer should provide an external shock absorber for the extended stroke.

GC4000 series can be provided with shock absorbers on both the extended and retract strokes.

GC3000 & 4000 Side Load Capacities and Moment Ratings

Engineering Recommendations:

- 1.) Flow controls are recommended on all GC3000 and GC4000 series guided cylinders. High velocities and high loads will damage components in the slide mechanism. Flow controls should be used to reduce velocities and extend the life of the slides. When high velocities or cycles rates are required, shock absorbers must be used to reduce impact at the ends of each stroke.
- 2.) Maximum actuator speed of 1m/sec. at no load.
- 3.) Deflections shown in the charts are typical. Slight variations in actual deflection should be expected due to manufacturing tolerances.

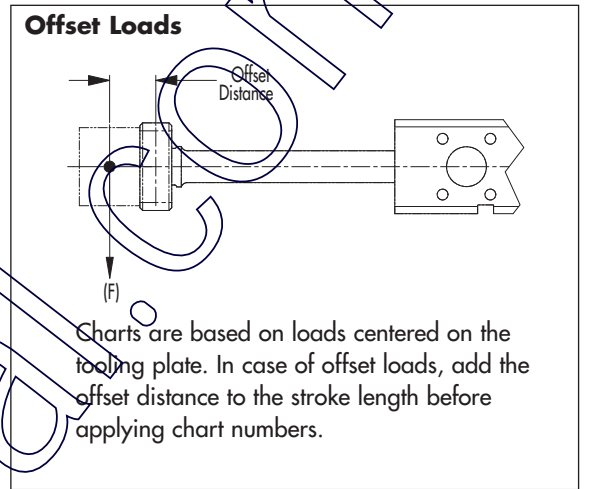
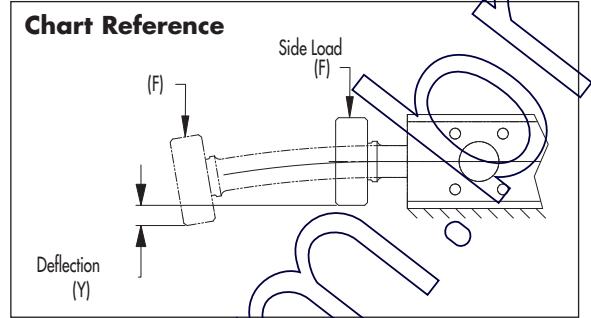

GC3000 Series Side Load Capacities

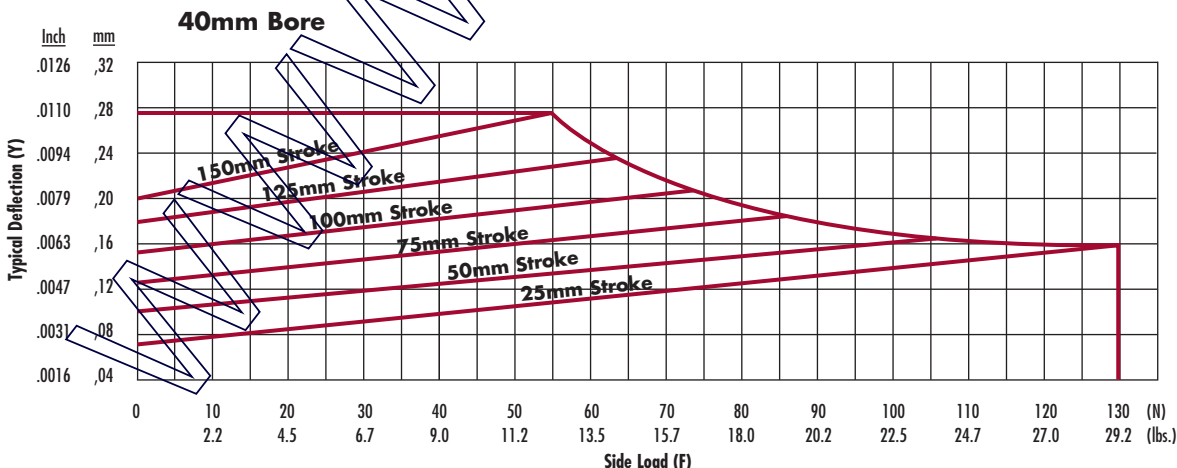
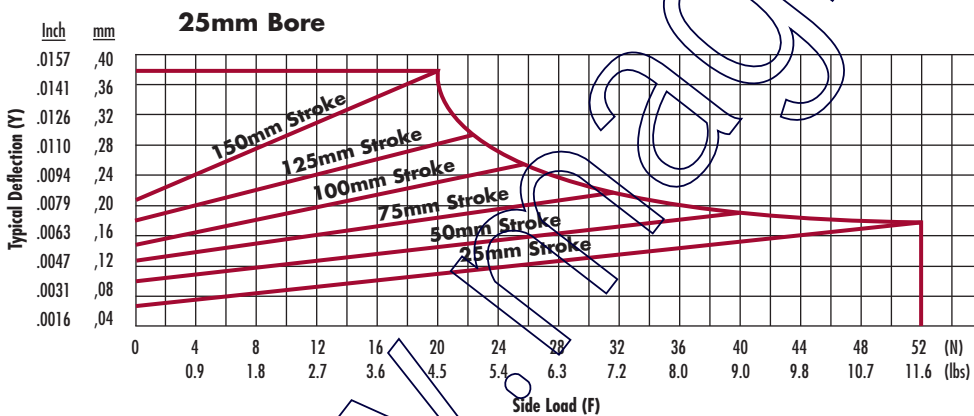
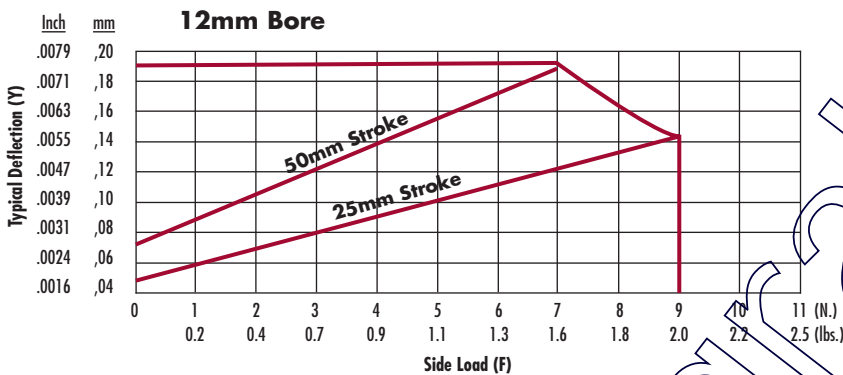

GC3000 & 4000 Side Load Capacities and Moment Ratings

GC4000 Series Side Load Capacities

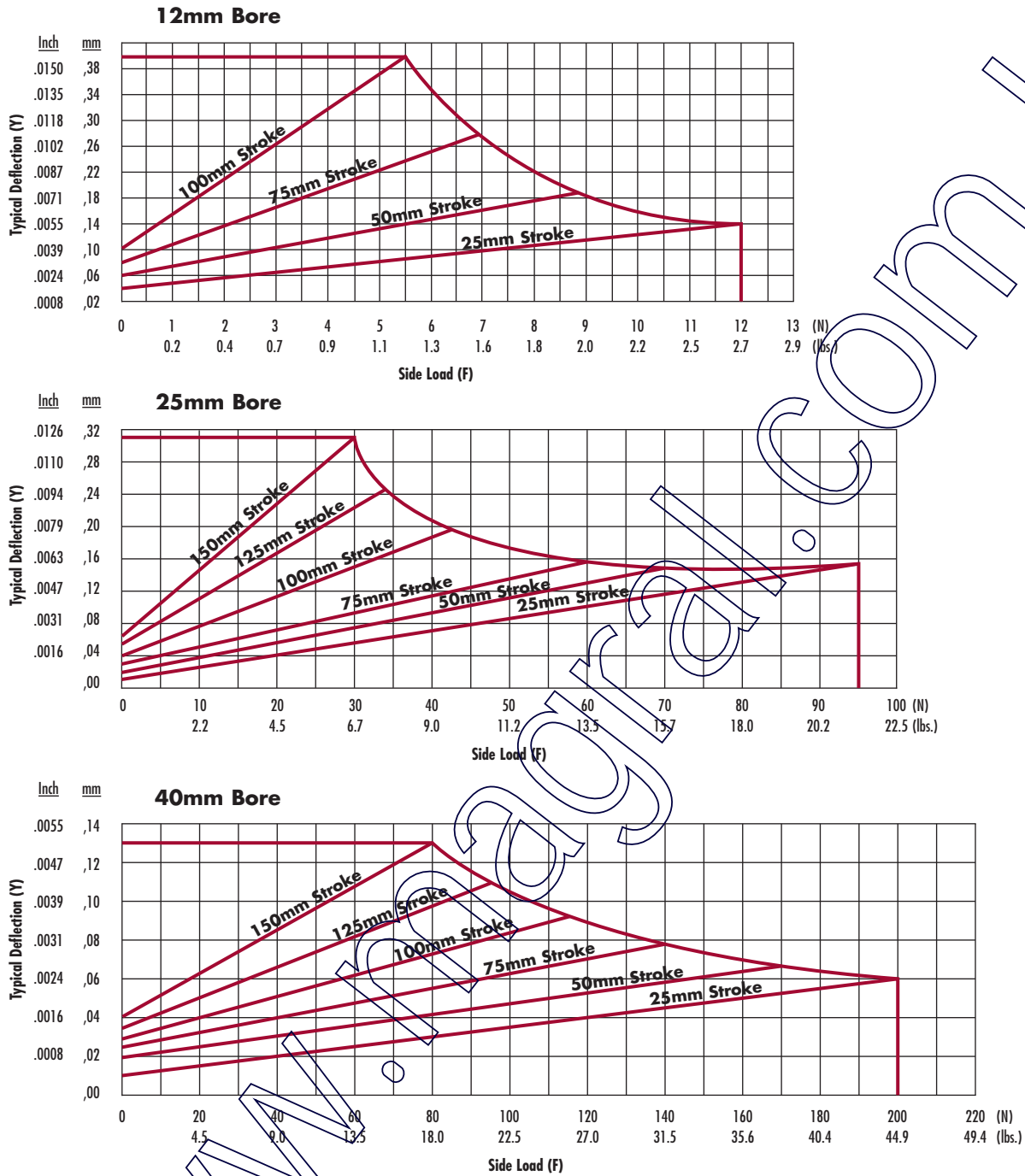

GC3000 / GC4000 Series Moment Ratings

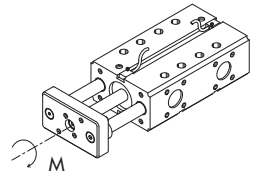
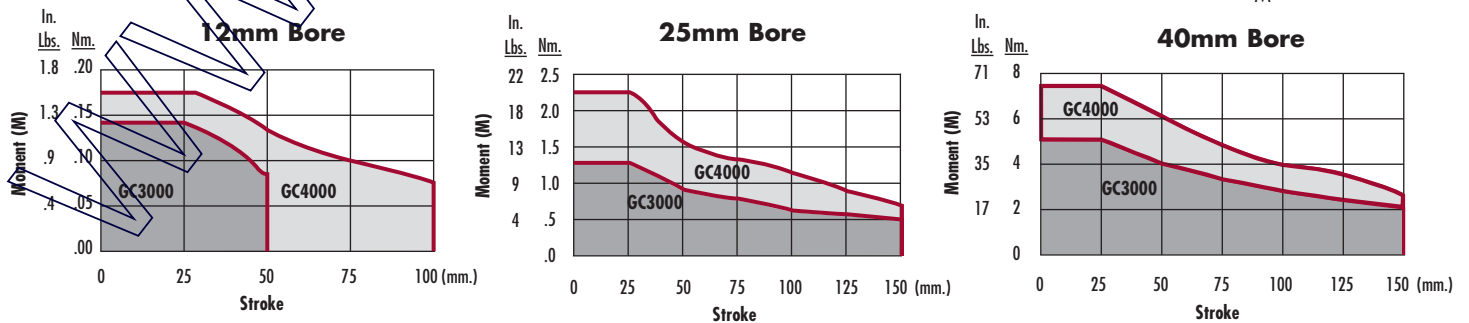

GC3000 & 4000 Series Guided Cylinder Application Examples

Examples

- 1.) Load on the thin side
- 2.) Offset loads
- 3.) Combined bending and moment loads
- 4.) Stopping a moving mass
- 5.) Mass dropped from a height

1.) Load on the thin side

The maximum side load (F) is still limited by the charts on pages 25 and 26.

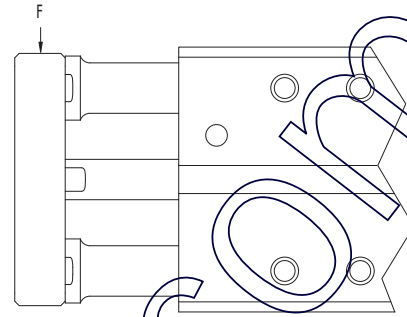

2.) Offset loads

Add the offset distance "ℓ" to the stroke and apply the appropriate chart from pages 25 and 26.

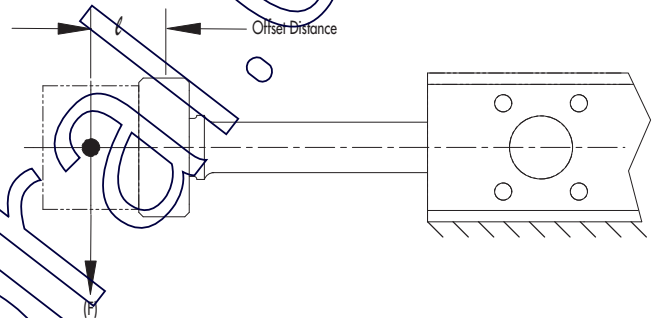

3.) Combined bending and moment loads

- 1.) Apply the appropriate side load chart from pages 25 and 26.
- 2.) Determine the ratio of applied side load "F" to the maximum allowable load.
- 3.) Using the moment rating chart, calculate the ratio of applied moment (F • ℓ) to allowable moment.
- 4.) Check to ensure that the sum of these ratios is less than 1.

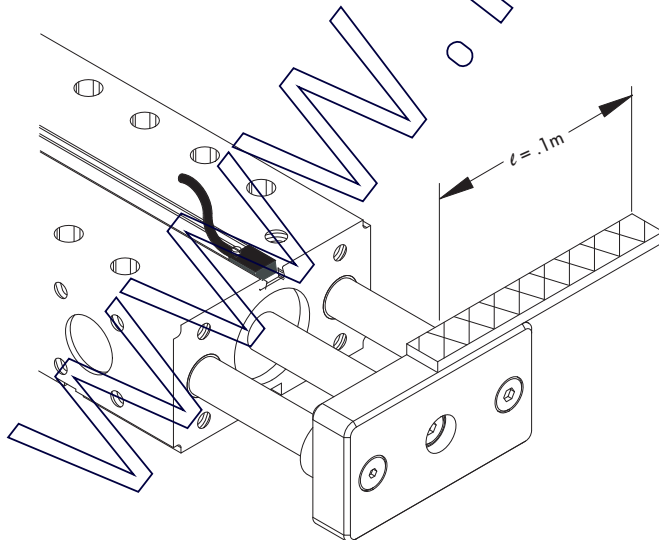

Example: GC440x100 loaded as shown

$$\begin{aligned} \text{Side load } F &= 25\text{N} \\ \text{Moment load } M &= F \cdot \ell \\ &= 2,5\text{Nm} \end{aligned}$$

From charts on page 25, for 100mm stroke, the maximum allowable side load = 117N

$$\text{Ratio of side loads} = \frac{25}{117} = .21$$

From the moment rating chart for GC440x100, the maximum allowable moment = 4,1Nm

$$\text{Ratio of moments} = \frac{2,5}{4,1} = .61$$

✓ Design check: Moment ratio + side load ratio < 1
 $.61 + .21 < 1$
 $.82 < 1$ Therefore safe

GC3000 & 4000 Side Load Capacities and Moment Ratings

4.) Stopping a moving mass

The maximum allowable mass (m) is given by the following formulas:

$$\text{Strokes over 25mm: } m = \frac{k_1}{s^3 v^2}$$

$$\text{Strokes 25mm and below: } m = \frac{(6.4 \times 10^{-5}) k_1}{v^2}$$

Where:

m = moving mass (kg)

v = velocity of the mass (m/min.)

s = actuator stroke (mm)

k₁ = See table below

k ₁			
Style	12mm	25mm	40mm
GC3000	1.4x10 ⁶	11x10 ⁶	2.5x10 ⁸
GC4000	3.9x10 ⁶	39x10 ⁶	8x10 ⁸

NOTE: Ensure that the resultant side load at rest = mass (kg) x 9.81 x μ, does not exceed the ratings shown on pages 25 and 26.

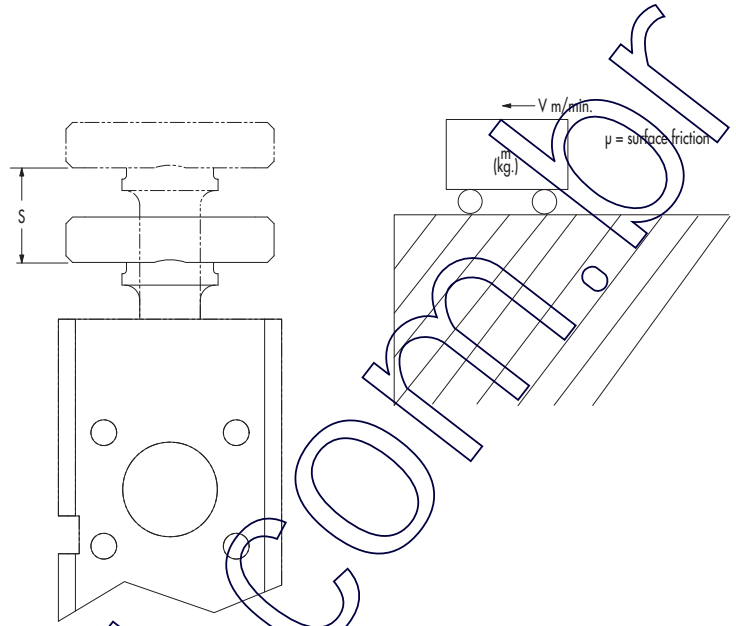

5.) Mass dropped from a height

The maximum allowable mass (m) that can be dropped on the actuator is given by the following formulas:

$$\text{Strokes over 25mm: } m = \frac{k_2}{s^3 h}$$

$$\text{Strokes 25mm and below: } m = \frac{(6.4 \times 10^{-3}) k_2}{h}$$

Where:

m = falling mass (kg)

h = falling height (mm)

s = actuator stroke (mm)

k₂ = See table below

k ₂			
Style	12mm	25mm	40mm
GC3000	20x10 ³	158x10 ³	350x10 ⁴
GC4000	55x10 ³	557x10 ³	110x10 ⁵

NOTE: Ensure that the weight = mass calculate (kg) x 9.81 does not exceed the side load rating shown on pages 25 and 26.

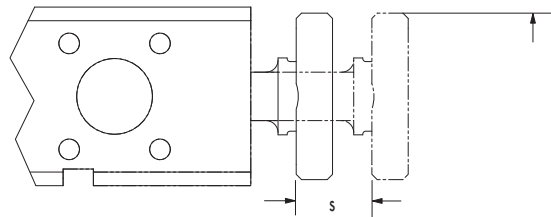
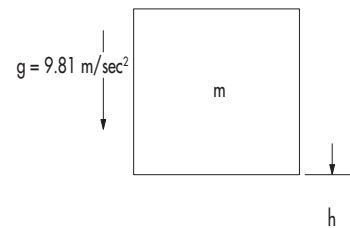

Sensors

Standard Limit Sensors

- Low Cost and compact size
- Dual LED indicators for power and signal
- Circuit protection for surge and polarity
- High-flex robotic grade cable with 4,8mm (3/16") bend radius. 105 strand primaries.
- CE compliant / IP67 and NEMA 6P rated
- 100% solid state device for maximum life
- 3 cord options

(Shown with Quick Disconnect Option)



3 Prong Plug

#WSKLP, #WSCLP, #WSKLP3, #WSCLP3

Part No.	Sensor Type (Wiring diagrams and definitions on page 5)	Cord Types		
		Quick Disconnect	1 Meter	3 Meter
Sinking	NPN		✓	
		✓*		
				✓
		✓*		
Sourcing	PNP		✓	
		✓*		
				✓
		✓*		

*NOTE: Mating 3 socket receptacle available, part # R3.

WS_LP

WS_LPS

Optional Quick Disconnect Sensor Cable with threaded, sealed connectors

Part Number - Specify **K** or **C**

Plug - 3 Prong

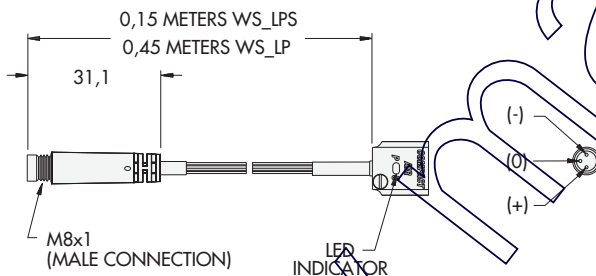

3 Socket Mating Cable

For use with:

#WSKLP, #WSCLP, #WSKLP3, #WSCLP3,



Sold Separately

Part Number

R3

Receptacle - 3 Socket

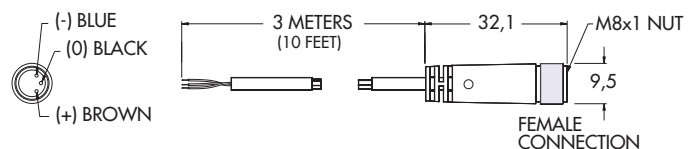

Sensors

Comtronic® Sensors Dimensional Information

Must specify 'K' (sinking) or 'C' (sourcing) when ordering

Part Number - Specify K or C

WS_L WS_L-3

"3" denotes 3 meter cable

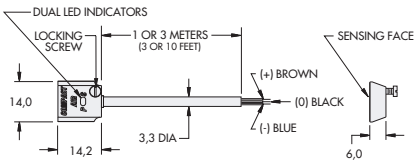

Part No. **WSKL-3** - Sinking output with 3 meter cable.



Specifications	
Parameters	Compact® Standard Limit Sensors
	NPN (sinking) PNP (sourcing)
Part Number	WSKL, WSKL3, WSKLP, WSKLPS WSCL, WSCL3, WSCLP, WSCLPS
Operating Voltage	5-24 VDC
Current Consumption	
On	16mA (at 24V) 14mA (at 24V)
Off	7mA (at 24V) 7mA (at 24V)
Switching Current	100mA Max
Voltage Drop	1.5 V Max @ 100mA
Operating Frequency	1 KHz Max
Switch Logic	Sinking, Normally Open Sourcing, Normally Open
LED Function	
Green	Power On
Red	Switch Active (Magnet Present)
Operating Temperature	0°C to 70°C
Circuit Protection	Reverse Polarity / Surge Absorber
Environmental Certifications	IEC standard IP67, NEMA 6P
Wire Type	High flex, 24 AWG / 105 strand primary
Housing Material	Zinc diecast
Housing Color Code	Black Silver
Shock Resistance	30G Max
Vibration Strength	9G Max

Wiring Diagrams and Definitions

For units with flying leads

NPN Output Sinking (K)

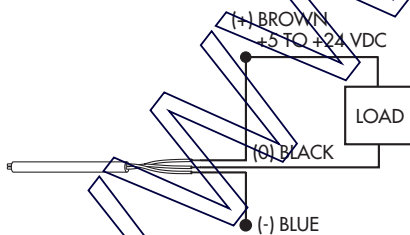

- Ideal for complex controls utilizing multiple power supplies.

A "sinking" output sensor complete a circuit by connecting the load to ground. Sinking output sensors in a sequence can have different supply voltages. The ground is their common factor.

PNP Output Sourcing (C)

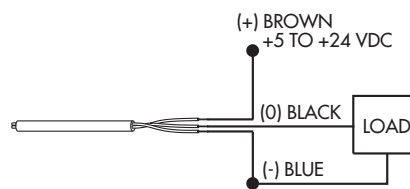

- Ideal for single power supply applications.

A "sourcing" output sensor completes a circuit by connecting the load to the supply current. All sourcing output sensors must have the same supply voltage.

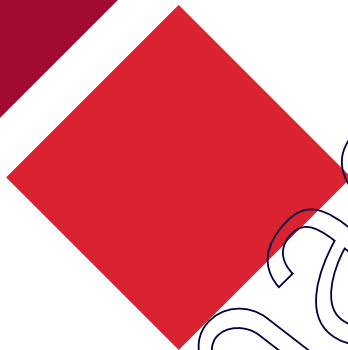
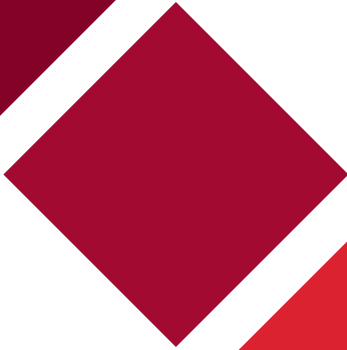

COMPACT[®]
AUTOMATION PRODUCTS

Compact Automation Products, LLC
105 Commerce Way
Westminster, SC 29693
Tel: 864.647.9571
Fax: 864.647.9574
www.compactautomation.com

CAP854R3

An ITT Company

11/20

www.magral.com.br