

COMPACT[®]
AUTOMATION PRODUCTS

Guided Slides and Guided Rods

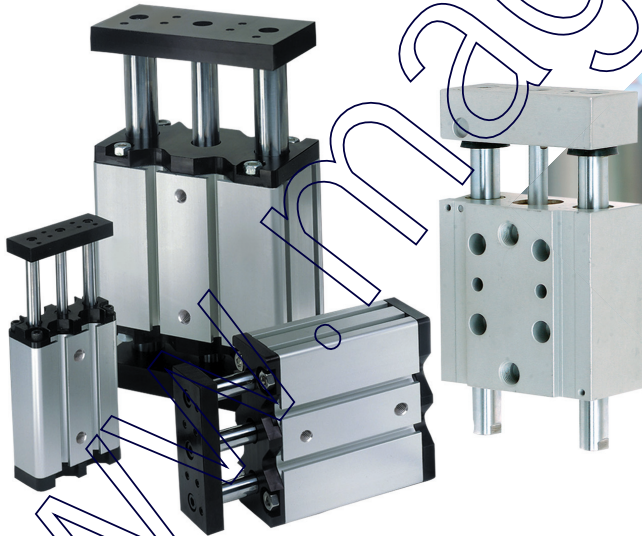

Guided Slides & Guided Rods: Table of Contents

Guided Slides & Guided Rods

Guided Slides

Product Features	pg 2
Quick Reference.....	pg 2
How to Order	pg 3
Dimensional Data	pg 4

Engineering Data

GS Series	pg 5
Deflection vs. Load	pg 7
Design Consideration	pg 9
Sensor Specifications/Solid State Specifications	pg 12

Guided Rods

Product Features	pg 14
How to Order	pg 15
Options & Mounting.....	pg 16
Dimensional Data	pg 17
Deflection & Force.....	pg 18
Sensor.....	pg 18

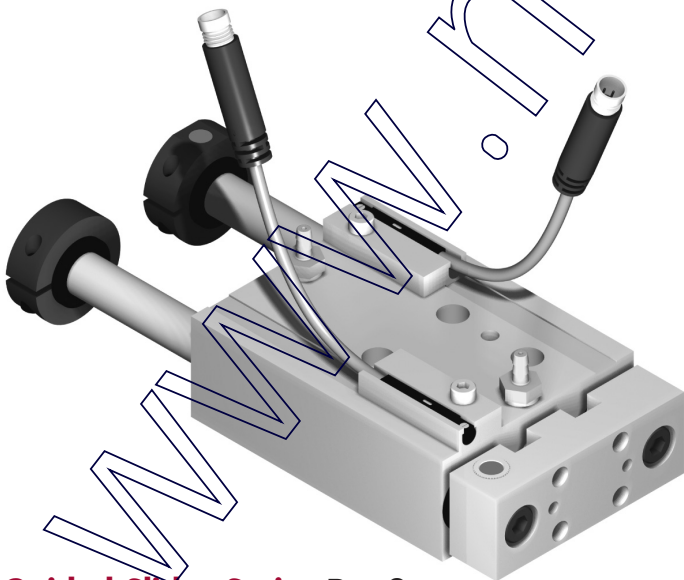

Guided Slides Series Pg. 2



Guided Rod Series Pg. 14

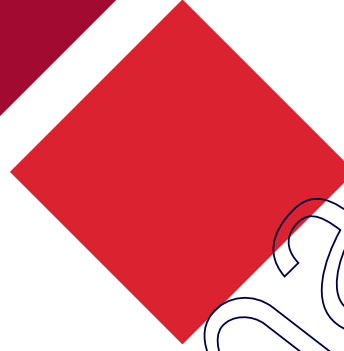

COMPACT[®]
AUTOMATION PRODUCTS

Compact Automation Products, LLC
105 Commerce Way
Westminster, SC 29693
Tel: 864.647.9521
Fax: 864.647.9574
www.compactautomation.com

www.magral.com.br

GS Series: Product Features

GUIDED SLIDES:

- Slim, Compact design
- High load capacity, long life
- 5 bore sizes
- Stroke lengths up to 75mm (3")
- Longer strokes available upon request
- Imperial and metric mounting styles
- Self-lubricating composite bearings
- External urethane pads (retract stroke)
- Internal urethane cushions (extend stroke), standard on 20mm and 32mm bores
- Close fit dowel pin holes, standard on all bores
- Competitively priced
- Wide range of applications
- Accessories include:
 - Adjustable stroke collars and pads
 - Sensor ready kits

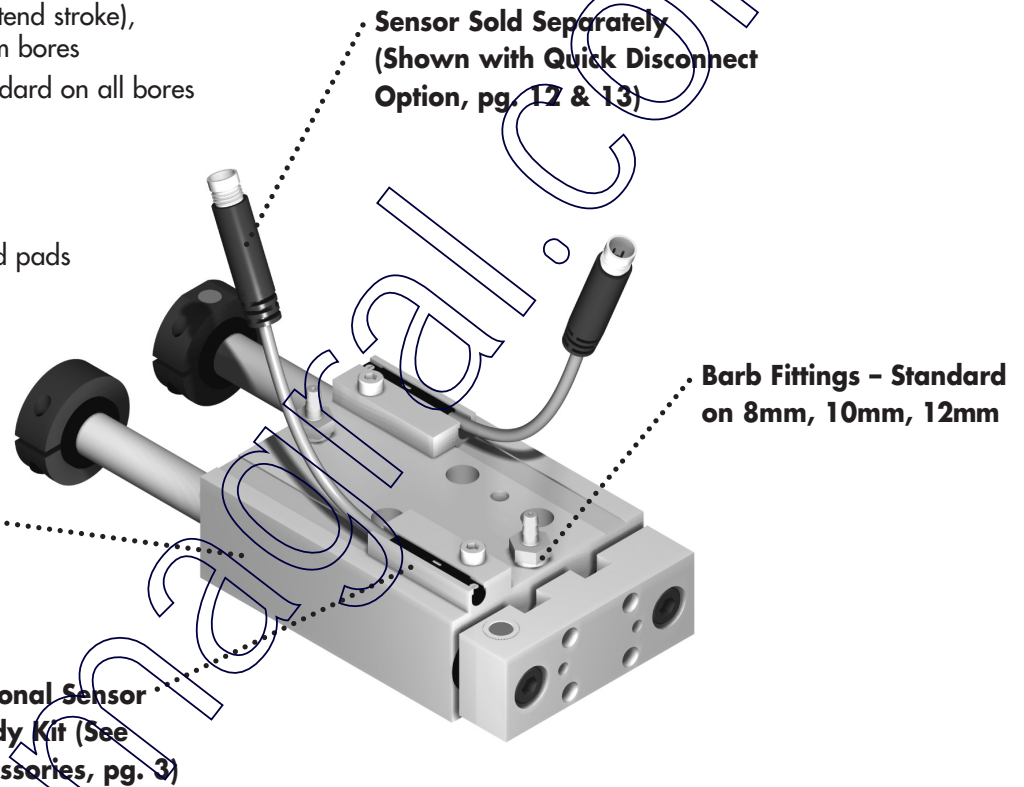

Quick Reference

Series	Bore		Shaft Diameter		Guide Rod Diameter		Effective Piston Area			
	mm	[inch]	mm	[inch]	mm	[inch]	Extend		Retract	
							mm ²	[inch ²]	mm ²	[inch ²]
GS_8	8	[0.315]	4	[0.157]	6	[0.236]	50,27	[0.078]	37,70	[0.058]
GS_10	10	[0.394]	5	[0.197]	6	[0.236]	78,54	[0.122]	58,90	[0.091]
GS_12	12	[0.472]	6	[0.236]	10	[0.394]	113,10	[0.175]	84,82	[0.131]
GS_20	20	[0.787]	8	[0.315]	12	[0.472]	314,16	[0.487]	263,89	[0.409]
GS_32	32	[1.260]	12	[0.472]	20	[0.787]	804,25	[1.247]	691,15	[1.071]

How to Order: GS Series Slides

SERIES	MOUNTING STYLE	BORE	X	MOUNTING PATTERN	STROKE LENGTH	OPTIONS
GS	T	20	X	I	2	J2
1	2	3		4	5	6

1 Series	
GS	Guided Slide

2 Mounting Style	
S	Standard
T	Transition

3 Bore	
8	8 Millimeter
10	10 Millimeter
12	12 Millimeter
20	20 Millimeter
32	32 Millimeter

4 Mounting Pattern	
I	Imperial
M	Metric

5 Stroke Lengths				
Bore Size (millimeter)	Imperial Strokes (Mounting Pattern must be Imperial)		Metric Strokes (Mounting Pattern must be Metric)	
	Description	Stroke	Code	Stroke Code
8, 10, 12	1/2"	12	12mm	12
8, 10, 12, 20, 32	1"	1	25mm	25
8, 10, 12	1-1/2"	112	40mm	40
20, 32	2"	2	50mm	50
20, 32	3"	3	75mm	75

6 Options	
J2	Dowel Pin holes in Tooling Plate - Normal Fit <i>(Imperial only)</i>
R2	Dowel Pin holes in Body - Normal Fit <i>(Imperial only)</i>
Q6	Corrosion Resistant Coating - Guide Rods

NOTE: Close fit dowel pin holes in tooling plate and body are standard.

Accessories (Sold Separately)		
Description	Bore Size	Part No.
Adjustable Stroke Collars and Pads <small>Note: All collars supplied with hex key wrench</small>	8mm	W8ADJE
	10mm	W10ADJE
	12mm	W12ADJE
	20mm	W20ADJE
	32mm	W32ADJE
Sensor Ready Kit: (2) Socket head cap screws (2) Sensor mounting brackets (1) Tooling plate magnet (2) Shaft collars (1 mag. & 1 non-mag.) (2) Urethane pads	8mm	W8SK
	10mm	W10SK
	12mm	W12SK
	20mm	W20SK
	32mm	W32SK

Dimensional Data – GS Series

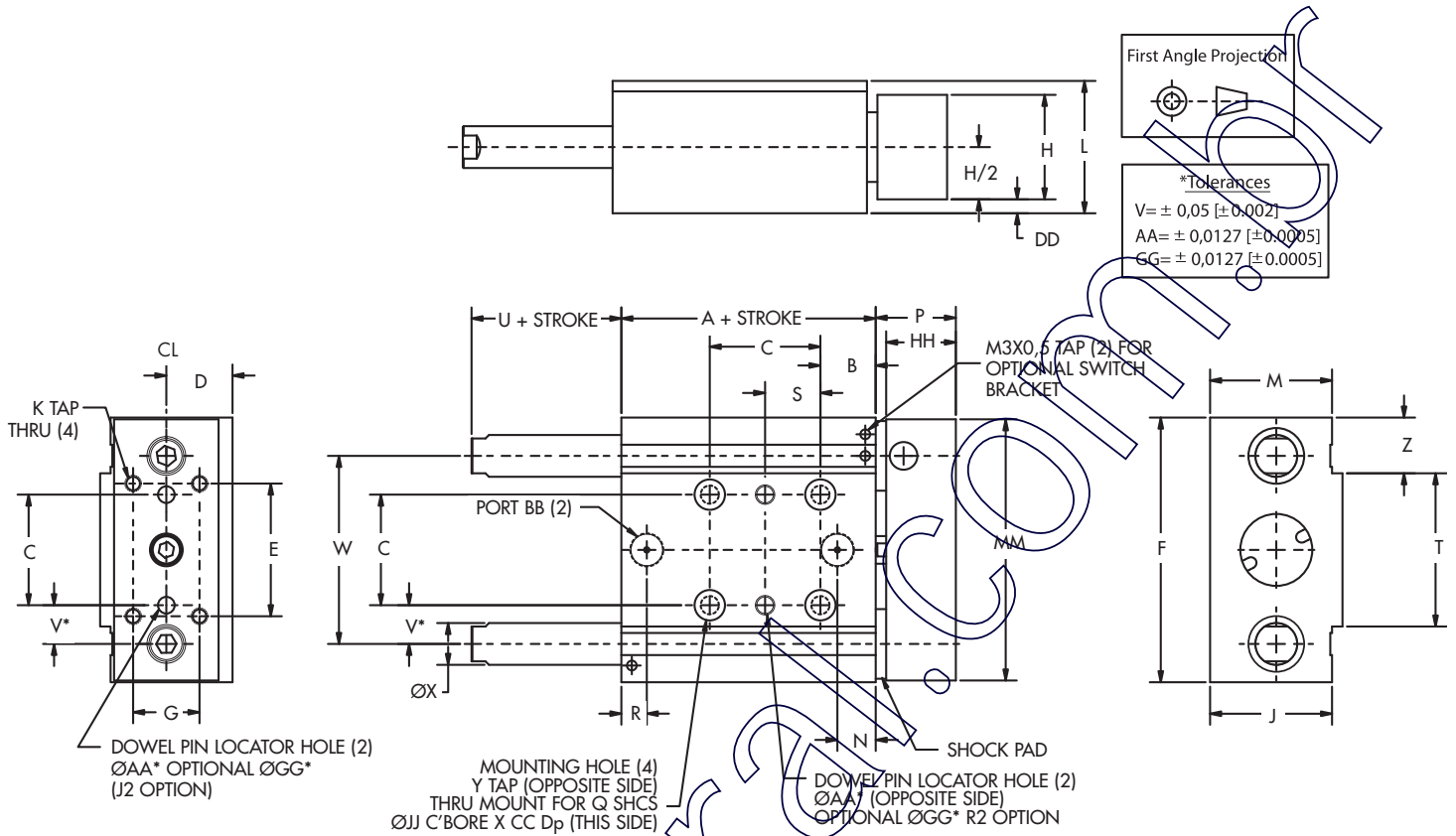

Dimensional Specifications GS Series Slide

	Bore	A	B	C	D	E	F	G	H	J	K	L	M	N	P	Q	R	S	T	U	V*	W	X	Y	Z
I (Imperial mounting pattern)	8	30	[.562]	[.562]	[.276]	[.625]	36	[.25]	12	-	[3-48]	14	-	6	11.5	#[2]	5.25	[.281]	-	12	[.231]	26	6	[4-40x.25Dp]	-
	10	30	[.562]	[.625]	[.394]	[.75]	44	[.375]	16	-	[4-40]	21	-	11.5	11.5	#[4]	6.5	[.312]	-	12	[.278]	30	6	[6-32x.375Dp]	-
	12	35	[.562]	[.875]	[.512]	[1]	57	[.5]	21	-	[6-32]	26	-	13	15.5	#[6]	5.2	[.438]	-	14.5	[.370]	41	10	[10-24x.5Dp]	-
	20	48	[.625]	[1.25]	[.748]	[1.5]	76	[.75]	30	35	[10-24]	38	35	11	23	#[10]	7.3	[.625]	44	18	[.438]	54	12	[1/4-20x.625Dp]	16
	32	54	[.812]	[1.688]	[.984]	[2]	100	[1]	44	46.5	[1/4-20]	49.5	48.5	14	31	[1/4]	10	[.844]	66	22	[.593]	73	20	[5/16-18x.875Dp]	18
M (Metric mounting pattern)	8	30	14	14	7	16	36	8	12	-	M2,5x0,45	14	-	6	11,5	M2	5,25	7	-	12	6	26	6	M3x0,5x8Dp	-
	10	30	14	16	10	20	44	10	16	-	M3x0,5	21	-	11,5	11,5	M3	6,5	8	-	12	7	30	6	M4x0,7x10Dp	-
	12	35	14	22	13	26	57	14	21	-	M4x0,7	26	-	13	15,5	M4	5,2	11	-	14,5	9,5	41	10	M5x0,8x12,5Dp	-
	20	48	18	30	19	40	76	20	30	35	M5x0,8	38	35	11	23	M5	7,3	15	44	18	12	54	12	M6x1x16Dp	16
	32	54	22	42	25	52	100	29	44	46,5	M6x1	49,5	48,5	14	31	M6	10	21	66	22	15,5	73	20	M8x1,25x20Dp	18

Dimensional Specifications GS Series Slide

	Bore	AA*	BB	CC	DD	EE	FF	GG*	HH	JJ	MM
I (Imperial mounting pattern)	8	[.0634]	[3-56 w/barb fitting]	[.28]	1	#[3]	[.375]	[.0645]	10	[.20]	35
	10	[.0747]	[10-32 w/barb fitting]	[.31]	2	#[4]	[.5]	[.0958]	10	[.24]	43
	12	[.1259]	[10-32 w/barb fitting]	[.25]	2.5	#[6]	[.75]	[.1270]	14	[.30]	56
	20	[.1884]	[1/8-27NPT]	[.35]	4	#[10]	[1]	[.1895]	20	[.34]	75
	32	[.2509]	[1/8-27NPT]	[.43]	3	[1/4]	[1.5]	[.2520]	26	[.44]	99
M (Metric mounting pattern)	8	2	M3x0,5 w/barb fitting	6	1	M2	10	-	10	5	35
	10	2,5	M5x0,8 w/barb fitting	7	2	M3	10	-	10	6	43
	12	3	M5x0,8 w/barb fitting	6	2,5	M4	18	-	14	7,5	56
	20	4	G1/8BSP	10	4	M5	24	-	20	9,5	75
	32	6	G1/8BSP	11	3	M6	38	-	26	11,1	99

GST Series

T - Mounting Style

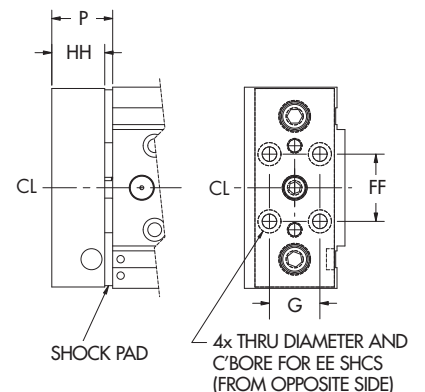

*NOTE: See Tolerance Box.

Engineering Data – GS Series

Cylinder Weight KG [lb]

Cylinder Weight KG [lb]										
Series	Stroke mm [inch]									
	12	[1/2]	25	[1]	40	[1-1/2]	50	[2]	75	[3]
GS_8	0,86	[0.19]	1,13	[0.26]	1,41	[0.32]	-	-	-	-
GS_10	1,37	[0.31]	1,80	[0.41]	2,23	[0.50]	-	-	-	-
GS_12	2,92	[0.66]	3,42	[0.77]	3,89	[0.88]	-	-	-	-
GS_20	-	-	7,28	[1.64]	-	-	9,87	[2.22]	12,45	[2.80]
GS_32	-	-	15,54	[3.49]	-	-	21,26	[4.78]	27,02	[6.07]

Maximum Static Loads

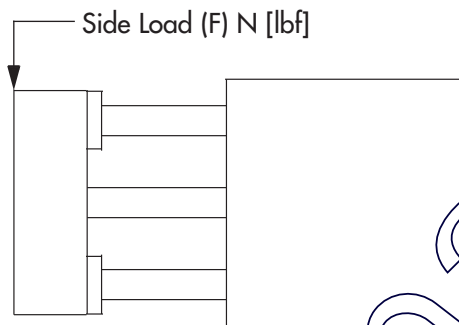
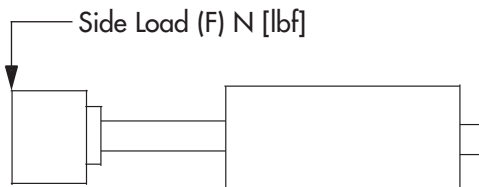

Maximum Static Side Loads				
Series	Stroke Max.		Side Loads	
	mm	[inch]	N	[lbf]
GS_8	12	[0.5]	180	[40.5]
	25	[1]	133	[29.9]
	40	[1.5]	110	[24.7]
GS_10	12	[0.5]	410	[92.2]
	25	[1]	290	[65.2]
	40	[1.5]	230	[51.7]
GS_12	12	[0.5]	950	[213.6]
	25	[1]	700	[157.4]
	40	[1.5]	560	[125.9]
GS_20	25	[1]	1580	[355.2]
	50	[2]	1080	[242.8]
	75	[3]	820	[184.3]
GS_32	25	[1]	4350	[977.9]
	50	[2]	2600	[584.5]
	75	[3]	2250	[505.8]

Breakaway

The chart to the right contains formulas for the approximate breakaway pressure for the GS Series based on the load applied at the tooling plate as shown.

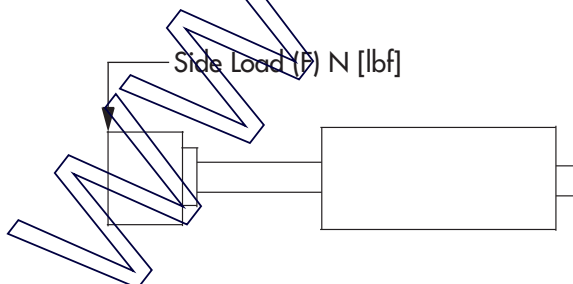

Series	Maximum Breakaway Pressure	
	bar	psi
GS_8	$(F \times 0,136) + 1,38$	$(F \times 8.9) + 20$
GS_10	$(F \times 0,127) + 1,38$	$(F \times 8.3) + 20$
GS_12	$(F \times 0,091) + 1,38$	$(F \times 6.0) + 20$
GS_20	$(F \times 0,017) + 1,38$	$(F \times 1.2) + 20$
GS_32	$(F \times 0,006) + 1,38$	$(F \times 0.4) + 20$

Operating Pressures

- GS Slides are rated for pneumatic use only.
- Maximum operating pressure is 10,3 bar [150 psi].
- Minimum operating pressure is 1,4 bar [20 psi].

Seals

- Guided Slides utilize low friction Nitrile seals for low breakaway and long life.
- Alternative seal materials are available to meet special application needs.

Operating Temperatures

- Normal operating temperature range is from -20 degrees to 80 degrees Celsius [-4° to 176° F].
- For temperatures outside this range, consult the factory.

Stroke Tolerance

- Tolerance of nominal stroke is +2/-0 mm [+0.08/-0 in].

Lubrication

- Guided Slides are lubricated at the factory for service under normal operating conditions.
- Lubricated air that is compatible with petroleum based grease containing Teflon® will enhance the life of the cylinder. Non-Lubricated air is acceptable to operate the cylinder.
- The guide rod composite bearings are lubricated with light oil. Periodic relubrication will enhance the life of the bearings. Silicon based lubricants are NOT compatible with the composite bearings and are not recommended for use.

Engineering Data – Deflection vs. Load

Off-Set Load

GS Slide performance data is based on a force acting at the face of the tooling plate. For a load attached to the front of the tooling plate, the formula and chart to the right is to be used to calculate the off-set load that is being applied to the cylinder. This off-set load must be used when considering all load based performance.

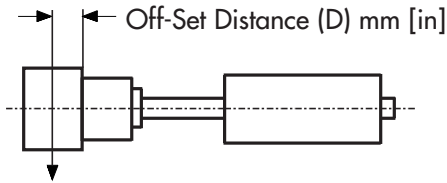

Load Weight (W) N [lbf]

Formula: Off-Set Load (F) N [lbf] = W + (K x W x D)

Maximum Static Side Loads				
Series	Stroke		Constant (K)	
	mm	[inch]	mm	[inch]
GS_8	12	[0.5]	0,042	[1.067]
	25	[1]	0,027	[0.696]
GS_10	40	[1.5]	0,020	[0.516]
	12	[0.5]	0,037	[0.942]
GS_12	25	[1]	0,025	[0.640]
	40	[1.5]	0,019	[0.485]
	25	[1]	0,021	[0.533]
GS_20	50	[2]	0,014	[0.348]
	75	[3]	0,010	[0.258]
GS_32	25	[1]	0,018	[0.457]
	50	[2]	0,012	[0.314]
	75	[3]	0,009	[0.239]

8mm Bore

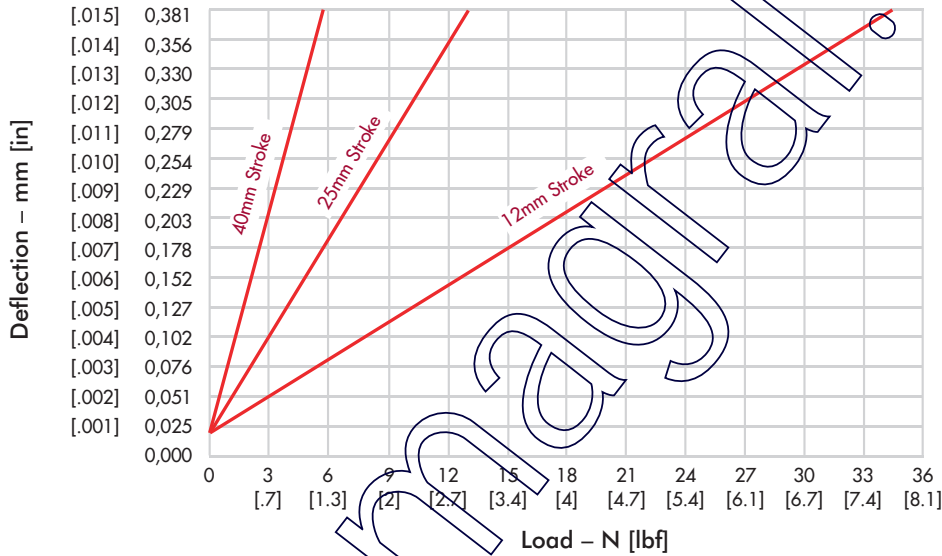

10mm Bore

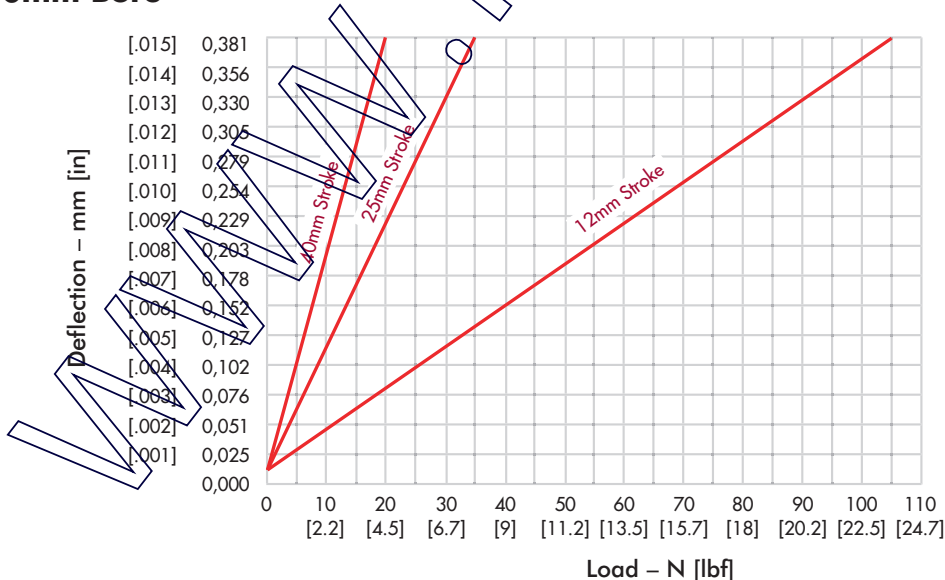

Engineering Data – Deflection vs. Load

12mm Bore

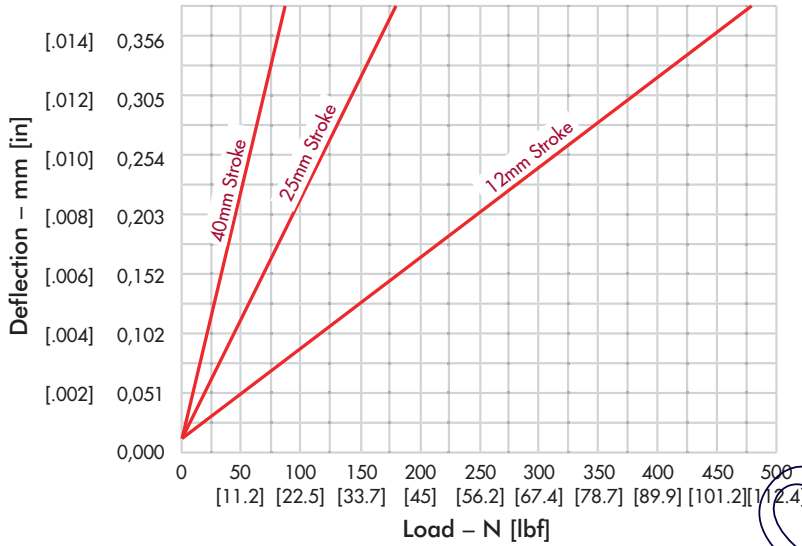

20mm Bore

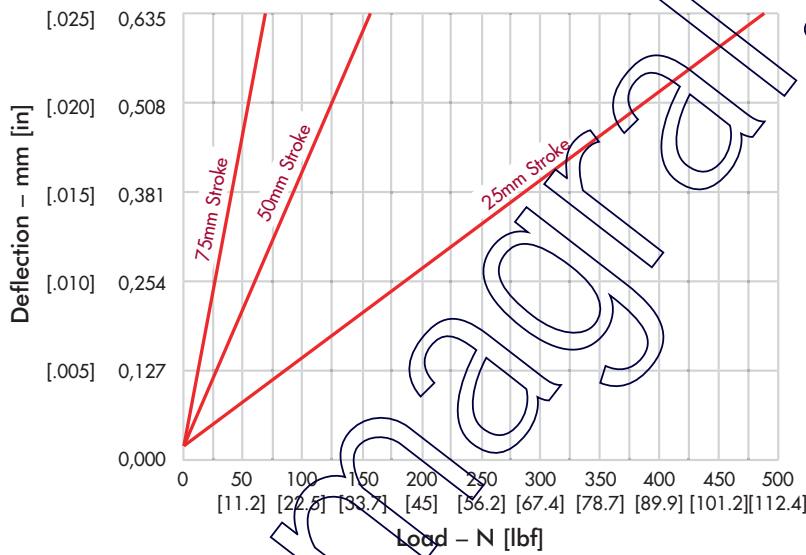

32mm Bore

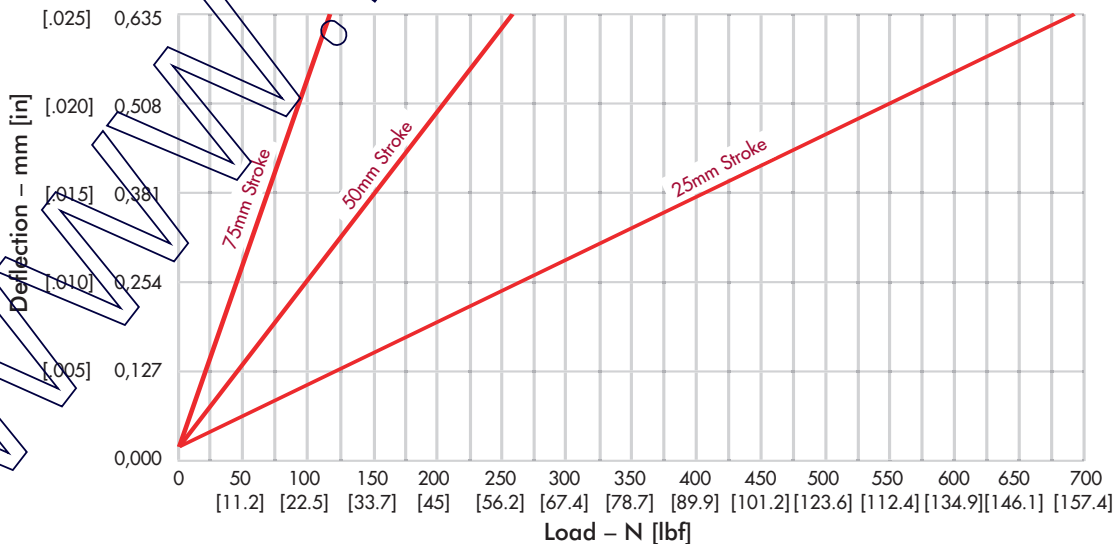

Engineering Data – Design Considerations

Design Suggestions:

Flow Controls

- Flow controls are strongly suggested on all GS Series Slides to control speed and increase life expectancy.

Adjustable Stroke Collars and Pads

- Optional adjustable stroke collars and pads increase load and speed capacity.

Kinetic Energy Guide

- Curves A & B represent the travel life expectancy for the GS cylinders.
- Curves C & D represent the maximum kinetic energy allowable for the specific cylinder configurations.
- For operating conditions represented by curves C & D that fall under either curve A or B, the cylinder can be expected to achieve indicated life of Curve A or B.
- Operating conditions greater than those represented by curves C & D for the stated cylinder configurations will require external load stops to accommodate the excessive kinetic energy.
- For operating conditions represented by curves C & D that fall above either curve A or B, the cylinder life will be substantially less than the indicated life of curve A or B.

8mm Bore Kinetic Energy

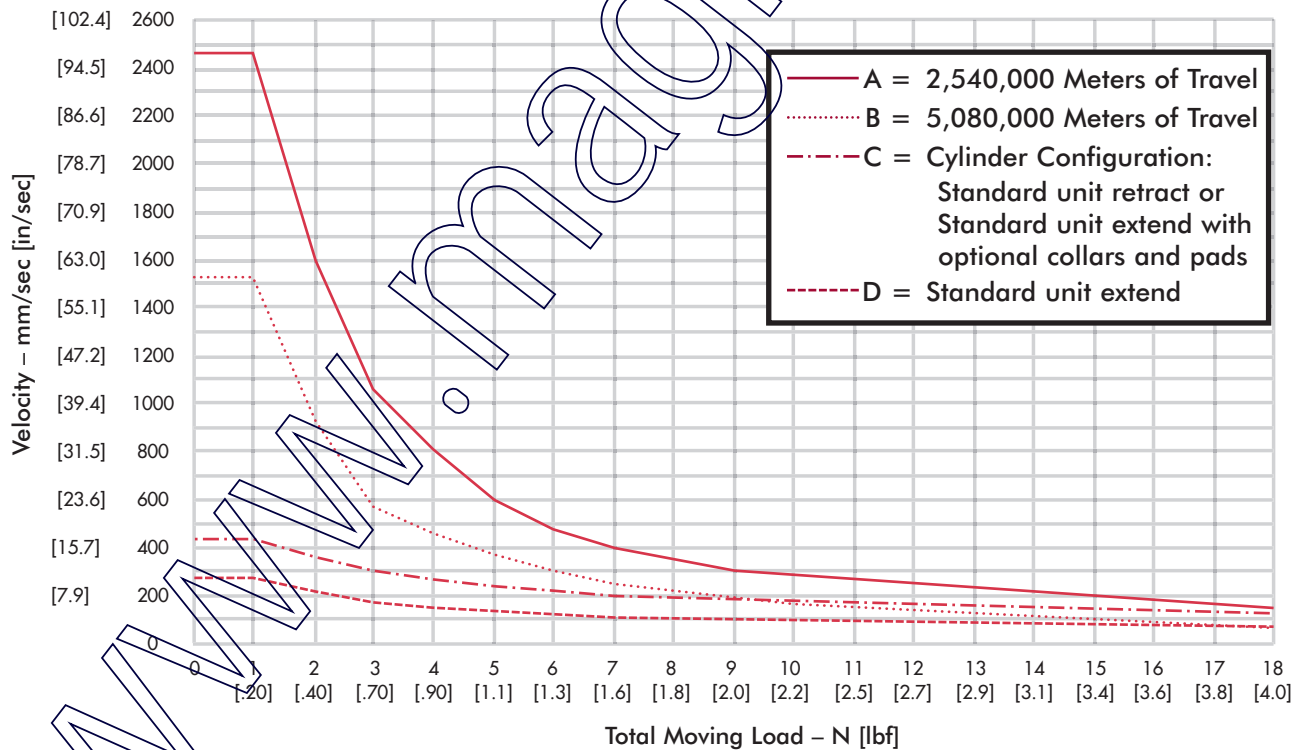

10mm Bore Kinetic Energy

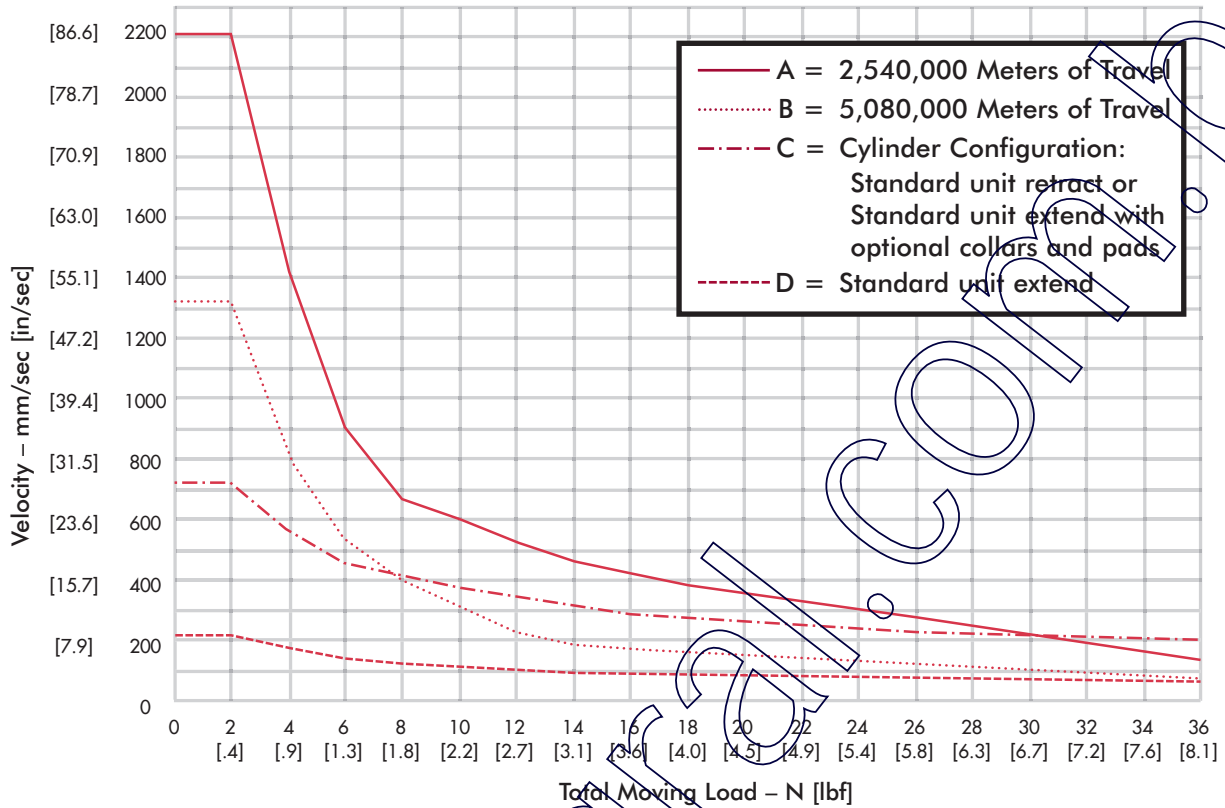

12mm Bore Kinetic Energy

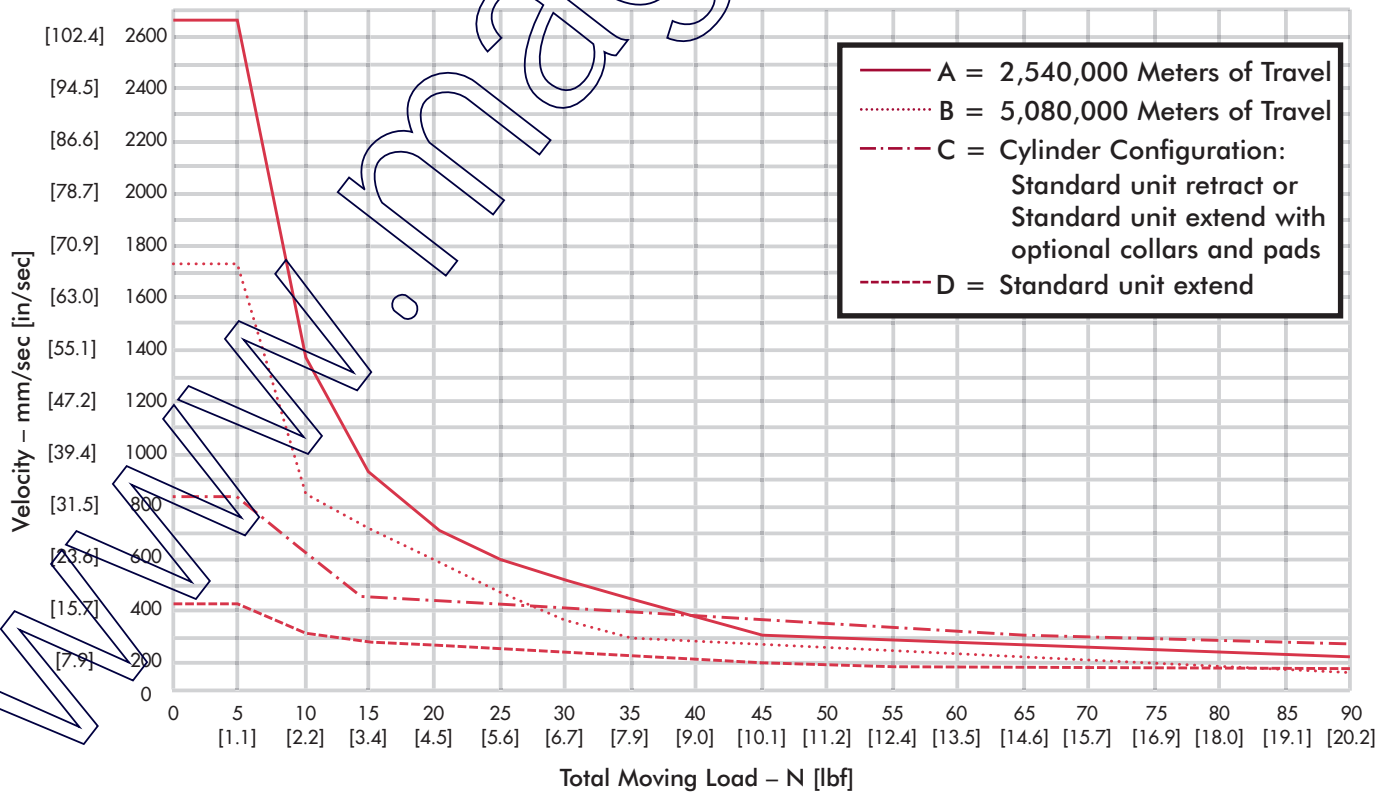

20mm Bore Kinetic Energy

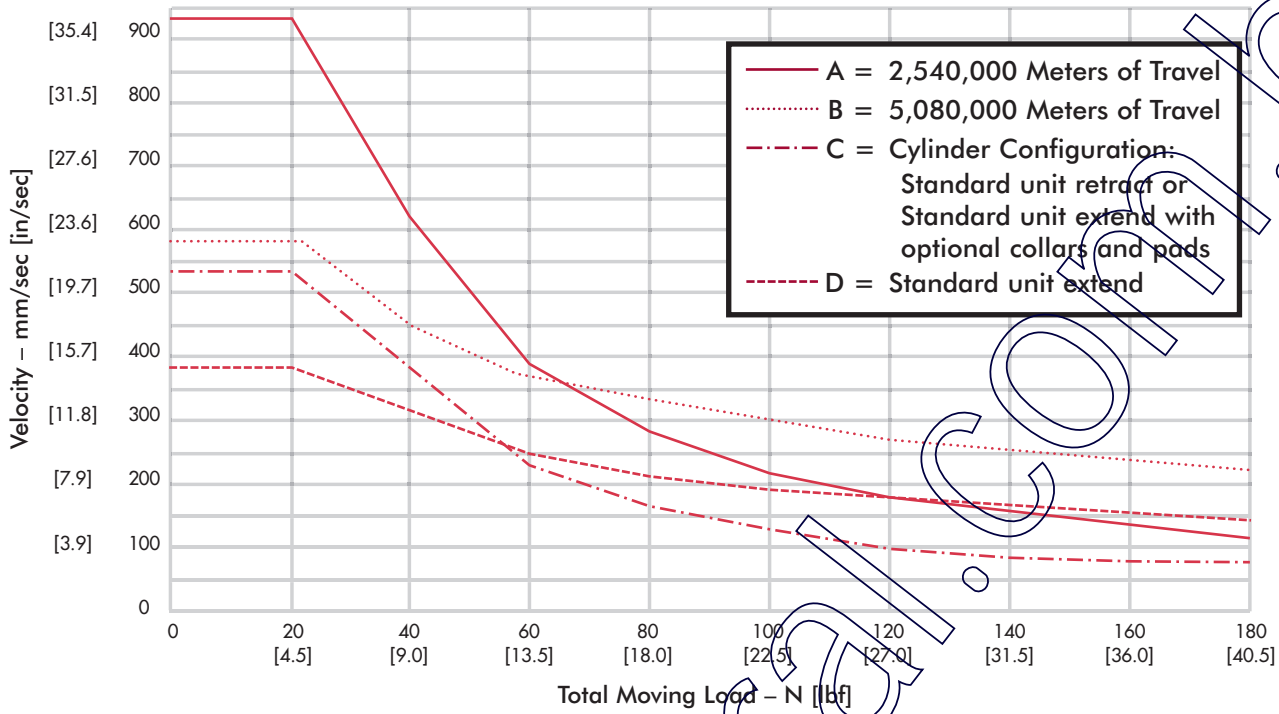

32mm Bore Kinetic Energy

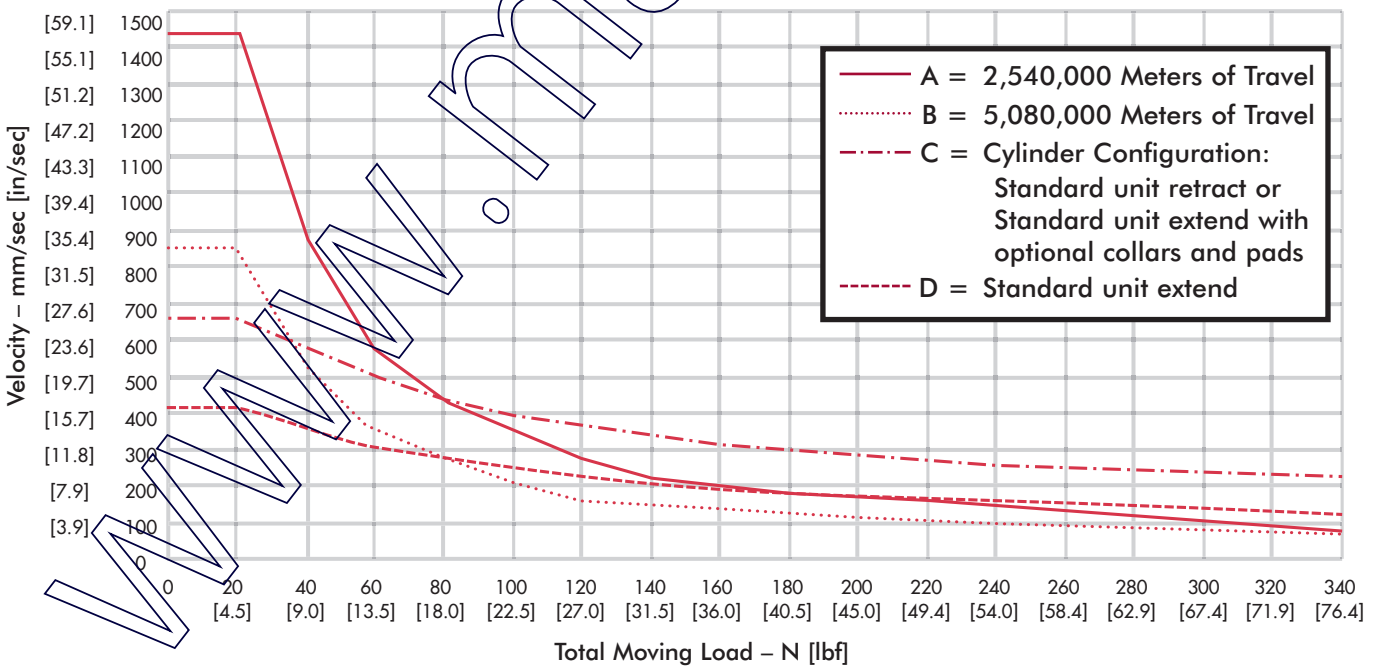

Sensor Specifications

Compact Round Series:

- Low cost and compact size.
- Single LED indicator for signal.
- Circuit protection (surge and polarity).
- High-flex robotic grade cable.
- CE compliant IP67 and NEMA 6 rated.



SHOWN WITH QUICK DISCONNECT OPTION

Part No.	Sensor Type	Cord Type		Lead	
		Quick Disconnect	1m	3m	3m
WSKLRPS	NPN (sinking)				
WSKLR	NPN (sinking)		✓		
WSKLR-3	NPN (sinking)				✓
WSCLRPS	PNP (sourcing)	✓			
WSCLR	PNP (sourcing)		✓		
WSCLR-3	PNP (sourcing)				✓
WRSPS	REED	✓			
WRS	REED		✓		
WRS-3	REED				✓

NOTE: PS denotes 1.50mm lead.
-3 denotes 3m flying lead.

NOTE: Cord set sold separately.

Dimensional Information:

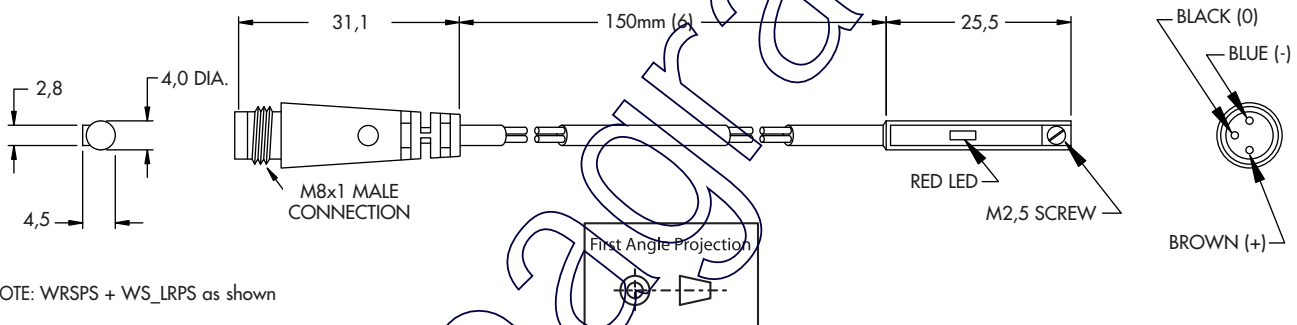

NOTE: WRSPS + WS_LRPS as shown

NOTE: All dimensions are in millimeters (inches).
WRS, WRS-3, WS_LR, WS_LR-3 have flying leads.

Solid State Sensor Specifications

Parameters	Compact Round Sensors	
	NPN (sinking)	PNP (sourcing)
Part Number	WSKLR_	WSCLR_
Operating Voltage	5-24 VDC	
Current Consumption	7 mA max @ 24V	9 mA max @ 24V
Switching Current	50 mA max	
Voltage Drop	0.5 V max @ 25 mA	1.2 V max @ 25 mA
Operating Frequency	1 KHz max	
Switch Logic	Sinking Normally Open	Sourcing Normally Open
LED Function	RED (Switch Active)	
Operating Temperature	-20° to 70° C	

Parameters	Compact Round Sensors	
	NPN (sinking)	PNP (sourcing)
Part Number	WSKLR_	WSCLR_
Circuit Protection	Surge Suppression, Reverse Polarity	
Environmental Certifications	IP67, NEMA 6	
Wire Type	Black Polyurethane Jacket, PVC Insulation	
Housing Material	Plastic	
Housing Color	Black	
Shock Resistance	50 G max	
Vibration Strength	9 G max	

Warning: Never Exceed Power Rating of 1.5 Watts (Watts = Volts x Amps)
or permanent damage to sensor will occur.

Wiring Diagrams and Definitions *for units with flying leads*

NPN OUTPUT Sinking (K)

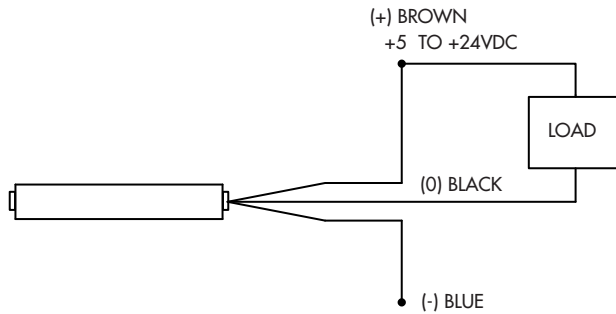

- Ideal for complex controls utilizing multiple power supplies.

A "sinking" output sensor completes a circuit by connecting the load to the ground. Sinking output sensors in a sequence can have different supply voltages. The ground is their common factor.

PNP OUTPUT Sourcing (C)

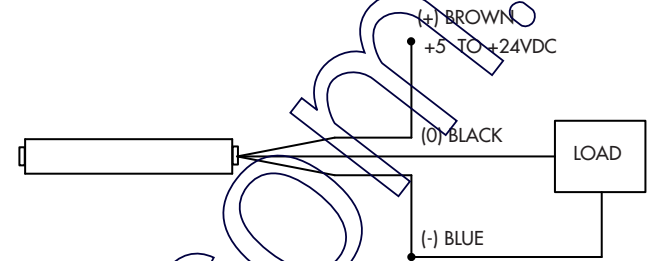

- Ideal for single power supply applications.

A "sourcing" output sensor completes a circuit by connecting the load to the supply current. All sourcing output sensors must have the same supply voltage.

Reed Sensor Specifications

Parameters	Compact Round Sensors
	Reed Switch
Part Number	WRS_
Operating Voltage	5-120 V DC/AC 50/60 Hz
Switching Current	50 mA max (Resistive)
Voltage Drop	2.5 V max
Operating Frequency	200 Hz max
Switch Logic	SPST Normally Open
LED Indicator	Red
Circuit Protection	None
Environmental Certifications	IP67, NEMA6
Cable	Black/Grey
Magnet Requirement	50 Gauss Parallel
Temperature Range	14° to 158° F (-10° to +70° C)
Shock / Vibration	30 G / 9 G
Power Rating*	6 Watts

* **Warning:** Never Exceed Rating (Watts = Volts x Amps) or permanent damage to sensor will occur.

Schematic and Wiring Diagram

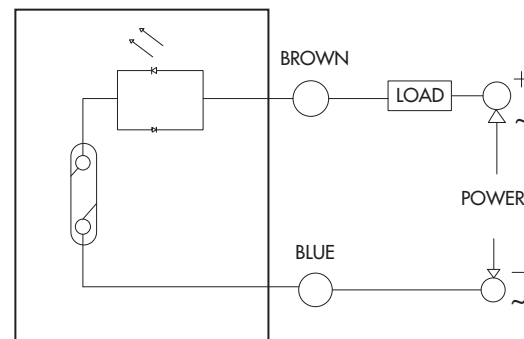

GR Series: Product Features

Guided Rod Cylinder combines high strength with light weight and can be customized to fit your specific needs. Our exclusive Enersorb™ piston is self-lubricating, up to 50% quieter than regular pistons and provides unparalleled repeatable stroke.

Standard Options

- Stop Collars
- Magnetic Piston for sensors
- Bridge Plate
- Clean Room Option (Consult factory)

Temperature Range -20°F to 180°F.
Consult factory for higher temperature.
Rated Pressure 150 PSIG Air

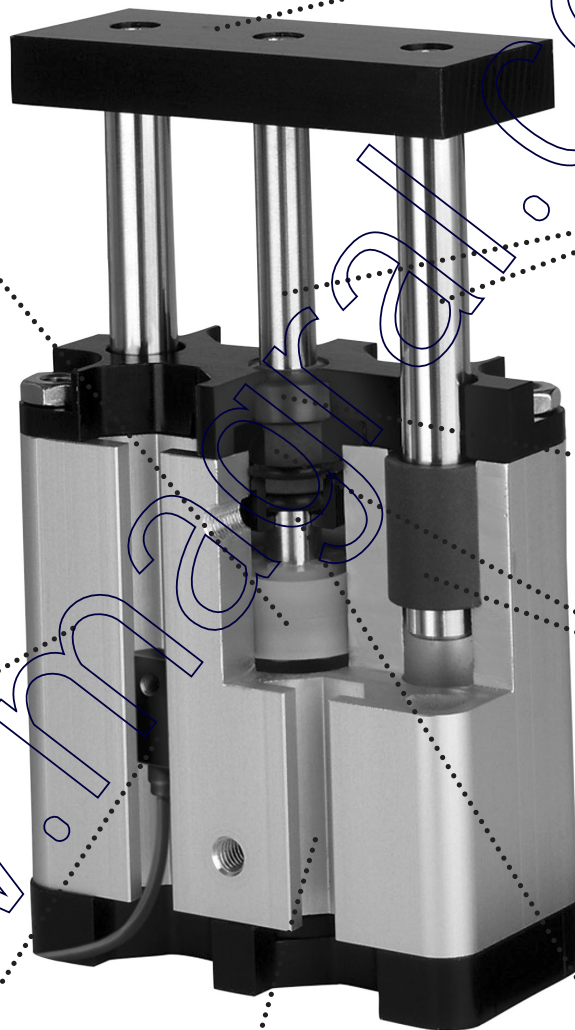

Tooling Plate

- Black anodized aluminum
- Available with tapped or counter bored holes and dowel locators
- Blank or custom plates also available

Piston and Guide Rods

- High strength, precision chrome-plated steel
- Superior wear resistance
- Stainless steel rods available

Rod Wiper (Optional)

- Durable urethane construction provides secondary seal

Piston and Guide Rod Bearings

- Durable and self-lubricating, providing rigid support
- Other bearing materials available

Rod Seal

- Nitrile seal

Extruded Mounting Slots

- Integrated for flexible mounting

Patented ENERSORB™ Piston

- Innovative design integrates seal, wear band, magnet and bumpers into one component
- High energy absorption
- Reduces noise more than 50%
- Extended cycle life from unique blend of urethane material
- Excellent for non-lubrication applications
- Unparalleled repeatable stroke

Body

- High strength, light weight extruded aluminum
- Anodized internal bore for longer cylinder life

Sensors

- Reed, PNP and NPN electronic
- Low profile mounting below body surface
- Integral LED

How to Order: Guided Rod (GR) Cylinders

SERIES	BORE	BEARING TYPE	GUIDE TYPE	STROKE	TOOLING PLATE OPTION	OPTIONS	OPTIONS
GR	12	C	SE	3.00	N23	N30	N50
1	2	3	4	5	6	6	6

1 Model	
GR	Guided Rod Cylinder

2 Bore	
05	1/2"
07	3/4"
12	1 1/4"
25	2 1/2"

3 Bearing Type	
C	Composite Bearing
P	Pacific Bearings
B	Linear Ball Bearing

4 Guide Type Certain stroke lengths may require use of "SL"		
SE	Single End	
SG	SE, 1/8" Tooling Plate Gap	
DE	Double End	
DG	DE, 1/8" Tooling Plate Gap	
SL	For Strokes Exceeding	
	Bore	Stroke
	1/2"	2"
	3/4"	4"
	1 1/4"	6"
2 1/2"	8"	

5 Stroke (example 2" = 2.00) Certain stroke lengths may require use of "SL" in "Guide Type"	
X.XX	Single End
X.XX	Double End

6 Options	
N10	Stop Collar Retract
N11	Stop Collar, Extend**
N22	Bridge Plate
N23	Tapped Tooling Plate (STD)
N24	Counterbored Tooling Plate
N26	Blank Tooling Plate
N30	Magnetic Piston (Order Sensors Separately)
N40	Stainless Steel Piston Rod & Guide Rods*
N50	Body Through Hole Mtg.
N51	Body Threaded Hole Mtg. (Not available on 2 1/2" bore C.F.)
150	Front Flange
151	Rear Flange

*NOTE: Not available with Linear Ball Bearing.

**NOTE: N11 Only Available with Guide Type "DE"

Options & Mounting

Stop Collars		
Bore	A	B
1/2	.44	.69
3/4	.50	.88
1 1/4	.55	1.13
2 1/2	.75	1.75

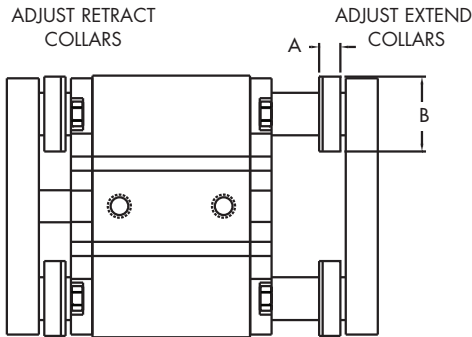

Mounting Nut Dimensions (included*)					
Bore	A	B	C	D	E
1/2	.75	.44	.38	.16	#8-32
3/4	1.13	.63	.56	.25	1/4-20
1 1/4	1.13	.63	.56	.25	1/4-20
2 1/2	1.75	1.25	.88	.25	5/16-18

*NOTE: Reference table below for quantity of nuts.

NOTE: Adjustable collars may interfere when collar is wider than tooling plate gap.

Bridge Plate		
Bore	A	B
1/2	3.75	1.94
3/4	4.18	2.31
1 1/4	4.93	2.66
2 1/2	6.69	3.63

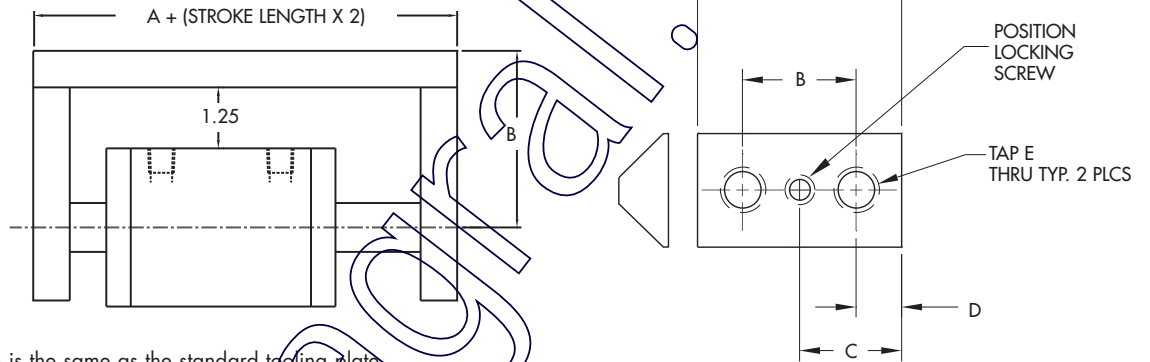

NOTE: Bridge plate width is the same as the standard tooling plate.

Bore	Kit Part Number (1 Each)
1/2" Bore	GRNUTSØ5KIT
3/4" & 1-1/4" Bore	GRNUTSØ7KIT
2-1/2" Bore	GRNUTS25KIT

Quantity of Mounting Nuts				
Stroke	Bore Size			
	1/2"	3/4"	1-1/4"	2-1/2"
1-3	4	4	4	4
4-6	8	6	8	6
7-10	12	10	12	10
10+	12	12	12	12

NOTE: Mounting nuts are included.



Dimensional Data

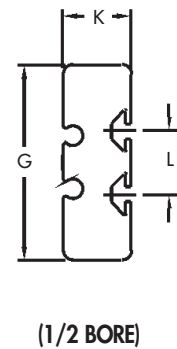
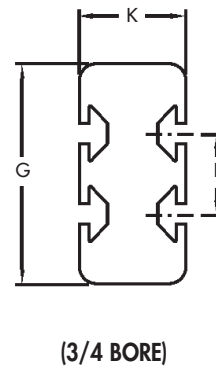
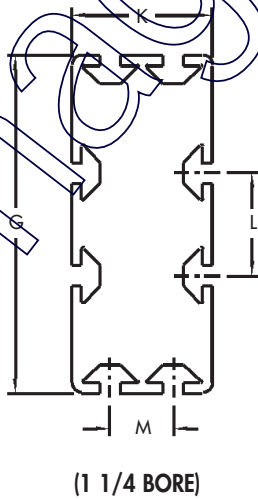
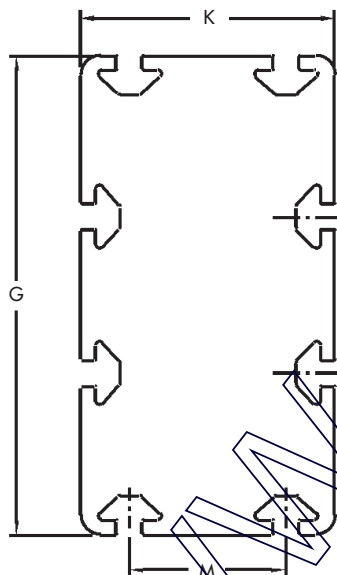
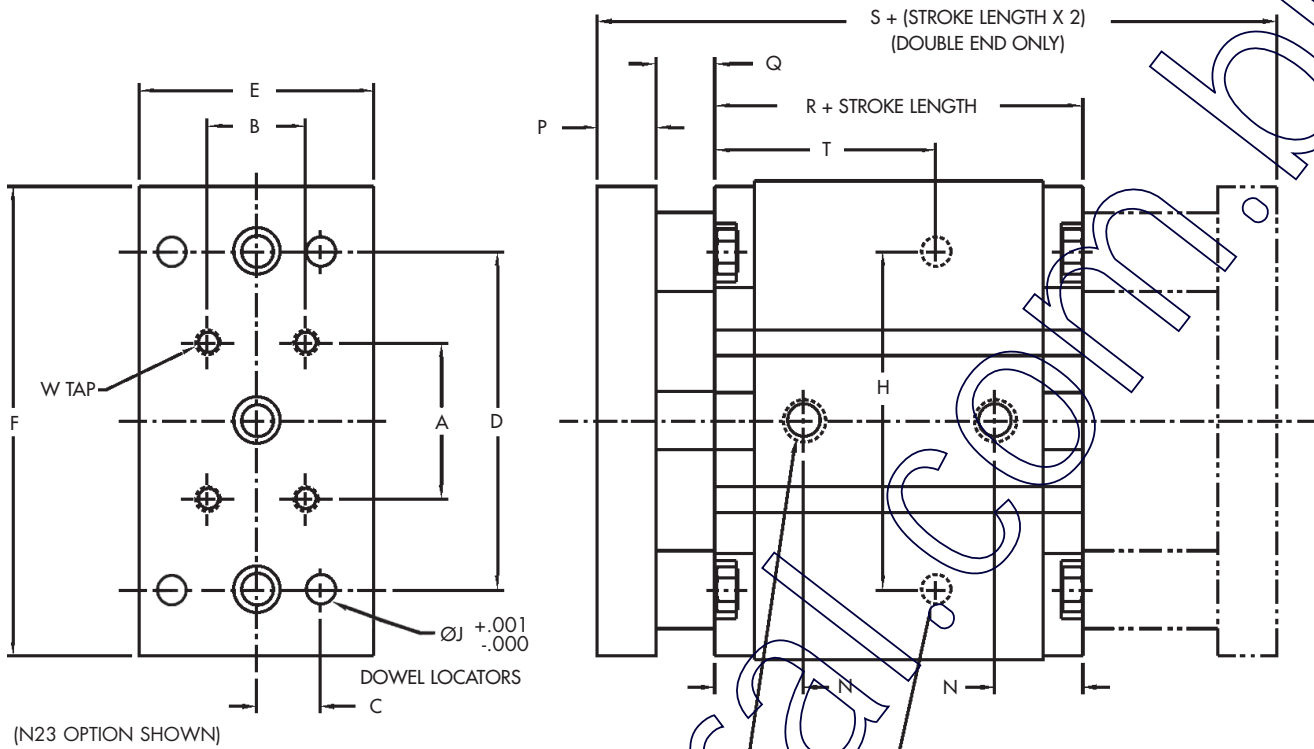

Dimensional Specifications

Bore	A	B	C	D	E	F	G	H	J	K	L	M	N	P	Q	R	S	T	U	V	W
1/2	.81	.44	.25	1.50	.75	2.47	2.50	1.50	.126	.88	.81	N/A	.63	.38	.50	2.00	3.75	.88	.126	#10-32	#8-32
3/4	1.03	.63	.38	1.88	1.13	2.75	2.81	1.88	.188	1.36	1.03	N/A	.71	.38	.50	2.43	3.93	1.31	.188	#10-32	1/4-20
1 1/4	1.31	.63	.50	2.63	1.50	3.69	4.31	2.63	.251	1.80	1.31	.81	.90	.50	.50	2.93	4.93	1.63	.251	1/8 NPT	1/4-20
2 1/2	2.00	1.25	.81	4.32	3.00	6.00	6.13	4.32	.376	3.25	2.00	2.00	1.13	.75	.75	3.69	6.69	2.81	.376	1/4 NPT	5/16-18

Deflection & Force Data

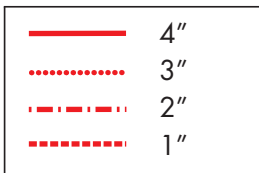
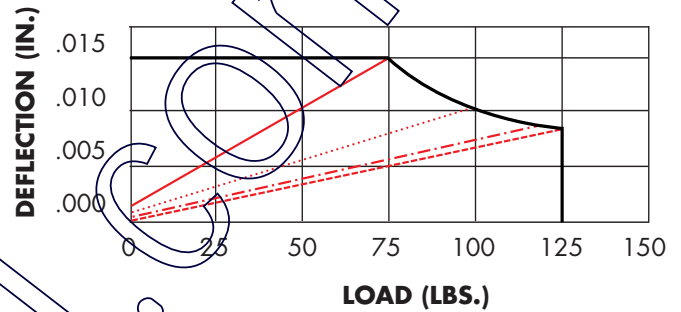
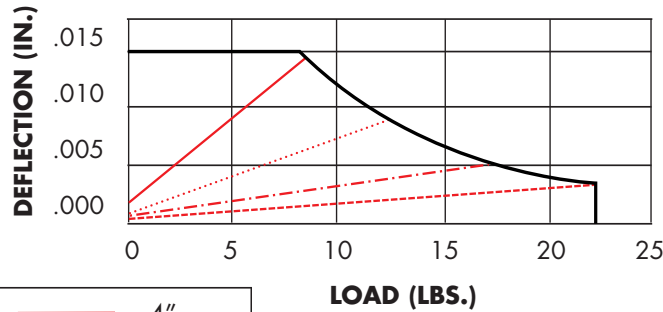
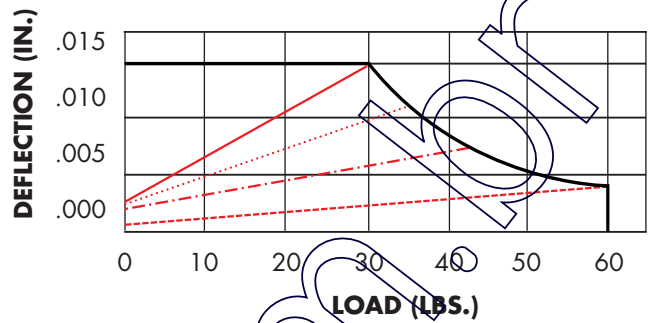
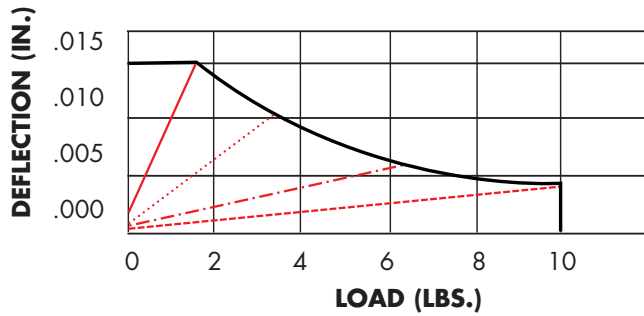

Force Chart				
Bore		Theoretical Force (LBS.) at:		
		50 PSI	100 PSI	150 PSI
1/2"	Extend	9.8	19.6	29.4
	Retract	8.4	16.8	25.3
3/4"	Extend	22.1	44.2	66.3
	Retract	18.3	36.5	54.8
1 1/4"	Extend	61.4	122.7	184.1
	Retract	51.6	103.1	154.7
2 1/2"	Extend	245.4	490.9	736.3
	Retract	223.3	446.7	670.0

How To Use Deflection Charts

When selecting cylinder size, we recommend choosing parameters underneath the upper limit line (red). Selections above the upper limit line may adversely affect cylinder life or operation.

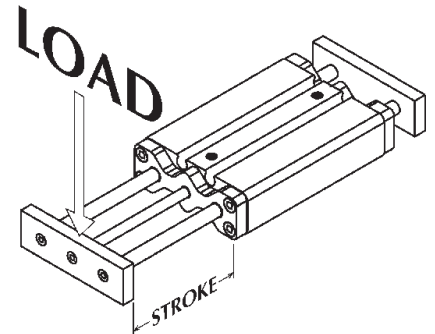

Sensors

HALL EFFECT SENSOR PNP SOURCING

VOLTAGE
6-24 VDC
CURRENT
200 mA MAX

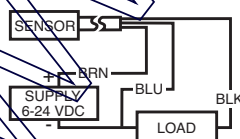

HALL EFFECT SENSOR NPN SINKING

VOLTAGE
6-24 VDC
CURRENT
200 mA MAX

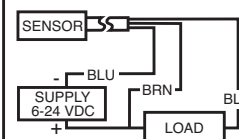

AC/DC REED SENSOR

VOLTAGE
5-120 VAC/VDC
CURRENT
1 mA MIN TO
30 mA MAX

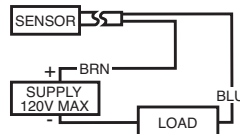

Special Note:

1. Sensors will be permanently damaged if operated without a load.
2. Do not exceed ratings or short circuit load.

Part Numbers

Bore	PNP Sourcing	NPN Sinking	Reed
1/2"	GRP-05	GRN-05	GRR-05
3/4"	GRP-07	GRN-07	GRR-07
1 1/4"	GRP-07	GRN-07	GRR-07
2 1/2"	GRP-25	GRN-25	GRR-25

NOTE: These part numbers represent one sensor and its mounting hardware.