

oemseries.com.br

## **OEM Series Actuators**



*Answer Engineering*

**COMPACT**<sup>®</sup>

**AUTOMATION PRODUCTS LLC**

An **IMC** Company

# OEM Series Actuators: Table of Contents

## OEM Series

<b>OEM 1-1/4" (OC) Series</b> .....	pg. 2
How to Order: OEM 1-1/4" (OC) Series.....	pg. 3
Dimensional Data.....	pg. 4
<b>OEM 2-1/2" (OT) Series</b> .....	pg. 5
How to Order: OEM 2-1/2" (OT) Series.....	pg. 6
Dimensional Data.....	pg. 7
<b>OEM Options</b>	
Flange Mount.....	pg. 8
Combination Flange.....	pg. 9
Side Angle Mounts.....	pg. 10
Extended Tie Rods.....	pg. 11
Adjustable Stroke Control (ASC).....	pg. 12
Urethane Bumpers.....	pg. 13
Cap Switch Systems.....	pg. 14
Trantorque®.....	pgs. 15-16

**OEM (OC) SERIES ACTUATOR PG. 2**



**OEM OPTIONS: ASC PG. 12**

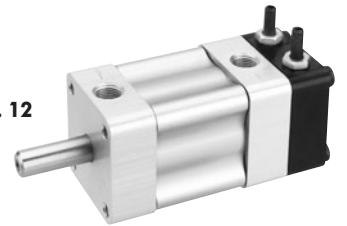

**OEM (OT) ACTUATOR WITH INTEGRAL RODHEAD FLANGE OPTION, PORT ON SHORT SIDE PG. 9**

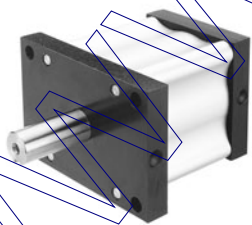

**URETHANE BUMPERS PG. 13**



**OEM (OC) SERIES ACTUATOR PG. 5**



# OEM 1-1/4" (OC) Series

## ROTARY VANE ACTUATORS:

- 15 base models with torque outputs from 9 in. lbs. to 100 in. lbs.
- Rotations 90, 180 & 270 degrees.

### As compared to other rotary devices...

#### Vane actuators have:

- One moving part providing:
  - ZERO backlash.
  - No loss of motion.
  - Smooth rotation.
  - Precise repeatability.
  - Continuous full torque throughout rotation.
- Compact Patented Urethane seals for:
  - Long cycle life and Non-lube service.
  - Actual applications with 25 million cycles and more.
- 100s of standard options and modifications.

**Just imagine... How Compact Automation Answer Engineering can work for you!**

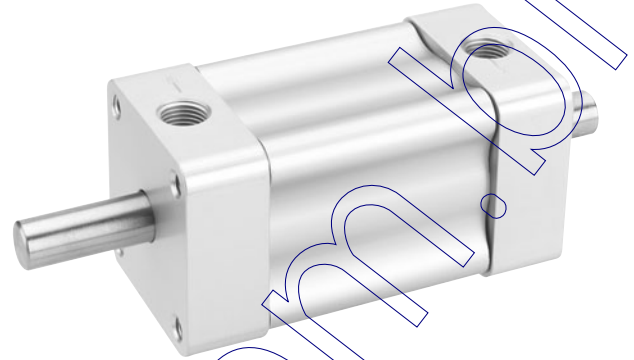

**OEM SERIES ACTUATOR  
MODEL NUMBER: 532-5Q1**

Torque Chart (IN. LBS.)			
180° and 270° Rotations <sup>2</sup>			
Actuator Model	Actuator Torque at		
	100 PSI	80 PSI	60 PSI
511	9	7	5
513	13	10	8
521	25	20	15
523	32	26	19
531	50	40	30
533			
541			
543			
561			
563			

Torque Chart (IN. LBS.)			
90° Rotations <sup>2</sup>			
Actuator Model	Actuator Torque at		
	100 PSI	80 PSI	60 PSI
512	17	14	10
522	32	26	19
532	44	35	26
542	60	48	36
562	100	80	60

## SPECIFICATIONS

### Unit Materials

Stator/Rotor Seals...Urethane  
 Shaft/Tube Seals .....Buna<sup>1</sup>  
 Shaft ..... 303 Stainless Steel  
 Body.....Anodized Alum.  
 Bearings.....Delrin

### Shaft Load Capacities

\*Max. Side Load .....50lbs.  
 \*Max. End Load .....5lbs.

### Miscellaneous

Inlets .....1/8 NPT  
 Min. Pressure .....40 psi  
 Max. Pressure .....100 psi  
 Cylinder Bore .....1-1/4"

### Temperature Range

-20°F to 180°F. Consult factory for higher temperature.

### Filtration

Air.....25-50 microns

### Cycle Rates<sup>3</sup>

Max. non-lubed rate:  
 Double Vane .....40cpm  
 Single Vane .....20cpm

Max. lubed rate:  
 Consult Factory

### Rotary Motion Backlash

All models .....0 degree

### Leak Rates

Air.....4 cfm or less@100psi

- 1 Viton Optional
- 2 All rotations are nominal +4/-0 actual
- 3 Cycle = Start position to end of rotation and returning to the start position.  
Stroke = 1/2 cycle

Capacity per Stroke <sup>3</sup> (IN <sup>3</sup> )			
270° Rotation <sup>2</sup>		90° Rotation <sup>2</sup>	
511	0.50	512	0.42
521	0.99	522	0.84
531	1.49	532	1.26
541	1.99	542	1.68
561	3.49	562	2.96

Weights (OZs)			
270° Rotation <sup>2</sup>		90° Rotation <sup>2</sup>	
511	8	512	8
521	10	522	10
531	12	532	12
541	14	542	14
561	18	562	18

# How to Order: OEM 1-1/4" (OC) Bore Series

**MODEL**      **END CAPS**      **SHAFT**      **UNIT MATERIAL**      **OPTIONS**      **OPTIONS**  
 511 - 1      Y      1      -      XXX      -      XXX  
 1              2              3              4              5              5

**1**

Model			
Model	Series	Torque	Rotation
511	OC	- 09	- 270
512	OC	- 17	- 90
513	OC	- 09	- 180
521	OC	- 13	- 270
522	OC	- 25	- 90
523	OC	- 13	- 180
531	OC	- 25	- 270
532	OC	- 44	- 90
533	OC	- 25	- 180
541	OC	- 32	- 270
542	OC	- 60	- 90
543	OC	- 32	- 180
561	OC	- 50	- 270
562	OC	- 100	- 90
563	OC	- 50	- 180

**2**

End Caps	
To Specify other modifications; Consult Factory	
5	Pneumatic- Clear Anodize

**3**

Shaft	
To Specify other modifications; Consult Factory	
Y	Single End - No Keyway (STD)
M	Double End - No Keyway Each End
W	Single End - Woodruff Key
V	Double End - Woodruff Key Each End
U	Single End - Shaft Flat
T	Double End - Shaft Flat Each End
S	Single End - Keyway
R	Double End - Keyway Each End
Q	Single End - Acces. Stub other End

**4**

Unit Materials	
Shaft - Body - Trim	
1	303 Stainless Steel - Anodized Aluminum - Carbon Steel
3	303 Stainless Steel - Anodized Aluminum - Stainless Steel
4	303 Stainless Steel - Stainless Steel - Stainless Steel
6	316 Stainless Steel - 316 Stainless Steel - Stainless Steel

**5**

Options	
Additional options available on pg. 7	
000	No Options
100	Flange Mount - Rod End
101	Flange Mount - Cap End
300	Extended Tie Rods - Rod End
301	Extended Tie Rods - Cap End
400	Adjustable Stroke Control - Cap End, Pos.5
401	Adjustable Stroke Control - Rod End, Pos.1
801	Side Mounts - Positions 2 & 6
803	Side Mounts - Positions 4 & 8
804	Side Mounts - Positions 2, 4, 6 & 8
900	Thrust Protection - Cap End, Pos.1
901	Thrust Protection - Rod End, Pos.1
B00	Urethane Bumpers
T01	3/8" Trantorque® Shaft Coupler - Carbon Steel
T02	3/8" Trantorque® Shaft Coupler - Stainless Steel

**Switch Options**

Additional switch options available on pg. 14

All Axx Switch Options are Single End Only

A00	Switch Package - No Switches
A02	Switch Pkg. - 2 Reed Switches
A05	Switch Pkg. - 2 Sourcing Switches
A08	Switch Pkg. - 2 Sinking Switches

Double end switch options available on pg. 14



# Dimensional Data: OEM 1-1/4" (OC) Series

## Basic Dimensions

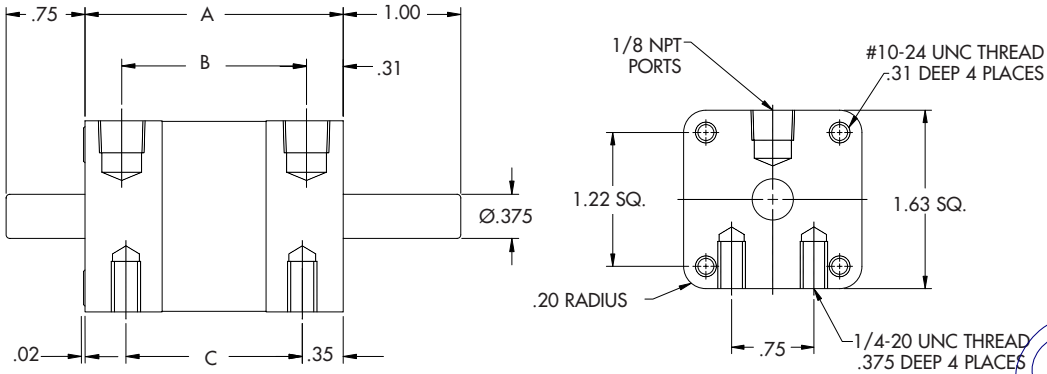

Dimensional Specifications			
Actuator	A	B	C
51X	1.70	1.07	1.00
52X	2.20	1.57	1.50
53X	2.70	2.07	2.00
54X	3.20	2.57	2.50
56X	4.75	4.12	4.05

## Shaft Options

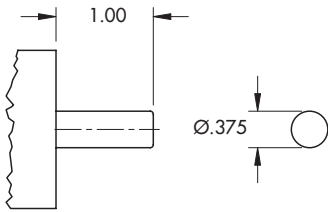

Basic Shaft

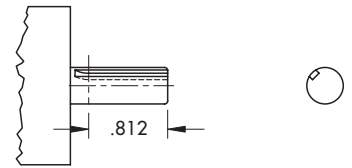

3/32" Square Keyway

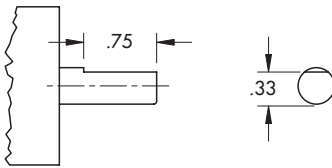

Shaft Flat

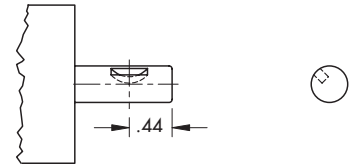

#303 Woodruff Key

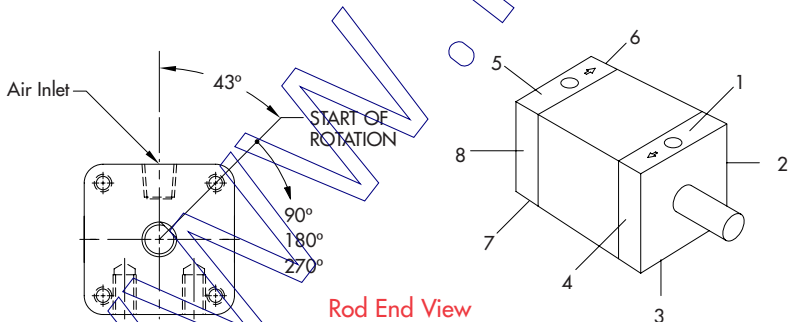

Rod End View

Port & Mounting Position References

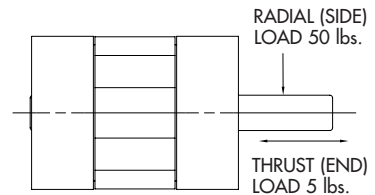

Shaft Load Capacity

Nominal Rotations (+4/-0 actual)

NOTE: The 43° start position is nominal. Tolerances are +/- 2 degrees.

# OEM 2-1/2" (OT) Series

## ROTARY VANE ACTUATORS:

- 16 base models with torque outputs from 87 in. lbs. to 1000 in. lbs.
- Rotations 45°, 90°, 180° & 270° degrees.

### As compared to other rotary devices... vane actuators have:

- One moving part providing:
  - ZERO backlash.
  - No loss of motion.
  - Smooth rotation.
  - Precise repeatability.
  - Continuous full torque throughout the rotation.
- Patented Urethane seals for:
  - Long cycle life and Non-lube service.
  - Actual applications with 25 million cycles and more.
- 100s of standard options and modifications.

**Just imagine... How Compact Automation Answer Engineering can work for you!**

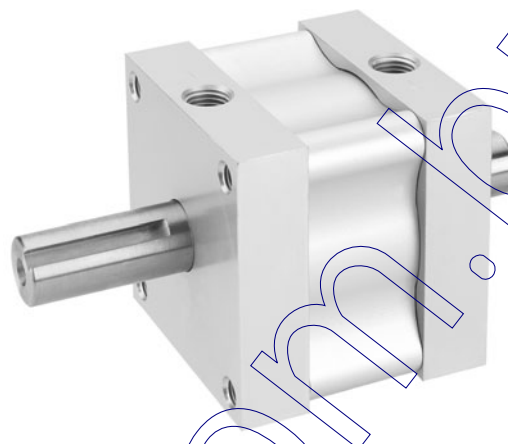

**OEM SERIES ACTUATOR  
MODEL NUMBER: 612-5Q1-000**

Torque Chart (IN. LBS.)			
180° and 270° Rotations <sup>2</sup>			
Actuator Model	Actuator Torque at		
	100 PSI	80 PSI	60 PSI
611	87	70	52
613			
621	175	140	105
623			
631	350	280	210
633			
641	500	400	300
643			

Torque Chart (IN. LBS.)			
45° AND 90° Rotations <sup>2</sup>			
Actuator Model	Actuator Torque at		
	100 PSI	80 PSI	60 PSI
612	175	140	105
614			
622	350	280	210
624			
632	700	560	420
634			
642	1000	800	600
644			

## SPECIFICATIONS

### Unit Materials

Stator/Rotor Seals...Urethane  
 Shaft/Tube Seals.....Buna'  
 Shaft.....1 1/4 Steel  
 Body.....Anodized Alum.  
 Bearings.....Delrin Bushing

### Miscellaneous

Inlets.....1/4 NPT  
 Min. Pressure......35psi  
 Max. Pressure......200 psi<sup>4</sup>  
 Cylinder Bore.....2-1/2"

### Shaft Load Capacities

Max. Side Load.....100 lbs.  
 Max. End Load.....10 lbs.

### Temperature Range

-20°F to 180°F. Consult factory for higher temperature.

### Filtration

Air.....25-50 microns  
 Hydraulic.....10-25 microns

### Cycle Rates<sup>3</sup>

Max. non-lubed rate:  
 Double Vane.....40cpm  
 Single Vane.....20cpm

Max. lubed rate:  
 Consult Factory

### Rotary Motion Backlash

All models.....0 degree

### Leak Rates

Air.....4 cfh or less@100psi

- 1 Viton Optional
- 2 All rotations are nominal +4/-0 actual
- 3 Cycle = Start position to end of rotation and returning to the start position.  
Stroke = 1/2 cycle

Capacity per Stroke <sup>3</sup> (IN <sup>3</sup> )			
270° Rotation <sup>2</sup>		90° Rotation <sup>2</sup>	
611	4.52	612	2.75
621	8.50	622	5.50
631	17.00	632	11.00
641	27.50	642	16.70

Weights (LBS.)			
270° Rotation <sup>2</sup>		90° Rotation <sup>2</sup>	
611	2.5	612	2.5
621	3.3	622	3.3
631	6.0	632	6.0
641	9.3	642	9.3

# How to Order: OEM 2-1/2" (OT) Bore Series

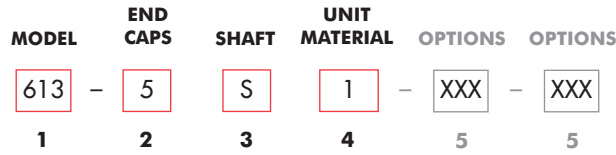

Model			
Model	Series	Torque	Rotation
611	OT	87	270
612	OT	175	90
613	OT	87	180
614	OT	175	45
621	OT	175	270
622	OT	350	90
623	OT	175	180
624	OT	350	45
631	OT	350	270
632	OT	700	90
633	OT	350	180
634	OT	700	45
641*	OT	500	270
642*	OT	1000	90
643*	OT	500	180
644*	OT	1000	45

\* These models require '2' or '5' for the selection in block #4 "Unit Materials".

End Caps	
To Specify other modifications; Consult Factory	
5	Pneumatic- Clear Anodize

Shaft	
To Specify other modifications; Consult Factory	
Y	Single End - No Keyway
M	Double End - No Keyway Each End
W	Single End - Woodruff Key
V	Double End - Woodruff Key Each End
U	Single End - Shaft Flat
T	Double End - Shaft Flat Each End
S	Single End - Keyway
R	Double End - Keyway Each End
Q	Single End - Acces. Stub other End

Unit Materials	
Shaft - Body - Trim	
1	1144 Carbon Steel - Anodized Aluminum - Carbon Steel
2	Hardened Carbon Steel - Anodized Aluminum - Carbon Steel
3	303 Stainless Steel - Anodized Aluminum - Stainless Steel
4	303 Stainless Steel - 303 Stainless Steel - Stainless Steel
5	Hardened 440 SS - Anodized Aluminum - Stainless Steel
6	316 Stainless Steel - 316 Stainless Steel - Stainless Steel

Options	
Additional options available on pg. 7	
000	No Options
100	Flange Mount - Rod End
101	Flange Mount - Cap End
200	Side Angle Mounting Brackets - Mounting Surface 3 & 7
300	Extended Tie Rods - Rod End
301	Extended Tie Rods - Cap End
320	Extended Tie Rods - Both Ends
400	Adjustable Stroke Control - Cap End, Pos.5
401	Adjustable Stroke Control - Rod End, Pos.1
500	Electrical Position Indicator - Cap End, Pos. 5
704	Teflon Impregnated Hard Anodized
801	Side Mounts - Positions 2 & 6
803	Side Mounts - Positions 4 & 8
804	Side Mounts - Positions 2, 4, 6 & 8
900	Thrust Protection - Cap End, Pos.1
901	Thrust Protection - Rod End, Pos.1
B00	Urethane Bumpers
T01	3/4" Trantorque® Shaft Coupler - Carbon Steel
T02	3/4" Trantorque® Shaft Coupler - Stainless Steel  Stainless Shaft Coupler has 1/3 the Transmissible Torque as T01 (see pg. 15)
Switch Systems	
Additional switch options available on pg. 14	
All Axx Switch Options are Single End Only	
A00	Switch System -No Switches
A02	Switch System -2 Reed Switches
A05	Switch System -2 Sourcing Switches
A08	Switch System -2 Sinking Switches
Double end switch options available on pg. 14	

# Dimensional Data: OEM 2-1/2" (OT)

## Basic Dimensions

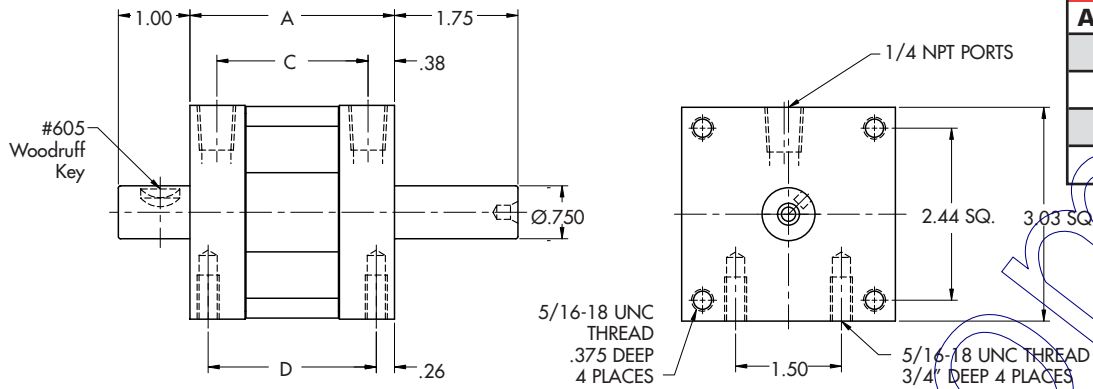

Dimensional Specifications			
Actuator	A	C	D
61X	2.90	2.15	2.38
62X	4.40	3.64	3.88
63X	7.42	6.67	6.91
64X	10.38	9.63	9.86

## Shaft Options

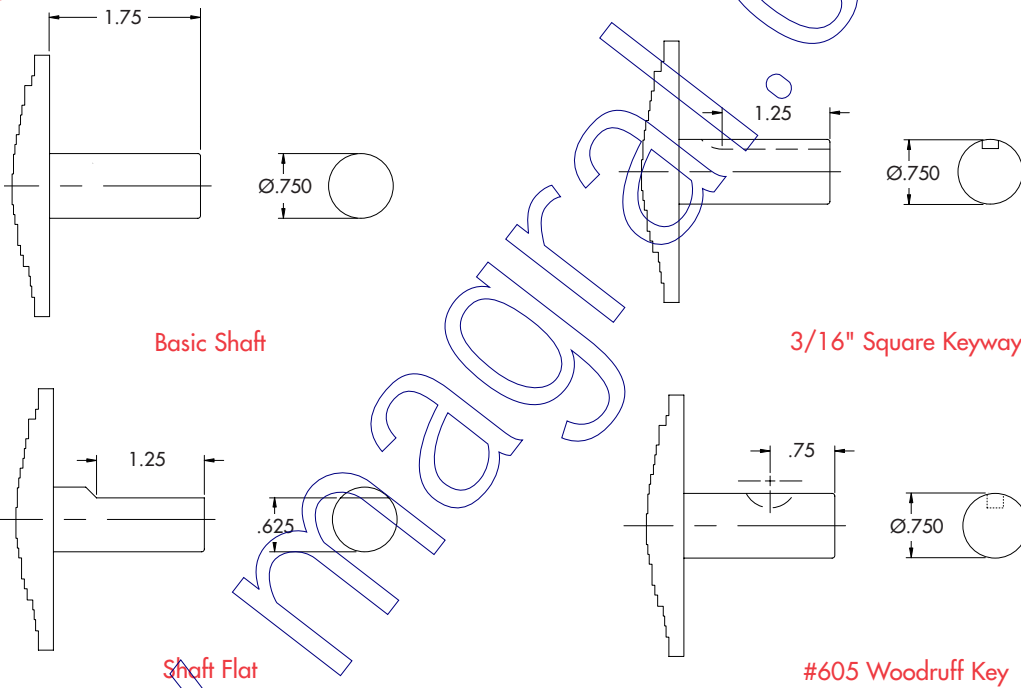

NOTE: Center drill omitted from shaft details for clarity.

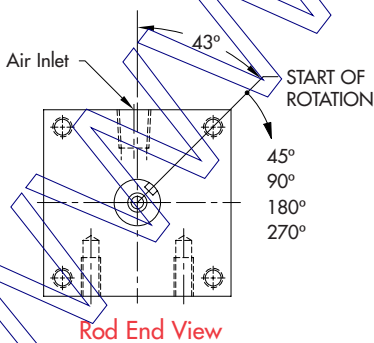

Nominal Rotations (+4/-0 actual)

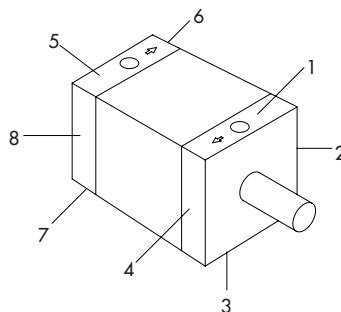

Port & Mounting Position References

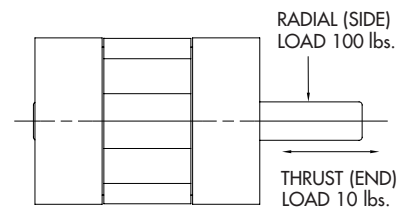

Shaft Load Capacity

NOTE: The 43° start position is nominal. Tolerances are +/- 2 degrees.



# OEM Options- Flange Mount

## OEM 1-1/4 Bore (OC) Series

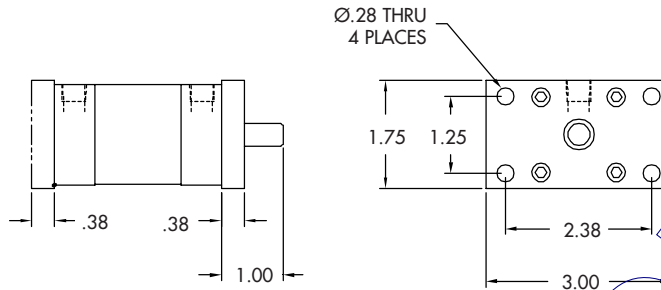

NOTE: Side Mounts surface 3 & 7 are standard, but are not shown for clarity. Standard Bottom Mount dimensions shown on page 3.

## OEM 2-1/2 Bore (OT) Series

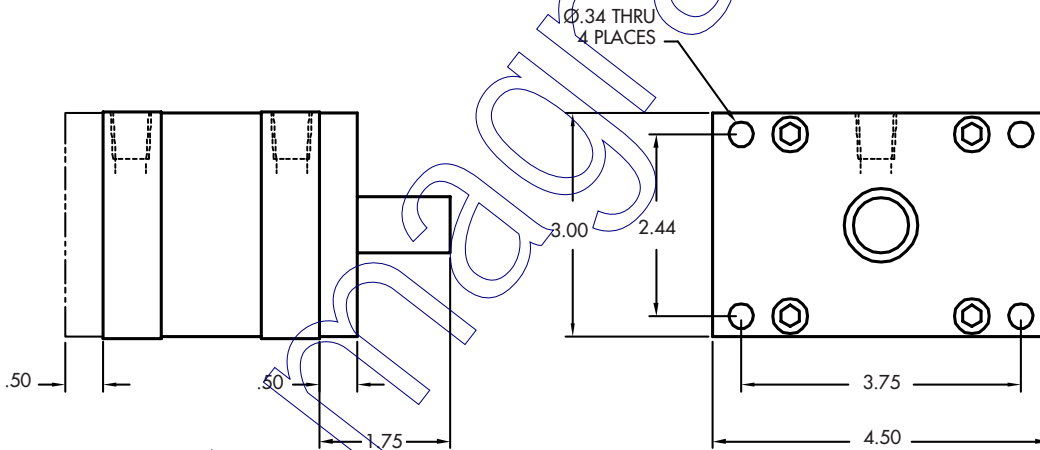

NOTE: Side Mounts surface 3 & 7 are standard, but are not shown for clarity. Standard Bottom Mount dimensions shown on page 6.

NOTE: The Flange Mount option and Adjustable Stroke Control option may not be ordered on the same end of a unit.

Option#	Description
100	Front Flange (Rod End)
101	Rear Flange (Cap End)
102	Front and Rear Flange
Front Flange and Front ASC Combined (See page 8)	

# OEM Options- Combination Flange

The flange option can be combined with either head, or the Adjustable Stroke Control housing of the actuator to minimize the overall length of the actuator.

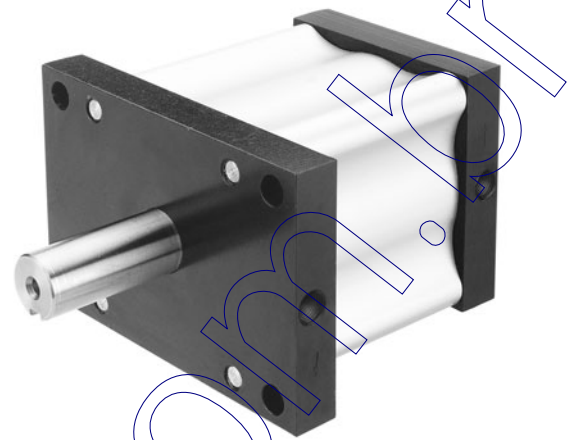

**OEM (OT) ACTUATOR WITH INTEGRAL RODHEAD FLANGE OPTION, PORT ON SHORT SIDE**

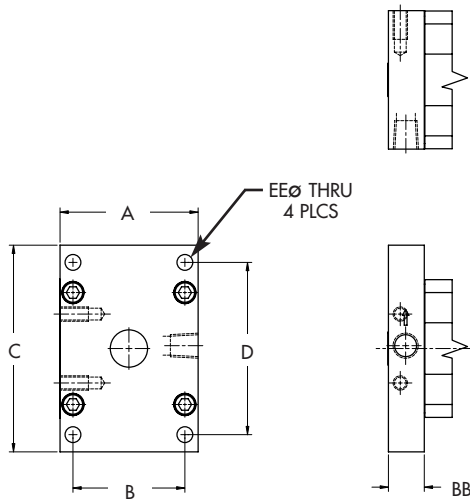

Combination Flange/Rod Head: Port shown on long side

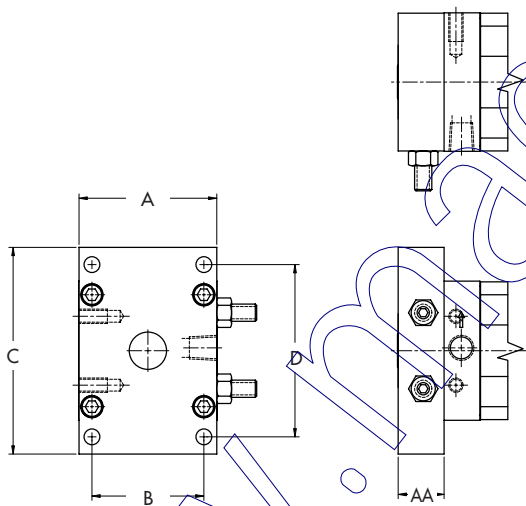

Combination Flange/Adjustable Stroke Control (ASC) Housing:  
The ASC housing and the flange are machined from a single piece of aluminum.

Combo Flanges	OEM 1-1/4 (OC) Series	OEM 2-1/2 (OT) Series
<b>A</b>	1.75	3.00
<b>B</b>	1.25	2.44
<b>C</b>	3.00	4.50
<b>D</b>	2.38	3.75
<b>EEØ</b>	0.28	0.34
<b>ASC Flange (AA)</b>	0.656	1.000
<b>Flange Head (BB)</b>	0.656	0.781

Option #	Description
<b>105</b>	Flange Mount integral with the Adjustable Stroke Control Housing Front Mount.
<b>108</b>	Flange Mount integral with the Adjustable Stroke Control Housing Rear Mount.
<b>110</b>	Flange Mount integral with the Rod Head. Flange positioned with the port on the Long side.
<b>111</b>	Flange Mount integral with the Cap Head. Flange positioned with the port on the Long side.
<b>120</b>	Flange Mount integral with the Rod Head. Flange positioned with the port on the Short side.
<b>121</b>	Flange Mount integral with the Cap Head. Flange positioned with the port on the Short side.

# OEM Options- Side Angle Mounts

Option #	Description
<b>200</b>	Side Angle Brackets, Mounting Surface 3 & 7
<b>201</b>	Side Angle Brackets, Mounting Surface 2 & 6
<b>202</b>	Side Angle Brackets, Mounting Surface 4 & 8
<b>203</b>	Side Angle Brackets, Mounting Surface 1 & 5

NOTE: Specify the surface to be used for mounting. Example: Option 200 would call out surface 3 & 7 as the mounting surface, Option #201 would call out surface 2 & 6 as the mounting surface.

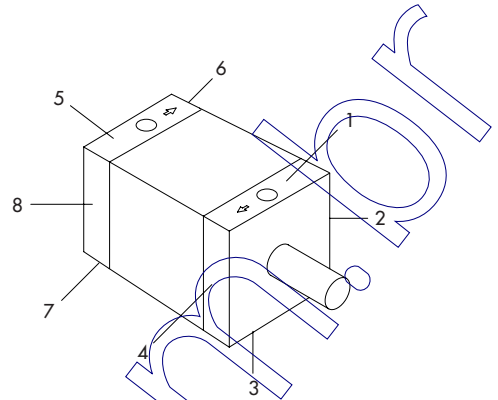

Mounting Surface Reference Drawing

## OEM 2-1/2 Bore (OT) Series

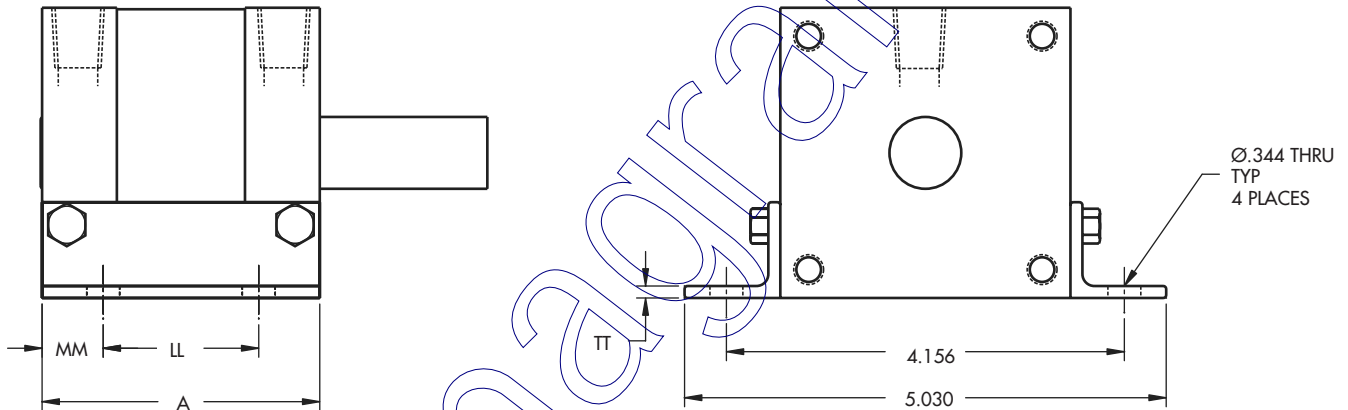

Option 200  
Shown in Drawing

NOTE: Side Mounts surface 3 & 7 are standard, but are not shown for clarity. Standard Bottom Mount dimensions shown on page 6.

OEM OT Model	A	LL	MM	TT
<b>61X</b>	2.90	1.625	.638	.125
<b>62X</b>	4.39	3.000	.694	.125
<b>63X</b>	7.42	6.000	.712	.125
<b>64X</b>	10.38	9.125	.626	.188

# OEM Options- Extended Tie Rods

Option #	Description
300	Extended Tie Rods, Front
301	Extended Tie Rods, Rear
302 <sup>3</sup>	Extended Tie Rods, Front and Rear

**NOTE:**

1. Tie rod material (Carbon Steel or Stainless Steel) is determined by the Unit Material selected for the base actuator.
  2. The Extended Tie Rod option eliminates the standard front mounts.
  3. Option 302 is not available on the OEM 1-1/4" (OC) Series.
- Consult Factory for other variations of this option.

## OEM 1-1/4 Bore (OC) Series

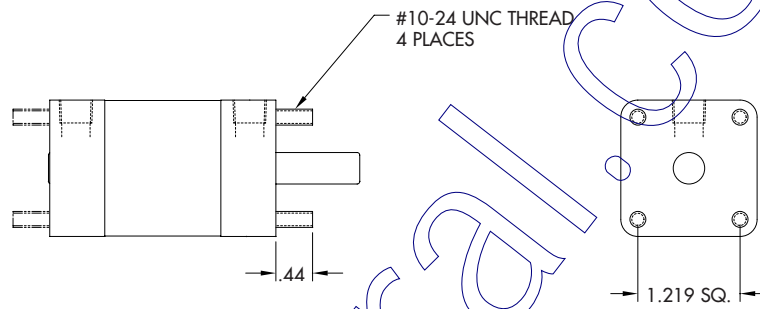

NOTE: Side Mounts surface 3 & 7 are standard, but are not shown for clarity. Standard Bottom Mount dimensions shown on page 4.

## OEM 2-1/2 Bore (OT) Series

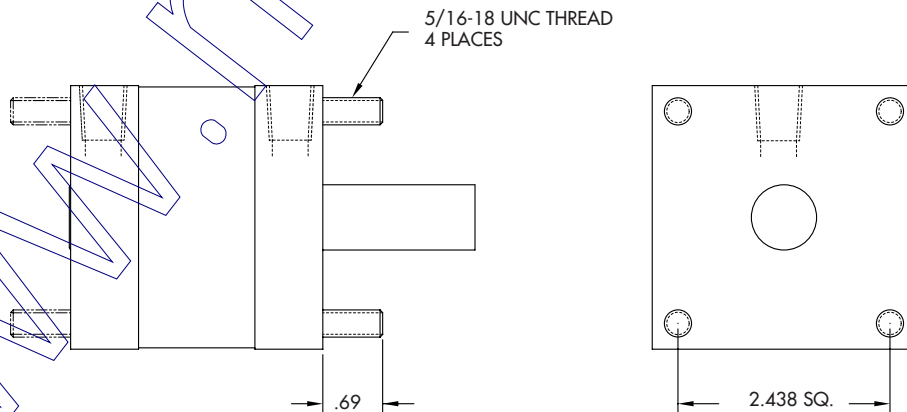

NOTE: Side Mounts surface 3 & 7 are standard, but are not shown for clarity. Standard Bottom Mount dimensions shown on page 7.

# OEM Options- Adjustable Stroke Control (ASC)

The Adjustable Stroke Control (ASC) option allows an actuator to be adjusted to the exact rotational stroke desired. The "ASC" option consists of a shaft mounted steel cam, enclosed in a housing with control screws (see method of operation below). Turning the control screws either extends or limits the amount of rotation. The ends of the control screws impact the cam providing a positive and repeatable end of rotation stop. The ASC option is often specified for applications where the stroke required is not within the rotational tolerance. The standard rotational stroke tolerance of an actuator is  $+4^{\circ} / -0^{\circ}$  (i.e.: A 90-degree actuator without ASC will have a rotation of 90-94° With the addition of the ASC option a precise 90° rotation is attainable.).

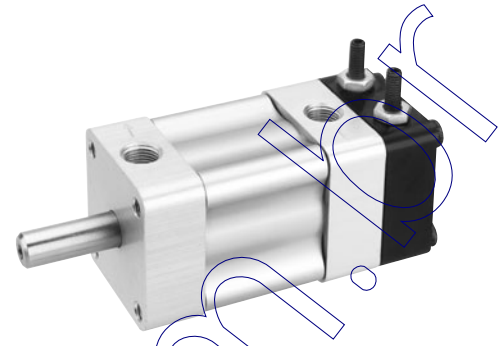

Option #	Description
400	ASC Cap End, Position 5
401	ASC Rod End, Position 1
402	ASC Cap End, Position 6
403	ASC Rod End, Position 2
404	ASC Cap End, Position 7
405	ASC Rod End, Position 3
406	ASC Cap End, Position 8
407	ASC Rod End, Position 4

NOTE: Contact Factory for other adjusting ranges.

Actuator Rotation	Adjusting Range
*45°	0-45 degrees
90°	0-90 degrees
180°	90-180 degrees
270°	90-270 degrees

\* OT Series Only.

NOTE: Rotations greater than 180° are not fully adjustable with a standard 2 screw adjustable stroke control. Consult factory for greater adjustment range.

Adjustable Stroke Control (ASC) Dimension			
MODEL/Series	(A =max) in.	(B) in.	(C) in. Sq.
OEM 1-1/4 (OC)	1.500	0.656	1.63
OEM 2-1/2 (OT)	3.250	1.000	3.03

## POSITION REFERENCE DRAWING

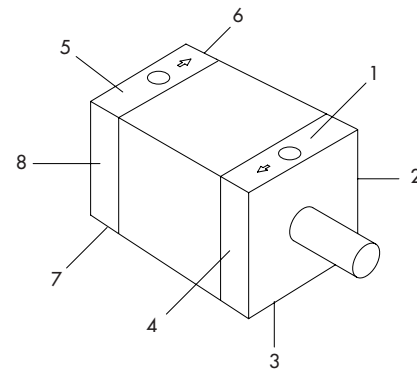

NOTE: Specify the position to be tapped for adjustment screws. Example: Option 407 would call out position 4 as the adjustment screw location, as depicted in the drawing above.

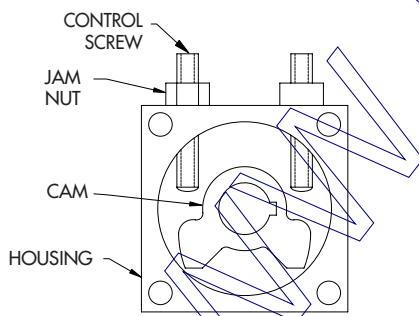

## METHOD OF OPERATION

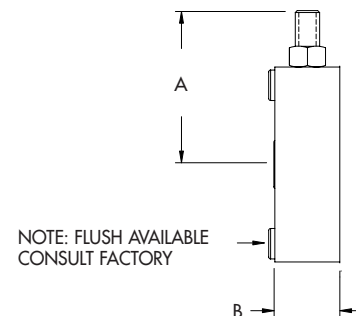
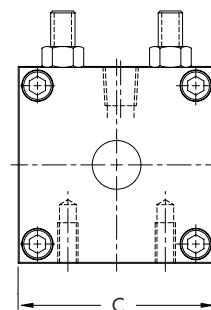

## DIMENSIONAL DATA



# OEM Options- Urethane Bumpers

Polyurethane BUMPERS absorb kinetic energy and reduces noise at the end of stroke. Actual rotation and repeatability achieved when bumpers are installed will be dependent on Load... Air Pressure... and Speed of Rotation.

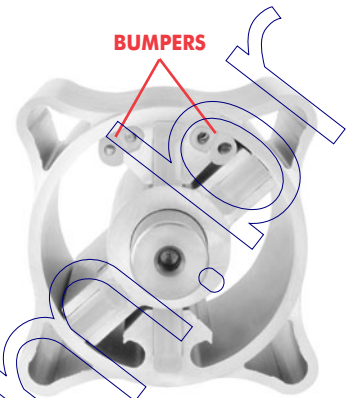

Series	Option #
OEM 1-1/4 (OC)	B00
OEM 1-1/2 (OT)	B00

NOTE: Only 1 end of rotation can be bumpered when the 45-degree rotor is ordered.

# OEM Options- Side Mounts

Option #	Description
<b>SIDE MOUNTS, SIDES 3 &amp; 7 STANDARD ON ALL MODELS (Except Opt. 810)</b>	
800	Side Mounts, Sides 1 & 5
801	Side Mounts, Sides 2 & 6
803	Side Mounts, Sides 4 & 8
804	Side Mounts, Sides 2, 4, 6 & 8
806	Side Mounts, Sides 6 & 8
807	Side Mounts, Sides 2 & 4
810	No Side Mounts (removes Sides 3 & 7)

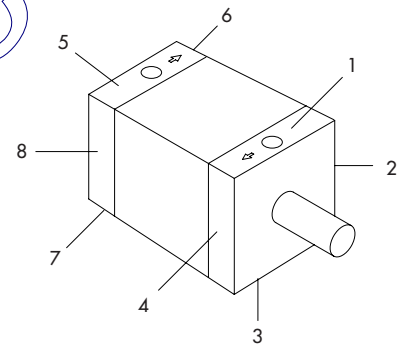

Position Reference Drawing

NOTE: Specify the side to be used for mounting. Example: Option 804 would call out sides 2, 4, 6 & 8 as the mounting surfaces, as depicted in the drawings below. Mount sides 3 & 7 are standard on all models (OT, OC) but are not shown for clarity.

OEM 1-1/4	
Models	D
51X	1.00
52X	1.50
53X	2.00
54X	2.50
56X	4.05

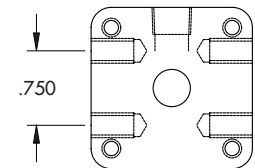
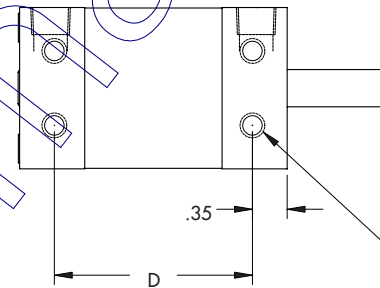

1/4-20 UNC THREAD  
.44 DEEP  
4 PLACES PER SIDE

NOTE: Mounts surface 3 & 7 are standard, but are not shown for clarity. Standard Bottom Mount dimensions shown on page 2.

OEM 2-1/2	
Models	D
61X	2.38
62X	3.87
63X	6.91
64X	9.86

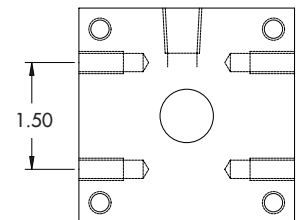
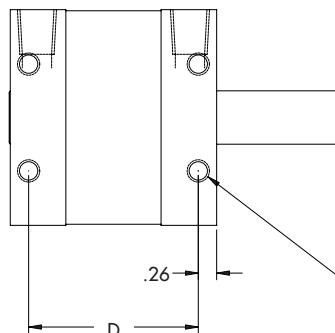

5/16-18 UNC THREAD  
.75 DEEP  
4 PLACES PER SIDE

NOTE: Mounts surface 3 & 7 are standard, but are not shown for clarity. Standard Bottom Mount dimensions shown on page 7.

NOTE: Center drill omitted from shaft details for clarity.

# OEM Options- Cap Switch Systems

OEM Series Rotary Vane Actuators are available with electronic position sensing switches. The switches have LED lamps that light when in sensing position. If adjusted for end of stroke indication, the LED will remain lit as long as the stroke position is maintained. A small shaft mounted magnet in the switch housing operates the switches (See drawings).



SWITCH SYSTEM WITH 8MM QUICK DISCONNECT

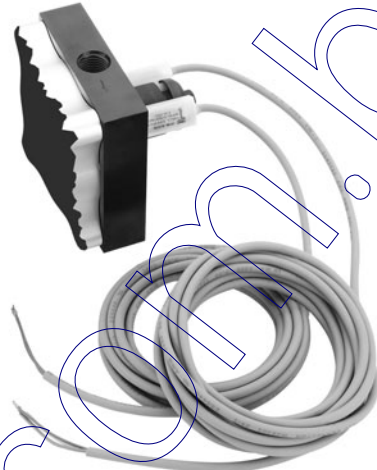

SWITCH SYSTEM WITH 9 FT. LEADS

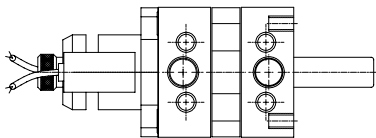

OEM 1-1/4 BORE (OC) SERIES SWITCHES

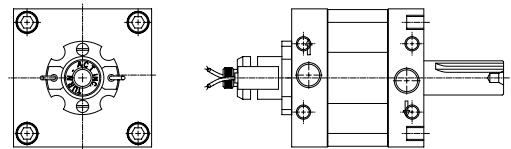
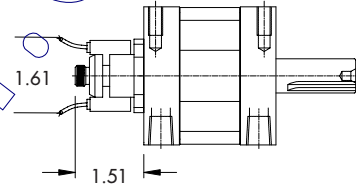

OEM 2-1/2 BORE (OT) SERIES SWITCHES

SWITCH PACKAGE (CAP END)							
Includes a Cap End Mounted Switch Ready Housing							
Option #	Switch Type	Function	Lead Type	Switching Voltage	Switching Current	Switching Power	Max. Voltage Drop
<b>A00</b>	Switch Ready No Switches						
<b>A05</b>	PNP/Sourcing	Normally Open Output	22 gauge	6-24 VDC	0.5 Amp Max	N/A	0.5 Volts
<b>A08</b>	NPN/Sinking	Normally Open Output	22 gauge	6-24 VDC	0.5 Amp Max	N/A	0.5 Volts
<b>A02</b>	AC/DC Reed	SPST Normally Open	22 gauge	5-120 VDC/VAC 50/60 Hz	0.5 Amp Max 0.005 Amp min.	10 watts Max	3.5 Volts
<b>A25</b>	PNP/Sourcing	Normally Open Output	8mm Type - B QD	6-24VDC	0.5 Amp Max	N/A	0.5 Volts
<b>A28</b>	NPN/Sinking	Normally Open Output	8mm Type - B QD	6-24VDC	0.5 Amp Max	N/A	0.5 Volts
<b>A22</b>	AC/DC Reed	SPST Normally Open	8mm Type - B QD	5-120 VDC/VAC 50/60 Hz	0.5 Amp Max 0.005 Amp min.	10 watts Max	3.5 Volts

**Caution:** Switches will be permanently damaged if operated without a load. Consult factory if lead length will exceed 20 ft.

# OEM Options- Trantorque®

## Trantorque

Trantorque keyless shaft couplings eliminates:

- The need for keys, keyways and setscrews.
- Simplifies synchronization.
- Allows for infinite radial adjustments.
- Mounts hubless devices.

The Trantorque coupling uses 2 opposing tapers that expand into the OD and contract on the ID to attach and hold shaft loads.

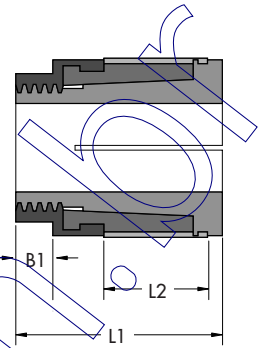
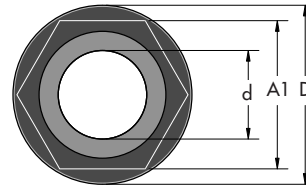

NON-TRAVERSING

Style	Trantorque Series		Part #	Actuator Shaft diameter (d)	Component Bore (D)	Max. Transmissible		Dimensions					
						Tq.	Thrust	L1	L2	A1	A2	B1	B2
Non-Traversing	Imperial Mini	OEM Series 1-1/4" Bore	6980109	3/8"	3/4"	175 in.lbs.	648 lbs.	1-3/16"	7/16"	5/8"	-	1/8"	-
	Imperial Series	OEM Series 2-1/2" Bore	6980160	3/4"	1-1/2"	1750 in.lbs.	3080 lbs.	1-21/32"	11/16"	1-1/4"	1-1/2"	5/16"	5/16"

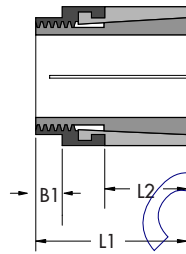
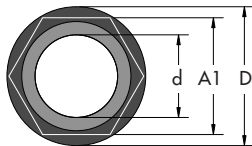

MINI SERIES

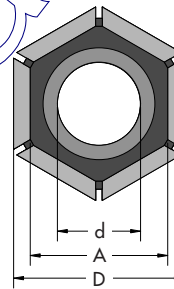

GT SERIES

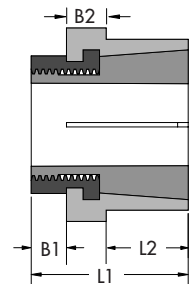

Style	Trantorque Series		Part #	Actuator Shaft diameter (d)	Component Bore (D)	Max. Transmissible		Dimensions					
						Tq.	Thrust	L1	L2	A1	A2	B1	B2
Standard Series	Imperial Mini	OEM Series 1-1/4" Bore	6980109	3/8"	3/4"	250 in.lbs.	925 lbs.	7/8"	7/16"	5/8"	-	1/8"	-
	Imperial Series	OEM Series 2-1/2" Bore	6980160	3/4"	1-1/2"	2500 in.lbs.	4400 lbs.	1-1/2"	3/4"	1-1/4"	1-1/2"	5/16"	5/16"

Style	Trantorque Series		Part #	Actuator Shaft diameter (d)	Component Bore (D)	Max. Transmissible		Dimensions					
						Tq.	Thrust	L1	L2	A1	A2	B1	B2
Stainless Series	Imperial Mini	OEM Series 1-1/4" Bore	6980109	3/8"	3/4"	75 in.lbs.	280 lbs.	7/8"	7/16"	5/8"	-	1/8"	-
	Imperial Series	OEM Series 2-1/2" Bore	6980160	3/4"	1-1/2"	750 in.lbs.	1320 lbs.	1-1/2"	3/4"	1-1/4"	1-1/2"	5/16"	5/16"

# OEM- Trantorque® (cont.)

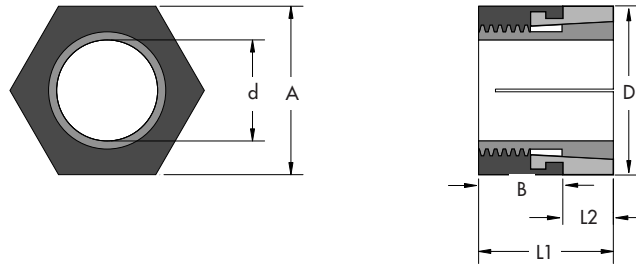

SHORT SERIES

Style	Trantorque Series		Part #	Actuator Shaft diameter (d)	Component Bore (D)	Max. Transmissible		Dimensions			
	Imperial Mini	OEM Series 1-1/4" Bore				Tq.	Thrust	L1	L2	A	B
Short Series	Imperial Mini	OEM Series 1-1/4" Bore	6980109	3/8"	3/4"	250 in.lbs.	925 lbs.	5/8"	1/4"	3/4"	3/8"
	Imperial Series	OEM Series 2-1/2" Bore	6980160	3/4"	1-1/2"	2500 in.lbs.	4400 lbs.	1-1/4"	1/2"	1-1/2"	3-4"

# OEM Options- Hub Adapter

This option provides an alternative to the conventional output shaft. The Hub Adapter option allows for easy mounting of grippers, tooling, actuators, cylinders and other end effectors that require a flat mounting surface.

The Hub is manufactured of aluminum with 4 counter bored through holes on one side and threaded holes on other. Trantorque (see Trantorque section) is used in mounting of the Hub Adapter to the actuator shaft. This attachment method provides infinite hub/hole orientation.

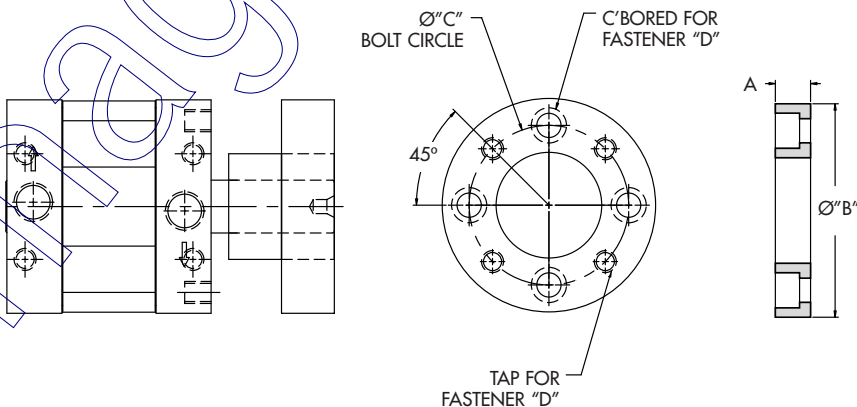

TRANTORQUE WITH ADAPTOR HUB

Option #	Description
M10	W/Mild Steel Trantorque
M20	W/Stainless Steel Trantorque

Hub Adapter Dimensions	OEM 1-1/4 (OC) Series	OEM 2-1/2 (OT) Series
A	0.438"	0.750"
B	1.563"	2.500"
C	1.156"	2.000"
D	#10-24	1/4-20

NOTE: Contact Factory for other hub diameters, bolt hole patterns, etc.

## Special Conditions and Limited Warranty

Determination of the suitability of any information or product for the application contemplated by any user or the manner of that use is the sole responsibility of the user.

Compact Automation Products, LLC reserves the right to improve or change designs without notice.

All orders are subject to acceptance by the factory sales department.

Compact Automation Products, LLC agrees to repair or replace to the original purchaser any standard parts or products for a period of 12 months from date of shipment which Compact Automation Products, LLC determines upon inspection to be defective in workmanship or material. Wear components including but not limited to seals and bearings are excluded from this warranty.

Under no circumstance may merchandise be returned without written authorization from the factory.

This warranty is void in the event the product has been tampered with, altered, or serviced by unauthorized personnel.

Compact Automation Products, LLC's total responsibility for any claims, damages, losses or liabilities related to the product covered thereunder shall not exceed the purchase price of such product. In no event shall Compact Automation Products, LLC be liable for any special, indirect, incidental or consequential damages of any character, including but not limited to loss of use of productive facilities or equipment, lost profit, property damage, transportation, installation or removal or lost production whether suffered by purchaser or third party. Compact Automation Products, LLC Inc. disclaims all liability for any and all cost, claims demands, charges, expenses, and other damages, either direct or indirect, incident to all property damage arising out of any cause of action based on strict liability. This warranty gives you specific legal rights and you may have other rights, which vary from state to state.

*Answer Engineering*  
**COMPACT**<sup>®</sup>  
AUTOMATION PRODUCTS LLC  
An **IMC** Company

Compact Automation Products LLC  
105 Commerce Way  
Westminster, SC 29687  
USA  
Tel: 864.647.9521  
Fax: 864.647.9574  
[www.compactautomation.com](http://www.compactautomation.com)

Just imagine...  
How Compact Automation Product's  
Answer Engineering can work for you!