

Shock Absorbers and Rate Controls



ENIDINE
Shock Absorbers and Rate Controls

ENIDINE



HI Series

ITT Enidine's **Heavy Industry (HI) Series** buffers safely protect heavy machinery and equipment during the transfer of materials and movement of products. The large-bore, high-capacity buffers are individually designed to decelerate moving loads under various conditions and in compliance with industry mandated safety standards. Control of bridge cranes, trolley platforms, large container transfer and transportation safety stops are typical installation examples. Industry-proven design technologies, coupled with the experience of a globally installed product base, ensure deliverable performance that exceeds customer expectations.

Prior to HI Series buffer manufacture, computer-simulated response curves are generated to model actual conditions, verify product performance, confirm damping characteristics and generate unique custom-orificed designs that accommodate multi-condition or specific damping requirements.

Characteristics of the HI Series include a nitrogen-charged return system that allows for soft deceleration and positive return in a maintenance-free package. The oversize bore area results in optimal energy absorption capabilities and increased internal safety factors. State-of-the-art testing facilities ensure integrity of design and product performance.

Features and Benefits

- Compact design smoothly and safely decelerates large energy capacity loads up to 4 million in-lbs. per cycle with standard stroke lengths.
- Engineered to meet OSHA, AISE, CMMA and other safety specifications such as DIN and FEM.
- Nitrogen-charged return system allows for soft deceleration and positive return in a maintenance-free package.
- Wide variety of optional configurations including protective bellows and safety cables.
- Available in custom-orificed non-adjustable models.
- Special epoxy painting and rod materials are available for use in highly corrosive environments.
- Surface treatment (Sea water resistant)
Housing: gray color, three-part epoxy
Piston Rod: hard-chrome plated steel
- Incorporating optional fluids and seal packages available to expand standard operating temperature range from (0°F to 175°F) to (-30°F to 250°F) (-10°C to 60°C) to (-35°C to 100°C)

ITT Enidine Heavy Industry (HI) Series Buffers

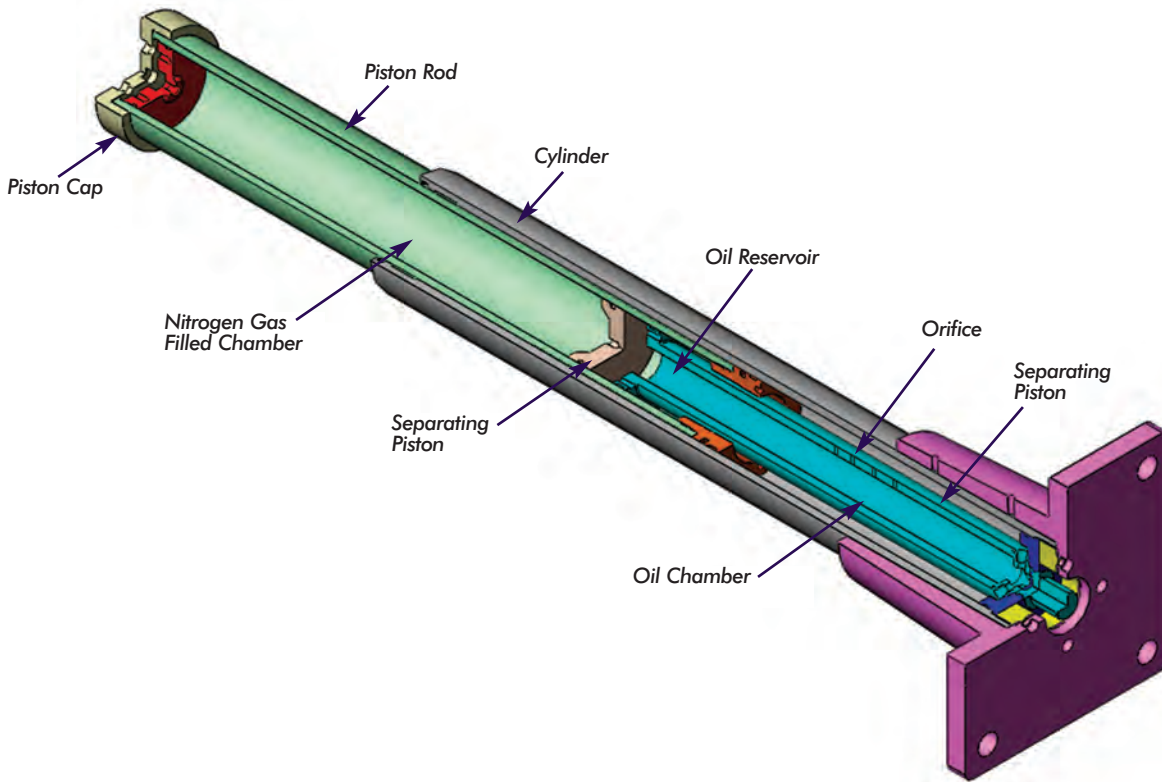

ITT Enidine's Heavy Industry Series (HI) buffers safely protect heavy machinery and equipment during the transfer of materials and movement of products. The large-bore, high-capacity buffers are individually designed to decelerate moving loads under various conditions and in compliance with industry mandated safety standards. Control of bridge cranes, trolley platforms, large container transfer and transportation safety stops are typical installation examples. Industry-proven design technologies, coupled with the experience of a globally installed product base, ensure deliverable performance that exceeds customer expectations.

Prior to HI Series buffer manufacture, computer-simulated response curves are generated to model actual conditions, verify product performance, confirm damping characteristics and generate unique custom-orificed designs that accommodate multi-condition or specific damping requirements.

Characteristics of the HI Series include a nitrogen-charged return system that allows for soft deceleration and positive return in a maintenance-free package. The oversize bore area results in optimal energy absorption capabilities and increased internal safety factors. State-of-the-art testing facilities ensure integrity of design and product performance.

Ordering Example

Mounting bracket flange:
Standard: Rear or Front mount

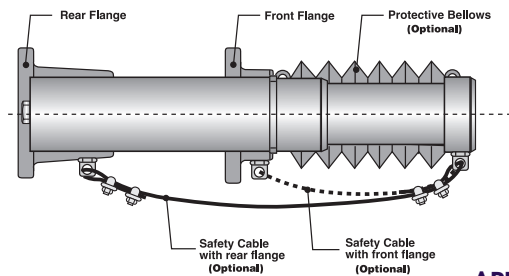

Example:

4

Select quantity

HI 120 x 100

Select HI Series model from Engineering Data Chart

FR

Select mounting method
• FF (Flange Front)
• FR (Flange Rear)

B

Additional Options
• B Protective Bellows
• C Safety cable

APPLICATION DATA

Required for all models:

- Vertical/Horizontal Motion
- Weight
- Impact Velocity
- Propelling Force (if any)
- Cycles/Hour
- Temperature/Environment
- Applicable Standards

HI 50 x 50 → HI 120 x 1000 Series

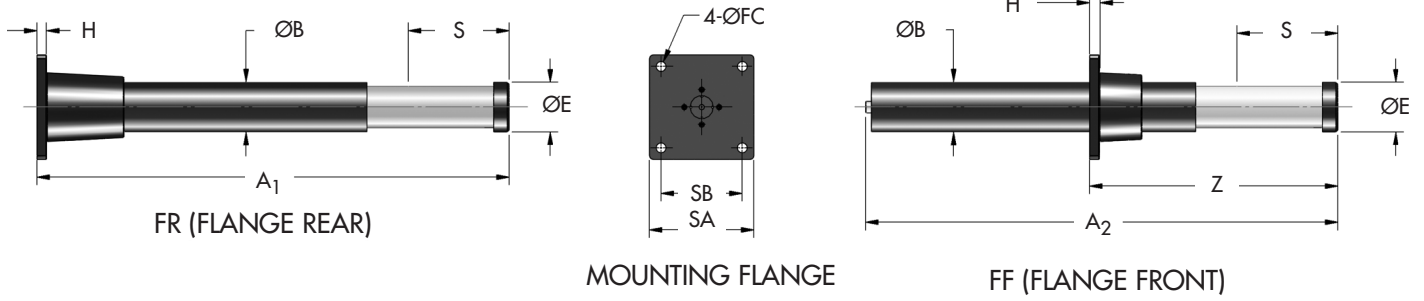

Catalog No./ Model	S Stroke in. (mm)	Max. Energy/cycle in.-lbs. (Nm)	Max. Shock Force lbs. (kN)	Return Force		Weight lbs. (Kg)	A ₁ in. (mm)	A ₂ in. (mm)	Z in. (mm)	H in. (mm)	ØB in. (mm)	SA in. (mm)	SB in. (mm)	ØFC in. (mm)	BOLT SIZE in. (mm)	ØE in. (mm)
				Extension lbs. (kN)	Compression lbs. (kN)											
HI 50 x 50	2 (50)	26,500 (3 000)	15,700 (70)	120 (0,5)	710 (3,2)	11 (5)	10.3 (262)	-	-	0.6 (15)	2.56 (65)	3.94 (100)	2.76 (70)	0.57 (14,5)	1/2 (M14)	2.28 (58)
HI 50 x 100	3.9 (100)	55,500 (6 200)	15,700 (70)	70 (0,3)	140 (0,6)	20 (9)	15.4 (392)	-	-	0.6 (15)	2.56 (65)	3.94 (100)	2.76 (70)	0.57 (14,5)	1/2 (M14)	2.28 (58)
HI 85 x 50	2 (50)	60,200 (6 800)	36,000 (160)	225 (1,0)	430 (1,9)	36 (16)	12.8 (324)	-	-	0.6 (15)	3.35 (85)	5.04 (128)	3.50 (89)	0.79 (20)	3/4 (M18)	3.11 (79)
HI 85 x 100	3.9 (100)	120,500 (13 600)	36,000 (160)	225 (1,0)	1,800 (8,0)	49 (22)	16.7 (424)	-	-	0.6 (15)	3.35 (85)	5.04 (128)	3.50 (89)	0.79 (20)	3/4 (M18)	3.11 (79)
HI 100 x 50	2 (50)	88,500 (10 000)	52,800 (235)	370 (1,65)	4,050 (18,0)	36 (16)	11.9 (302)	11.9 (301)	6.9 (175)	0.8 (20)	3.94 (100)	5.91 (150)	4.72 (120)	0.73 (18,5)	5/8 (M16)	3.90 (99)
HI 100 x 100	3.9 (100)	177,000 (20 000)	52,800 (235)	370 (1,65)	4,050 (18,0)	49 (22)	18.9 (479)	18.6 (473)	9.7 (245)	0.8 (20)	3.94 (100)	5.91 (150)	4.72 (120)	0.73 (18,5)	5/8 (M16)	3.90 (99)
HI 100 x 150	5.9 (150)	265,500 (30 000)	52,800 (235)	370 (1,65)	4,050 (18,0)	62 (28)	24.3 (618)	24.1 (612)	11.8 (300)	0.8 (20)	3.94 (100)	5.91 (150)	4.72 (120)	0.73 (18,5)	5/8 (M16)	3.90 (99)
HI 100 x 200	7.9 (200)	354,000 (40 000)	52,800 (235)	370 (1,65)	4,050 (18,0)	71 (32)	29.8 (756)	29.5 (750)	15.4 (390)	0.8 (20)	3.94 (100)	5.91 (150)	4.72 (120)	0.73 (18,5)	5/8 (M16)	3.90 (99)
HI 100 x 400	15.7 (400)	708,060 (80 000)	52,830 (235)	370 (1,65)	4,050 (18,0)	101 (46)	53.1 (1 349)	53.0 (1 345)	25.4 (645)	0.8 (20)	3.94 (100)	5.91 (150)	4.72 (120)	0.73 (18,5)	5/8 (M16)	3.90 (99)
HI 100 x 500	19.7 (500)	831,900 (94 000)	52,800 (235)	370 (1,65)	4,050 (18,0)	115 (52)	- (1 616)	63.6 (890)	35.0 (890)	0.8 (20)	3.94 (100)	5.91 (150)	4.72 (120)	0.73 (18,5)	5/8 (M16)	3.90 (99)
HI 100 x 600	23.6 (600)	991,200 (112 000)	50,000 (220)	370 (1,65)	4,050 (18,0)	128 (58)	- (1 888)	74.3 (1 040)	40.9 (1 040)	0.8 (20)	3.94 (100)	5.91 (150)	4.72 (120)	0.73 (18,5)	5/8 (M16)	3.90 (99)
HI 100 x 800	31.5 (800)	1,200,000 (136 000)	45,000 (200)	370 (1,65)	4,050 (18,0)	152 (69)	- (2 426)	95.5 (1 345)	53.0 (1 345)	0.8 (20)	3.94 (100)	5.91 (150)	4.72 (120)	0.73 (18,5)	5/8 (M16)	3.90 (99)
HI 120 x 100	3.9 (100)	283,200 (32 000)	84,300 (375)	630 (2,8)	11,250 (50,0)	75 (34)	18.5 (471)	18.4 (467)	10.6 (270)	0.8 (20)	4.72 (120)	8.66 (220)	6.69 (170)	1.03 (26,5)	1 (M24)	5.0 (127)
HI 120 x 150	5.9 (150)	424,800 (48 000)	84,300 (375)	630 (2,8)	11,250 (50,0)	86 (39)	23.5 (597)	23.3 (593)	13.0 (330)	0.8 (20)	4.72 (120)	8.66 (220)	6.69 (170)	1.03 (26,5)	1 (M24)	5.0 (127)
HI 120 x 200	7.9 (200)	566,400 (64 000)	84,300 (375)	630 (2,8)	11,250 (50,0)	95 (43)	28.5 (724)	28.3 (720)	15.4 (390)	0.8 (20)	4.72 (120)	8.66 (220)	6.69 (170)	1.03 (26,5)	1 (M24)	5.0 (127)
HI 120 x 300	11.8 (300)	831,900 (94 000)	84,300 (375)	630 (2,8)	11,250 (50,0)	117 (53)	38.3 (973)	38.1 (969)	20.5 (520)	0.8 (20)	4.72 (120)	8.66 (220)	6.69 (170)	1.03 (26,5)	1 (M24)	5.0 (127)
HI 120 x 400	15.7 (400)	1,106,300 (125 000)	84,300 (375)	630 (2,8)	11,250 (50,0)	192 (87)	48.2 (1 225)	48.1 (1 221)	26.8 (680)	1.0 (25)	4.72 (120)	8.66 (220)	6.69 (170)	1.03 (26,5)	1 (M24)	5.0 (127)
HI 120 x 600	23.6 (600)	1,663,900 (188 000)	84,300 (375)	630 (2,8)	11,250 (50,0)	232 (105)	- (1 725)	67.9 (915)	36.0 (915)	1.0 (25)	4.72 (120)	8.66 (220)	6.69 (170)	1.03 (26,5)	1 (M24)	5.0 (127)
HI 120 x 800	31.5 (800)	1,991,250 (225 000)	74,200 (330)	630 (2,8)	11,250 (50,0)	243 (110)	- (2 332)	91.8 (1 290)	50.8 (1 290)	1.0 (25)	4.72 (120)	8.66 (220)	6.69 (170)	1.03 (26,5)	1 (M24)	5.0 (127)
HI 120 x 1000	39.4 (1000)	2,301,000 (260 000)	67,400 (300)	630 (2,8)	11,250 (50,0)	256 (116)	- (2 836)	111.7 (1 360)	53.5 (1 360)	1.0 (25)	4.72 (120)	8.66 (220)	6.69 (170)	1.03 (26,5)	1 (M24)	5.0 (127)

Heavy Industry Shock Absorbers

HI Series

HI 130 x 250 → HI 150 x 1000 Series

Technical Data

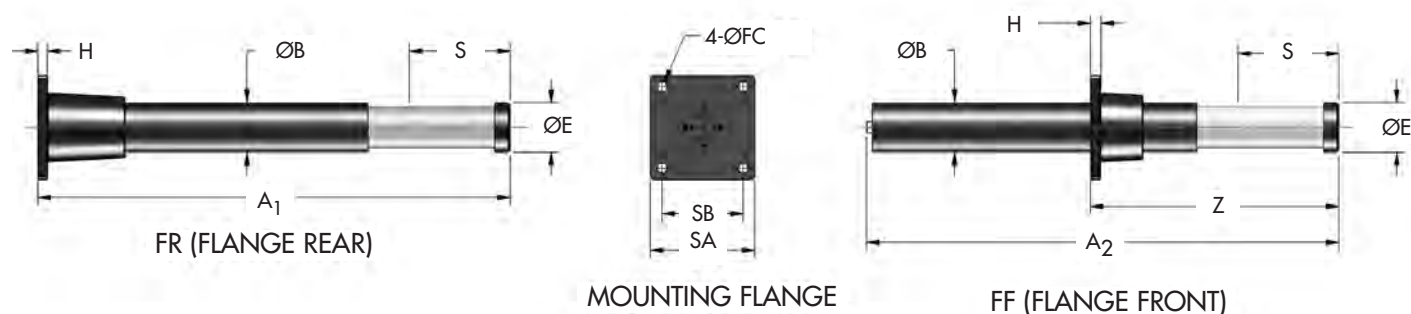

Catalog No./ Model	S Stroke in. (mm)	Max. Energy/cycle in.-lbs. (Nm)	Max. Shock Force lbs. (kN)	Return Force		Weight lbs. (Kg)	A ₁ in. (mm)	A ₂ in. (mm)	Z in. (mm)	H in. (mm)	ØB in. (mm)	SA in. (mm)	SB in. (mm)	ØFC in. (mm)	BOLT SIZE in. (mm)	ØE in. (mm)
				Extension lbs. (kN)	Compression lbs. (kN)											
HI 130 x 250	9.8 (250)	885,000 (100 000)	106,800 (475)	725 (3,2)	1,300 (50,0)	159 (72)	35.3 (897)	35.2 (894)	21.5 (545)	1.0 (25)	5.12 (130)	10.63 (270)	8.27 (210)	1.03 (26,5)	1 (M24)	5.08 (129)
HI 130 x 300	11.8 (300)	1,062,000 (120 000)	106,800 (475)	720 (3,2)	1,300 (50,0)	175 (79)	40.5 (1 029)	40.4 (1 025)	23.8 (605)	1.0 (25)	5.12 (130)	10.63 (270)	8.27 (210)	1.03 (26,5)	1 (M24)	5.08 (129)
HI 130 x 400	15.7 (400)	1,416,100 (160 000)	106,800 (475)	720 (3,2)	1,300 (50,0)	199 (90)	50.9 (1 293)	50.8 (1 289)	28.9 (735)	1.0 (25)	5.12 (130)	10.63 (270)	8.27 (210)	1.03 (26,5)	1 (M24)	5.08 (129)
HI 130 x 600	23.6 (600)	1,858,500 (210 000)	89,900 (400)	720 (3,2)	10,000 (45,0)	263 (119)	- (1 917)	75.5 (1 917)	41.5 (1 055)	1.0 (25)	5.12 (130)	10.63 (270)	8.27 (210)	1.03 (26,5)	1 (M24)	5.08 (129)
HI 130 x 800	31.5 (800)	2,388,500 (270 000)	89,900 (400)	720 (3,2)	10,000 (45,0)	309 (140)	- (2 445)	96.3 (2 445)	53.0 (1 345)	1.0 (25)	5.12 (130)	10.63 (270)	8.27 (210)	1.03 (26,5)	1 (M24)	5.08 (129)
HI 150 x 115	4.5 (115)	548,700 (62 000)	145,000 (645)	1,125 (5,0)	14,750 (65,7)	124 (56)	20.3 (516)	20.2 (513)	12.6 (320)	1.0 (25)	5.91 (150)	10.63 (270)	8.27 (210)	1.03 (26,5)	1 (M24)	5.87 (149)
HI 150 x 150	5.9 (150)	725,700 (82 000)	145,000 (645)	1,125 (5,0)	14,750 (65,7)	130 (59)	23.9 (606)	23.7 (602)	14.0 (355)	1.0 (25)	5.91 (150)	10.63 (270)	8.27 (210)	1.03 (26,5)	1 (M24)	5.87 (149)
HI 150 x 400	15.7 (400)	1,947,000 (220 000)	145,000 (645)	1,125 (5,0)	14,000 (62,4)	216 (98)	49.5 (1 257)	49.0 (1 245)	28.0 (710)	1.0 (25)	5.91 (150)	10.63 (270)	8.27 (210)	1.03 (26,5)	1 (M24)	5.87 (149)
HI 150 x 500	19.7 (500)	2,433,900 (275 000)	145,000 (645)	1,125 (5,0)	17,000 (75,5)	243 (110)	- (1 498)	59.0 (1 498)	30.3 (770)	1.0 (25)	5.91 (150)	10.63 (270)	8.27 (210)	1.03 (26,5)	1 (M24)	5.87 (149)
HI 150 x 600	23.6 (600)	2,920,500 (330 000)	145,000 (645)	1,125 (5,0)	17,000 (75,5)	265 (120)	- (1 752)	69.0 (1 752)	34.4 (875)	1.0 (25)	5.91 (150)	10.63 (270)	8.27 (210)	1.03 (26,5)	1 (M24)	5.87 (149)
HI 150 x 800	31.5 (800)	3,965,100 (448 000)	144,000 (640)	1,125 (5,0)	15,250 (68,0)	364 (165)	- (2 363)	93.0 (2 363)	48.8 (1 240)	1.0 (25)	5.91 (150)	10.63 (270)	8.27 (210)	1.03 (26,5)	1 (M24)	5.87 (149)
HI 150 x 1000	39.4 (1000)	4,513,500 (510 000)	134,900 (600)	1,125 (5,0)	13,750 (61,0)	397 (180)	- (2 880)	113.4 (2 880)	62.8 (1 595)	1.0 (25)	5.91 (150)	10.63 (270)	8.27 (210)	1.03 (26,5)	1 (M24)	5.87 (149)



Construction Elevator Emergency Stops



Mining Applications



Refinery Material Handling Applications