

UCV[®] HM SERIES

ULTRA-HIGH PURITY,
METAL-DIAPHRAGM VALVES
FOR GAS DELIVERY SYSTEMS

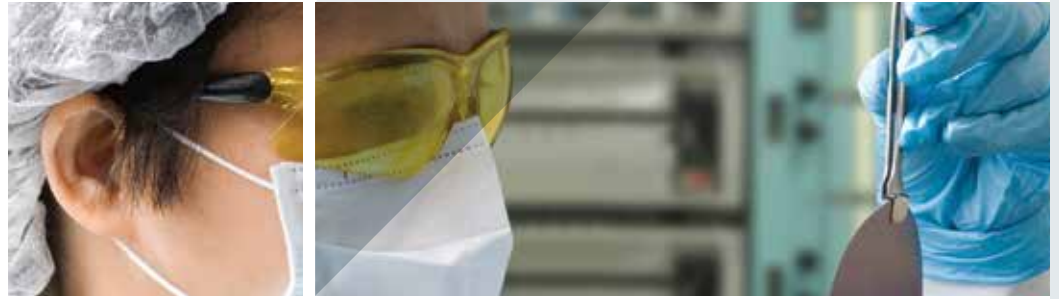

ULTRA CLEAN VALVES

HM & HMS SERIES

METAL DIAPHRAGM VALVES

The HM & HMS Valve Series includes Metal-Diaphragm, Ultra-Clean Valves, size 1/4". The HM & HMS Series is suitable for low and high-pressure applications in multi-port configurations (2- port, L-port, 3-port, 4-port). The valves can be operated manually or pneumatically. UCV valves are assembled, inspected, tested and packaged in a Class 10 Clean Room. Each valve is individually assembled and submitted to pressure testing, functionality tests and a helium leak test.



THE UCV HM & HMS SERIES SPECIFICATIONS

MATERIAL

UCV Series Valves meet the chemical composition and the mechanical properties of Stainless Steel 316L, according to the ASTM A276 specification. Chemical Composition: The body material of the UCV Series complies with SEMI F20 - the sulfur content is lower or equal to 0.01 percent.

MECHANICAL SIZE - DIMENSIONAL SPECIFICATION

UCV Series Valves meet the end-to-end length and overall envelope and comply with SEMATECH Technology Transfer 96063137-ENG.

PACKAGING

HAM-LET standard for packing the UCV Series Valves is a double bag. The inner bag contains ultra-pure nitrogen. All end fittings, threads and sealing surfaces are protected with a cap to prevent any damage.

ELECTROPOLISHED SURFACES - SURFACE FINISH

UCV Valves meet a surface defect level of maximum of 25 for any location with a maximum average of 15. This test is done in accordance with SEMASPEC 90120401-STD.

UCV Valves meet the Chromium Enhancement ratio of chromium-to-iron ratio of 2:1 and chromium oxide-to-iron oxide ratio of 3:1. This test is done in accordance with SEMASPEC 90120403-STD. UCV Valves meet the oxide layer depth and surface contamination of 20 angstroms after subtraction of the carbon layer. The carbon layer is 10 angstroms.

MAXIMUM SURFACE CONTAMINATIONS	
Element	Atomic Percentage
Carbon	30.0
Sulfur	1.0
Phosphorus	2.0
Silicon	1.5
Nitrogen	2.0

SURFACE ROUGHNESS

All wetted parts of the UCV Series Valves have an average surface roughness (Ra avg) of 5 microinch Ra, and maximum surface roughness (Ra max) of 10 microinch Ra, complying with ISO 4288.

HELIUM LEAK TEST

All UCV Series Valves are 100% helium leak tested. Helium-leak tests are performed using a helium-leak detector machine with a sensitivity of 0.1×10^{-10} atm cc He/sec. The standard leak-rate tests are listed below.

(Lower leak rates are optional on request)

Maximum Helium (He) leak ratings:

Inboard leak integrity 3×10^{-11} atm cc/sec. Complies with SEMI F1. Leak across the seat 1×10^{-9} atm cc/sec. This test is done in accordance with SEMASPEC 90120391B-STD (held for at least 15 seconds).

PARTICLES

The particles standard for UCV Series Valves is: less than 5 particles/ft³ for particles 0.1µm and 20 particles 0.02 µm for static and dynamic tests, according to SEMASPEC 90120390-STD.

MOISTURE TESTING

The standard moisture level is 20 ppbv H2O in Nitrogen baseline or less, within 2 hours after 2 ppmv spike for 1 minute at flow rate of 1.5 SLM or less, according to SEMASPEC 90120397-STD.

CLEANING

All CNC machined valve parts are cleaned to ensure that they are free of emulsion composition and residues involved in the machining process.

RELIABILITY

The valves demonstrate a MTTF of more than 1 million cycles for pneumatic valves and more than 100,000 cycles for manual valves, in accordance with SEMASPEC 90120395-STD and 90120390-STD.

HM SERIES

METAL DIAPHRAGM MANUAL HANDLE VALVES

The manually operated Ultra-Clean Diaphragm Valves are for high and low-pressure applications. The HM series is designed and manufactured per SEMI F-20 material specifications. The valves include a flexible port design with butt weld and face-seal end connections.



MATERIALS

Item No.	Part No.	Material
1*	Body	**Stainless steel, 316L Var or Vim/Var ⁽¹⁾
2*	Seat	**PTFE, Polyimide
3*	Seat Holder	**Stainless steel, 316L Var or Vim/Var ⁽¹⁾
4*	Diaphragm	Co-Cr-Ni Alloy
5	Act. Button	Stainless steel, AISI 304, ball AISI 440C
6	Act. Button Holder	Stainless steel, ASTM 630 H900
7	Handle & Stem Assembly	A6061T6, ASTM 630 H900

*Wetted parts ** Standard material

PANEL MOUNTING

Each manual valve has an upper panel mounting as well as a bottom mounting, as a standard. The upper panel mounting has a stainless steel nut, which requires a minimum width of 0.04" for panel.

For multi port valves, select the End Connection for each port, starting with port A, which is indicated by the sniffer hole in the body. Continue with the other ports (B,C,D).

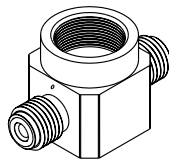
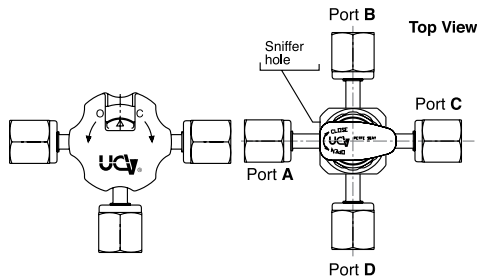

Male Face-Seal Ends

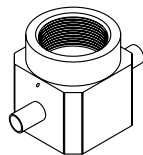

Butt Weld Ends

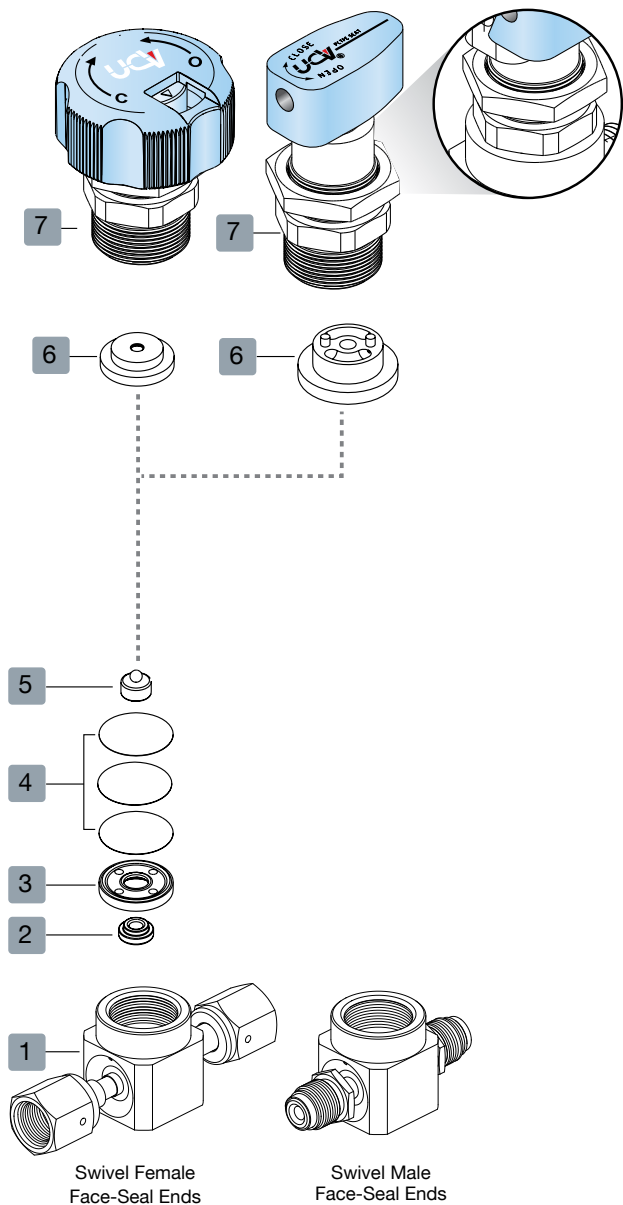

ULTRA CLEAN VALVES

⁽¹⁾ Per SEMI F20-0305

HM SERIES
**METAL DIAPHRAGM
 MANUAL HANDLE VALVES**

ULTRA CLEAN VALVES

UCV SPECIFICATIONS	
Structure	Direct-seal metal-diaphragm valve without seal packing Manually operated
Pressure	Vacuum to 300 psi (20 bar)
Temperature: Standard	14 to 140°F, -10 to 60°C (PCTFE Seat)
Available	14 to 302°F, -10 to 150°C (*Polyimide Seat)
Leakage: Inboard Leakage across the seat	≤ 3x10 ⁻¹¹ atm cc He/sec ≤ 1x10 ⁻⁹ atm cc He/sec
Particle	No particle detected above 0.1µm.
Operated	Round handle 3/4 turn Oval handle 1/4 turn
Connections	Face seal or tube weld
CV value - Low Pressure	0.3
Valve Lift	0.024", 0.6 mm
Direction	2 port straight, 2 port L, 3 port, 4 port
Surface Finish Ra (Ave)-Standard	5µin
Surface Finish Ra (Max)-Standard	10µin

*Used with Fluorocarbon FKM O-ring LP-Low pressure

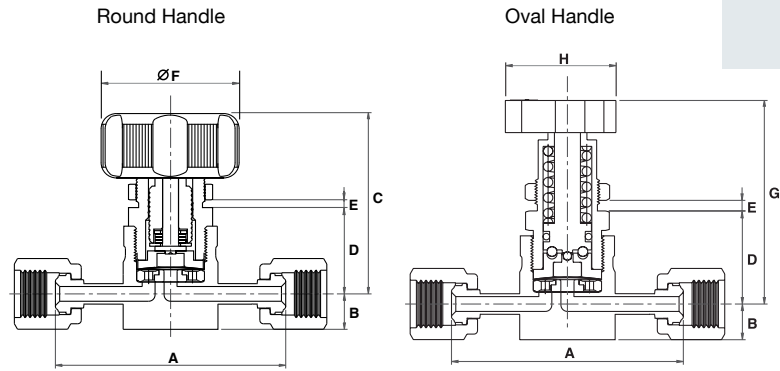
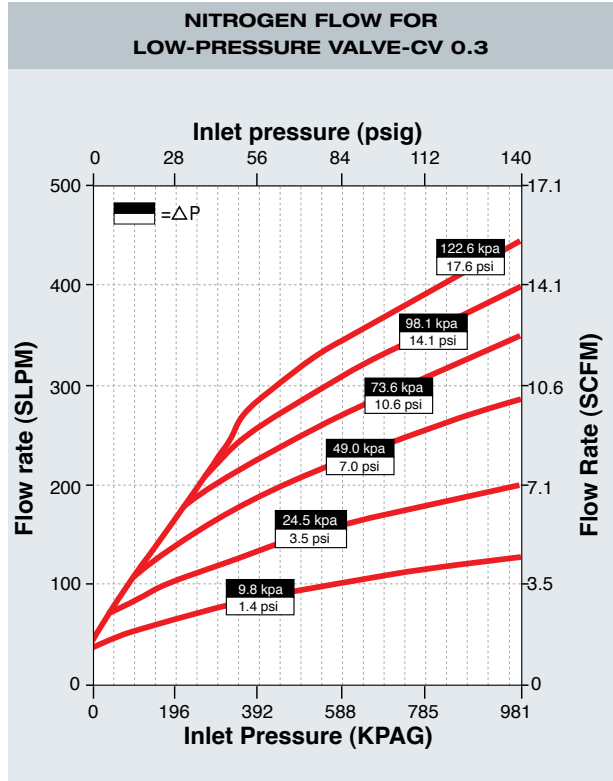

VALVE DIMENSIONS- inch, mm		A		B		C		D		E*		F		G		H	
Size	Connection	in	mm	in	mm	in	mm	in	mm	in	mm	in	mm	in	mm	in	mm
1/4"	Swivel Female Face-Seal	2.78	70.6	0.44	11.0	2.48	63.0	1.14	29.0	0.04	1.00	1.77	45.0	2.68	68.0	1.34	34.0
1/4"	Male Face-Seal	2.30	58.4	0.44	11.0	2.48	63.0	1.14	29.0	0.04	1.00	1.77	45.0	2.68	68.0	1.34	34.0
1/4"	Swivel Male Face-Seal	2.78	70.6	0.44	11.0	2.48	63.0	1.14	29.0	0.04	1.00	1.77	45.0	2.68	68.0	1.34	34.0
1/4"	Butt Weld	1.75	44.4	0.44	11.0	2.48	63.0	1.14	29.0	0.04	1.00	1.77	45.0	2.68	68.0	1.34	34.0

Dimensions are for reference only, and are subject to change.

*Minimum height for panel

HM SERIES

**METAL DIAPHRAGM
AIR-OPERATED VALVES**

The pneumatically operated Ultra-Clean Diaphragm Valve is for high and low-pressure applications. The HM series is designed and manufactured per SEMI F-20 material specifications, and it offers a flexible port design with butt-weld and face-seal end connections.



UCV SPECIFICATIONS

Structure	Direct-seal metal-diaphragm valve without seal packing Pneumatically operated
Pressure	Vacuum to 300 psi (20 bar)
Temperature: Standard	14 to 140°F, -10 to 60°C (PCTFE Seat)
Available	14 to 302°F, -10 to 150°C (*Polyimide Seat)
Leakage: Inboard Leakage	≤ 3x10 ⁻¹¹ atm cc He/sec
across the seat	≤ 1x10 ⁻⁹ atm cc He/sec
Particle	No particle detected above 0.1µm.
Operated	Pneumatic, NC/NO**
Connections	Face Seal or Tube Weld
CV value - Low Pressure	0.3
Valve Lift	0.6mm (0.024")
Direction	2-port straight, 2-port L, 3-port, 4-port
Surface Finish Ra (Ave)-Standard	5µin
Surface Finish Ra (Max)-Standard	10µin
Air Supply	60-90 psig , 4 - 6 bar
Air Connection	1/8" NPT

*Used with Fluorocarbon FKM O-ring **NC-Normally Closed LP-Low pressure
NO-Normally Open

MATERIALS

Item No.	Part No.	Material
1*	Body	**Stainless steel, 316L Var or Vim/Var ⁽¹⁾
2*	Seat	**PCTFE, Polyimide
3*	Seat Holder	**Stainless steel, 316L Var or Vim/Var ⁽¹⁾
4*	Diaphragm	Co-Cr-Ni Alloy
5	Act. Button	Stainless steel, AISI 304, ball AISI 440C
6	Act. Button Holder	Stainless steel, ASTM 630 H900
7	Actuator Assembly	A6061T6

*Wetted parts ** Standard material

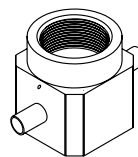
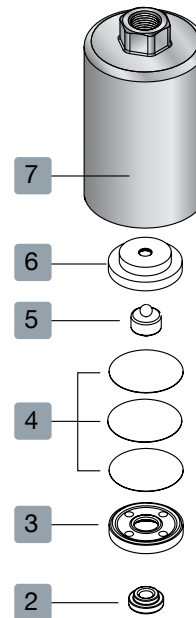

Butt Weld Ends

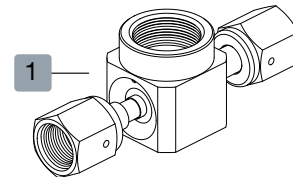

Swivel Female Face-Seal Ends

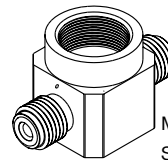

Male Face-Seal Ends

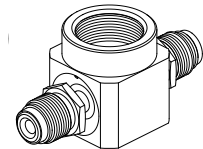

Swivel Male Face-Seal Ends

⁽¹⁾ Per SEMI F20-0305

**HM SERIES
METAL DIAPHRAGM
AIR OPERATED VALVES**

VALVE DIMENSIONS - INCH (MM)													
Size	Connection	A		B		C		D		E*		F	
		in	mm	in	mm	in	mm	in	mm	in	mm	in	mm
1/4"	Swivel Female Face-Seal	2.78	70.6	0.44	11.0	1.16	29.4	1.16	29.4	1.00	25.4	1.40	35.3
1/4"	Male Face-Seal	2.30	58.4	0.44	11.0	1.16	29.4	1.16	29.4	1.00	25.4	1.15	29.2
1/4"	Swivel Male Face-Seal	2.78	70.6	0.44	11.0	1.16	29.4	1.16	29.4	1.00	25.4	1.40	35.3
1/4"	Butt Weld	1.75	44.4	0.44	11.0	1.16	29.4	1.16	29.4	1.00	25.4	0.87	22.2

ACTUATOR DIMENSIONS - INCH (MM)					
Actuator type	I	∅J	K	Effective Area	Output Force
Low Pressure	2.86 (72.7)	1.33 (34)	3.29 (83.7)	1.58 in ²	550 psig
High Pressure	3.50 (89)	1.57 (40)	3.93 (100)	1.58 in ²	550 psig
AO-Position switch			3.78 (96)		

STANDARD PANEL MOUNTING FOR TWO-PORT STRAIGHT VALVE

- Optional, four threaded holes (two as standard).
- All the other valve types have standard four threaded holes.
- According to SEMATECH 96063137-ENG.

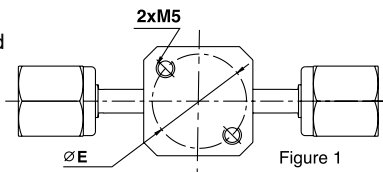

The M5 threaded mounting holes will accept 10-32 screws.

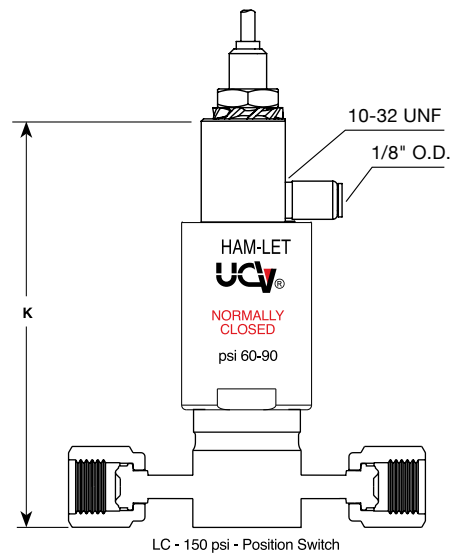
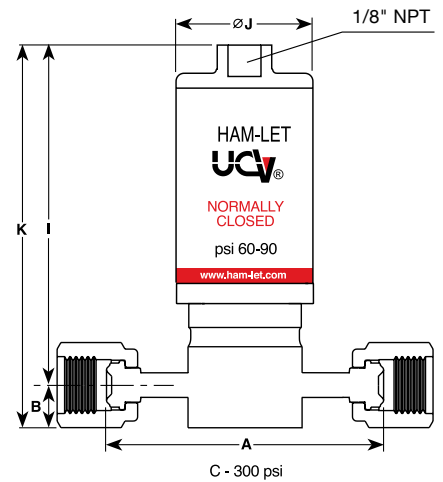
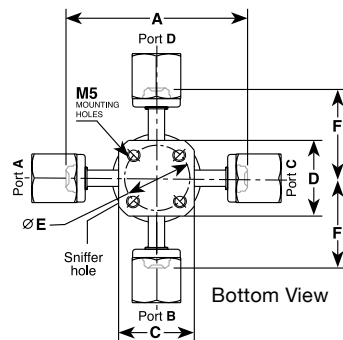
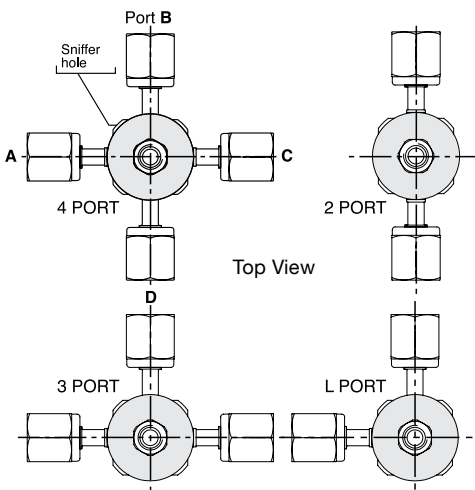

* The dimensions apply to pneumatic and manual valves. Dimensions are for reference only, and are subject to change.

ORDERING INFORMATION - HM SERIES

Valve Description Example:

HM	2	1 - 4	V	K	LR	BW 4 GF 4 - LS
Valve Series	Port Designator	Body Material		Actuation Device		End Size
HM - UCV Valves	0, 1, 2, 3, 4, 5	V - SS316L Var or Vim/Var ⁽¹⁾ (Bar Stock) Standard		LC - Air Operated N.C. 150 psi C - Air Operated N.C. 300 psi LO - Air Operated N.O. 150 psi O - Air Operated N.O. 300 psi LR - Round Handle 3/4 turn 300 psi* LQ - Oval Handle 1/4 turn 300 psi		4 - 1/4" 6 - 3/8"* 8 - 1/2" 6mm*
				* Blue color is a standard Handle color can be delivered by request. NC-Normally close, NO- Normally open.		* BW, LL End connections only
Valve Type	Body Size	Seat Material	End Connection		Features	
2 - 2-Port Valve	4 - 1/4	K - PCTFE	BW - Butt Weld GF - Swivel female Face-seal** GM - Swivel male Face-seal** M - Male Face-seal** LL - Let-Lok®		LD - Locking Device ISLT - LOTO handle LS - For limit switch indicator on AOP Valve, contact your local HAM-LET representative	
3 - 3-Port Valve		S* - Polyimide				
4 - 4-Port Valve						
		K Standard, *Available				
** 1/4", 1/2" End connection size only						

ULTRA CLEAN VALVES

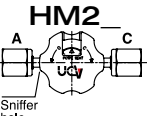
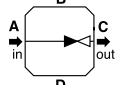
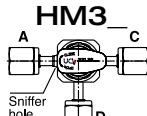
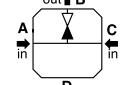
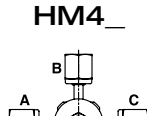
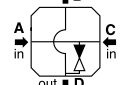
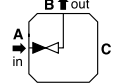
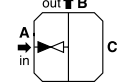
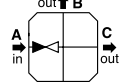
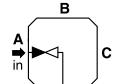
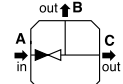
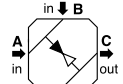
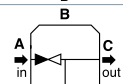
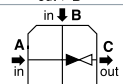
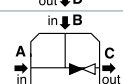
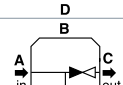
PORT DESIGNATOR - (TOP VIEW)								
Valve Configuration	Port Designator	Schematic Flow Chart	Valve Configuration	Port Designator	Schematic Flow Chart	Valve Configuration	Port Designator	Schematic Flow Chart
2 Port Valve HM2 	0		3 Port Valve HM3 	0		4 Port Valve HM4 	0	
	1 L-Port			1			1	
	2 L-Port			2			2	
				3			3	
				4				
				5				

⁽¹⁾ Per SEMI F20-0305

HMS SERIES SURFACE-MOUNT SERIES

The Ultra Clean Valves Series offer a surface mount body design. The surface mount design complies with SEMI PR 3.1 for 1.125" C-seal. HMS Series is manufactured according to UHP specifications of SEMI F-20 with manual and pneumatic operating mechanisms.



MATERIALS

Item No.	Part No.	Material
1	Body	Stainless steel, 316L Var or Vim/Var ⁽¹⁾
2	Seat	PCTFE, Polyimide
3	Seat Holder	Stainless steel, 316L Var or Vim/Var ⁽¹⁾
4	Diaphragm	Co-Cr-Ni Alloy
5	Actuation Device	Manual A6061T6
		Pneumatic A6061T6

UCV SPECIFICATIONS

Structure	Direct-seal, metal-diaphragm valve without seal packing, manually and pneumatically operated
Pressure	Vacuum to 150 psi (10 bar)
Operating Temperature: Standard	14 to 140°F, -10 to 60°C (PCTFE Seat)
	Available 14 to 302°F, -10 to 150°C *(Polyimide Seat)
Leakage: Inboard Leakage across the seat	≤ 3x10 ⁻¹¹ atm cc He/sec
	≤ 1x10 ⁻⁹ atm cc He/sec
Particle	No particles detected above 0.1µm.
CV value	0.3
Surface Finish Ra (Ave)-Standard	5µin
Actuator Air Supply (Pneumatic)	60-90 psig, 4 - 6 bar
Air Connection (Pneumatic)	Thread 10-32 UNF

* Used with Fluorocarbon FKM O-ring for actuation device

ACTUATION DEVICE - MARKING

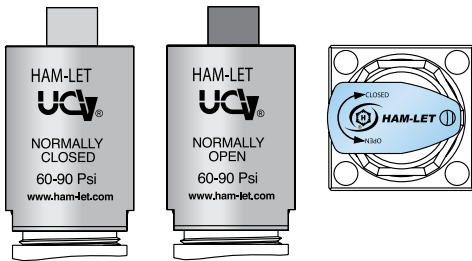

Warning!

The system designer and user have the sole responsibility for selecting products suitable for their special application requirements, ensuring their safe and trouble-free installation, operation, and maintenance. Application details, material compatibility and product ratings should all be considered for each selected product. Improper selection, installation or use of products can cause property damage or personal injury.

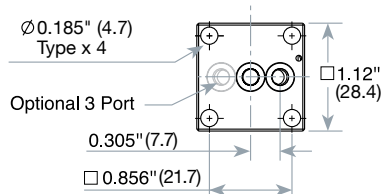
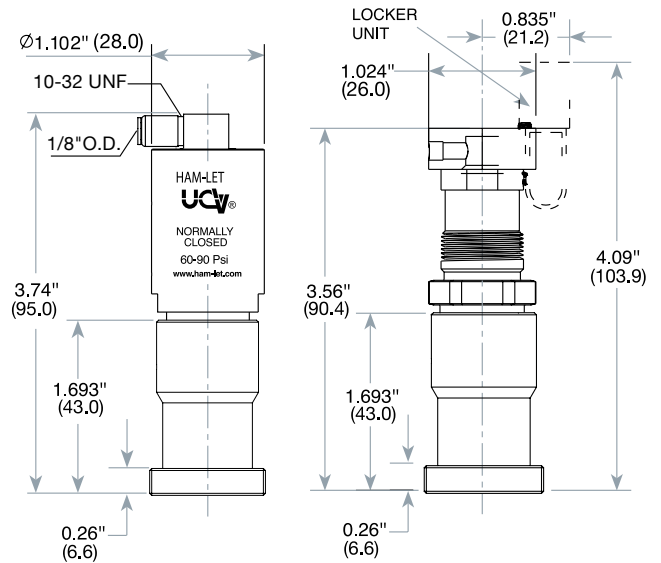
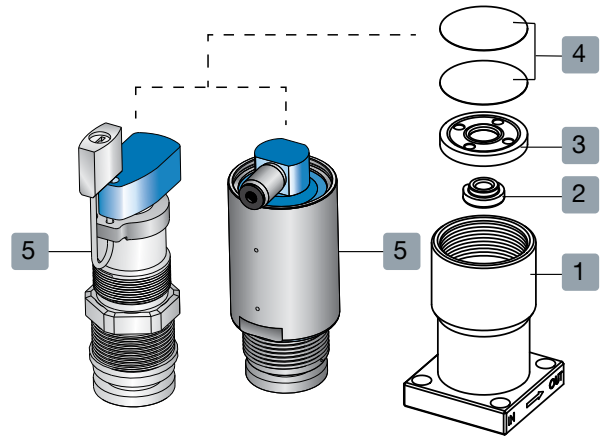

- The dimensions apply to pneumatic and manual valves.
- Dimensions are for reference only, and are subject to change.

⁽¹⁾ Per SEMI F20-0305

HMSC COMPACT SURFACE-MOUNT SERIES

The Ultra Clean Valve Series offer a surface mount body design. The surface mount design complies with SEMI PR 3.1 for 1.125" C-seal. This valve is a low profile body design with an Integral Safety Lockout Tag-out (ISLT[®]) handle. (Pat. No. 165393).



MATERIALS

Item No.	Part No.	Material
1	Body	Stainless steel, 316L Var or Vim/Var ⁽¹⁾
2	Seat	PCTFE, Polyimide
3	Diaphragm	Co-Cr-Ni Alloy
4	Actuation Device	Manual A6061T6
		Pneumatic A6061T6

UCV SPECIFICATIONS

Pressure	Vacuum to 150 psi (10 bar)
Operating Temperature: Standard	14 to 140°F, -10 to 60°C (PCTFE Seat)
	Available 14 to 302°F, -10 to 150°C *(Polyimide Seat)
Leakage: Inboard Leakage	≤ 3x10 ⁻¹¹ atm cc He/sec
	Across the seat ≤ 1x10 ⁻⁹ atm cc He/sec
Particle	No particles detected above 0.1µm.
CV value	0.3
Surface Finish Ra (Ave)-Standard	5µin
Actuator Air Supply (Pneumatic)	60-90 psig, 4 - 6 bar
Air Connection (Pneumatic)	Thread 10-32 UNF

* Used with Fluorocarbon FKM O-ring for actuation device

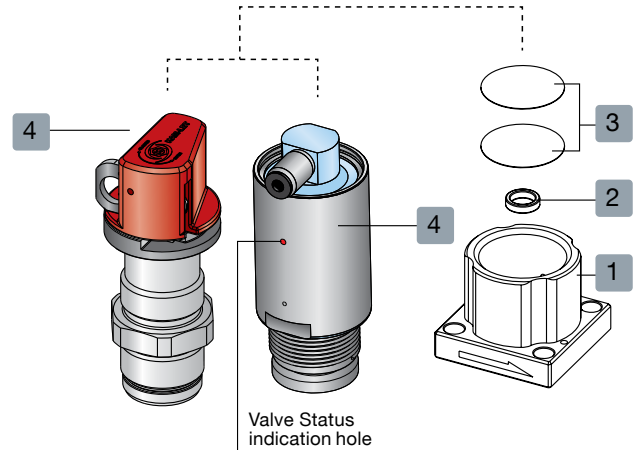

ACTUATION DEVICE - MARKING

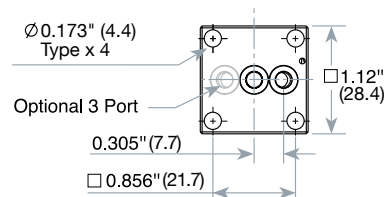
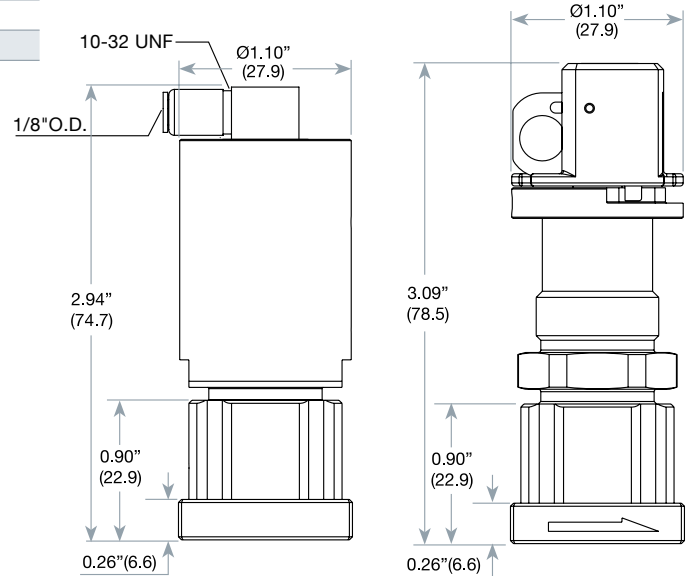
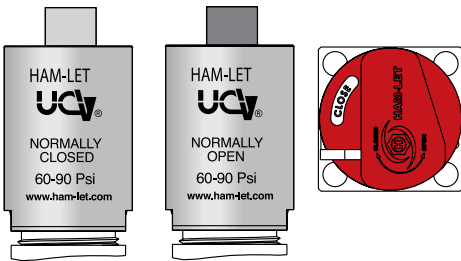

- The dimensions apply to pneumatic and manual valves.
- Dimensions are for reference only, and are subject to change.

Warning!

The system designer and user have the sole responsibility for selecting products suitable for their special application requirements, ensuring their safe and trouble-free installation, operation, and maintenance. Application details, material compatibility and product ratings should all be considered for each selected product. Improper selection, installation or use of products can cause property damage or personal injury.

⁽¹⁾ Per SEMI F20-0305

ORDERING INFORMATION - HMS & HMSC

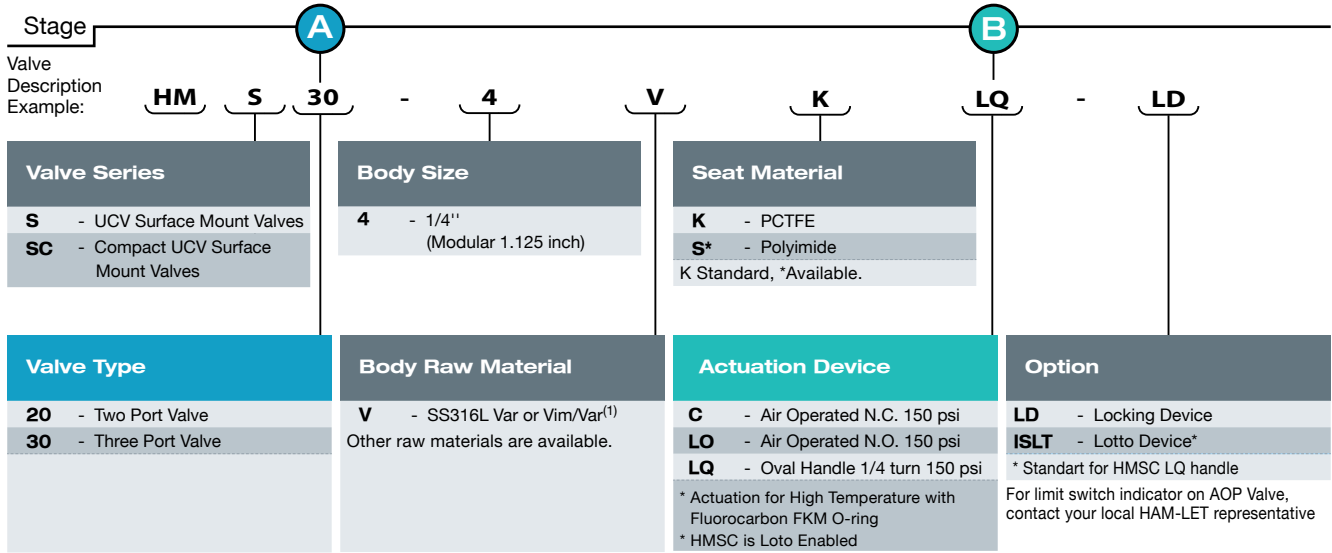

ORDERING EXAMPLES					
	HMS30 - 4VSLQ -LD			HMS20 - 4VKC	
Valve Type - Stage A	30	Surface Mounted Valve - Three Port		20	Surface Mounted Valve - Two Port
Body Size	4	1/4" (Modular 1.125 inch)		4	1/4" (Modular 1.125 inch)
Body Material	V	SS316L Var or Vim/Var ⁽¹⁾		V	SS316L Var or Vim/Var ⁽¹⁾
Seat Material	S	Polyimide		K	PCTFE
Actuation Device - Stage B	LQ	Oval Handle 1/4 turn 150 psi		C	Air Operated N.C. 150 psi
Features	LD	Locking Device			

⁽¹⁾ Per SEMI F20-0305

TWO STAGES FOR ORDERING SURFACE-MOUNT VALVES **A** **B**

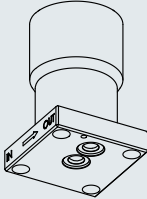
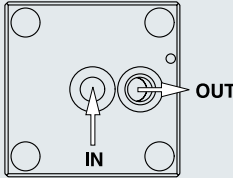
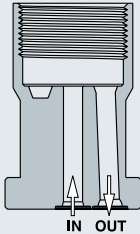
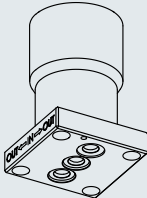
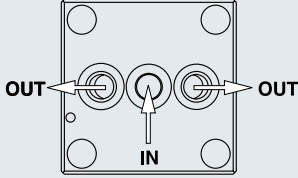
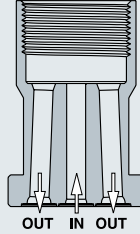
STAGE A VALVE TYPE			
	Flow Direction Body View	Schematic Flow Chart	Flow Direction
HMS(C)20 Two Port Valve			
HMS(C)30 Three Port Valve			

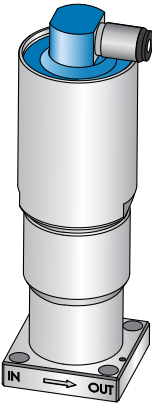
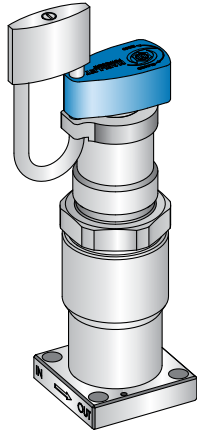
STAGE B ACTUATION DEVICE*					
Actuation Type	Actuation Mode	Description	Actuation Type	Actuation Mode	Description
Pneumatic	C	Normally Closed 150 psi Normally Opened 150 psi  * Blue Actuation Cap indicates Normally Closed. ** Red Actuation Cap indicates Normally Opened.	Manual	LD	Oval Handle 1/4 turn 150 psi with Locking Device  * The Actuation Device for the manual valve does not include: locking device or locker unit as standard.

HMC SERIES

COST EFFICIENT ULTRA CLEAN METAL DIAPHRAGM VALVE FOR GENERAL PURPOSE

Metal Diaphragm Valves

- Compact design
- Manual 3/4 turn handle and position indicator (open/close), 300 PSI
- Safety clip; Locking device for manual round 3/4 turn handle
- Pneumatically actuated, Normally Closed and Normally Open version, 150 PSI
- Electropolished surfaces as standard
- Standard panel mounting



PART NUMBER / DIMENSIONS

Actuation type	End Connection	A	B	C	D	E	G
		mm	mm	mm	mm	mm	mm
Air Operated NC / NO	Butt Weld 1/4	44.4	56.9	32			
	Male HTC 1/4	58.4					
	Let-Lok 1/4	64.7*					
	Female HTC 1/4	70.6					
	Swivel Male HTC 1/4	70.6					
Round 3/4 Turn Handle	Butt Weld 1/4	44.4	51.4	45	11	25.4	29.4
	Male HTC 1/4	58.4					
	Let-Lok 1/4	64.7*					
	Female HTC 1/4	70.6					
	Swivel Male HTC 1/4	70.6					
Oval Directional 1/4 Turn Handle	Butt Weld 1/4	44.4	68	34			
	Male HTC 1/4	58.4					
	Let-Lok 1/4	64.7*					
	Female HTC 1/4	70.6					
	Swivel Male HTC 1/4	70.6					

* LET-LOK® configuration length including nuts and ferrules fingers tight

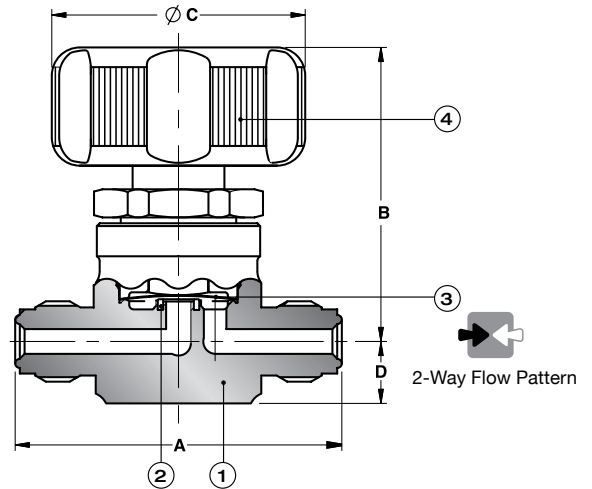

SPECIFICATIONS

Size	Pressure	Temp.	Cv	Leak Rates	
				Inboard	Across Seat
1/4	Vacuum to 300 psi (20.7 bar)	-10~60°C 14~140°F	0.25	≤ 3 X10 ⁻¹¹ Atm cc/sec Helium	≤ 3 X10 ⁻⁹ Atm cc/sec Helium

STRUCTURE

Parts	Material
① Body	316L Stainless Steel / SS316L Var or Vim/Var ⁽¹⁾
② Seat	PCTFE
③ Diaphragm	Co-Cr-Ni Alloy
④ Handle/Act	Aluminum Anodize

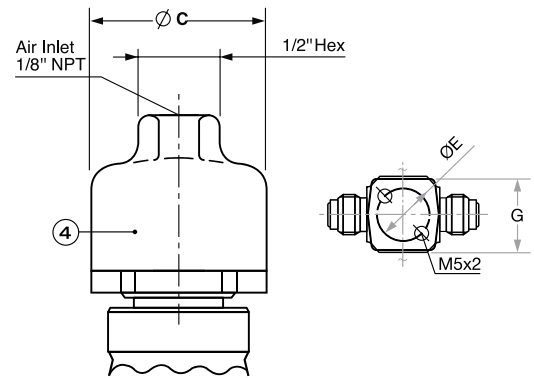

ORDERING INFORMATION

Valve Description Example:	HMC	20	4	L	K	ER	M4
Valve Type	Body Size	Body Material	Seat Material	Actuation Type	End Connection		
2 2-port	4 - 1/4	L - St.St. 316L A - SS316L Var or Vim/Var ⁽¹⁾	K - PCTFE	ER - Round 3/4 turn Handle 300 psi EC - Air operated Normally Close 150 psi EO - Air operated Normally Open 150 psi EQ - Oval Directional 300 psi	M4 - 1/4 Male Face Seal BW4 - 1/4 Tube Butt-Weld LL4 - 1/4 Let-Lok GM4 - 1/4 Swivel Male Face Seal GF4 - 1/4 Swivel Female Face Seal		

HMC20 is standard. For other configuration contact HAM-LET customer service

The system designer and user have the sole responsibility for selecting products suitable for their special application requirements, ensuring their safe and trouble-free installation, operation, and maintenance. Application details, material compatibility and product ratings should all be considered for each selected product. Improper selection, installation or use of products can cause property damage or personal injury.

⁽¹⁾ Per SEMI F20-0305

2LN SERIES (HYBRID)

AIR OPERATED, MANUAL OVERRIDE

Metal Diaphragm Valves

Surface-mount models from the Ultra Clean Valve specifications are ready for SEMI PR 3.1, 1.125" C seal connections. These valves implement Cv 0.3 for their compact designs.



VALVE DIMENSIONS - INCH (MM)

Part Number/ep	Size	End Connection	A		B		C		D		E		F		G		H		J	
			in	mm	in	mm	in	mm	in	mm	in	mm	in	mm	in	mm	in	mm	in	mm
2LNS4C-CM2-HB	1/4"	1.125"	0.89	22.8	4.4	111.0	0.25	6.6	1.12	28.4	0.30	7.75	0.50	12.7	0.19	5	0.85	21.74	0.17	4.4

SPECIFICATIONS

Size	Pressure	Temp.	Cv	Leak Rates	
				Inboard	Across Seat
1/4	1MPa (150 psi)	-10 60°C	0.3	3 X 10 ⁻¹² Pa ¹ m ³ /sec Helium	3 X 10 ⁻¹⁰ Pa ¹ m ³ /sec Helium

STRUCTURE

Parts	Material
① Body	316L Stainless Steel
② Seat	PCTFE/PI (Polyimide)
③ Diaphragm	Co-Cr-Ni Alloy
④ Handle/Act	Aluminum

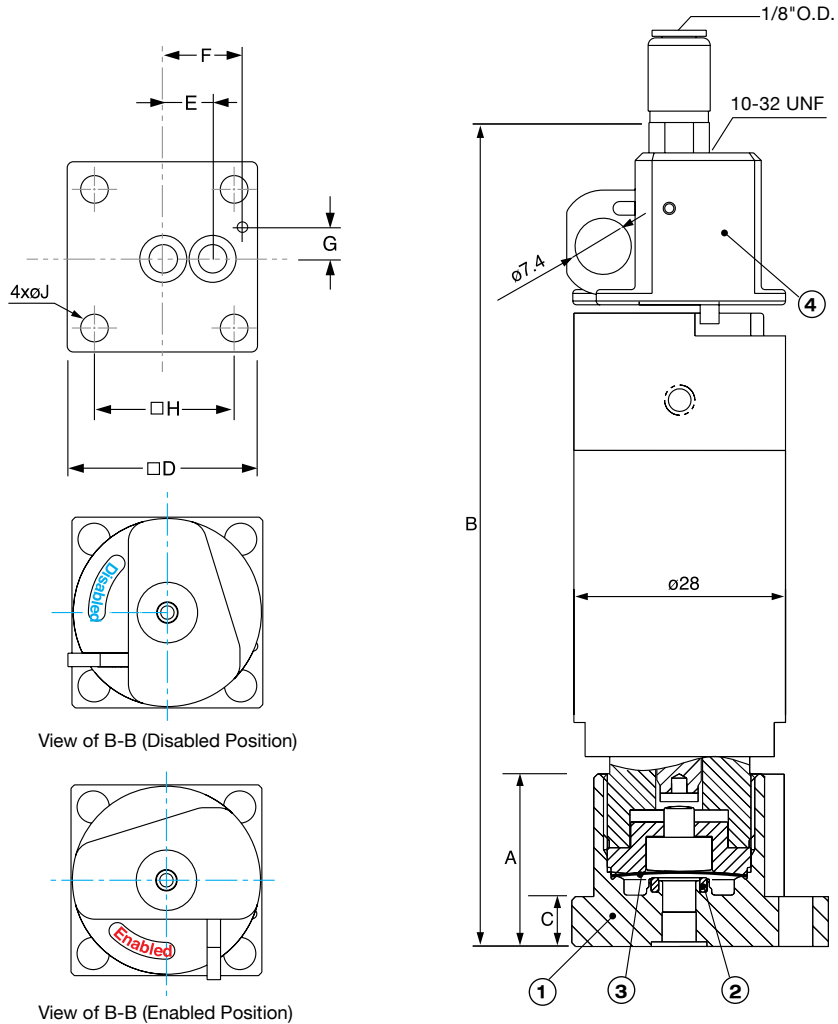

ORDERING INFORMATION

2LNS4C-CM2-HB

The system designer and user have the sole responsibility for selecting products suitable for their special application requirements, ensuring their safe and trouble-free installation, operation, and maintenance. Application details, material compatibility and product ratings should all be considered for each selected product. Improper selection, installation or use of products can cause property damage or personal injury.

HD SERIES

ECONOMIC DIAPHRAGM VALVES

The HD series of manual and pneumatically operated diaphragm valves provides a cost effective solution for low pressure applications up to 300 psi (20 bar). This unique diaphragm valve series was specifically designed to meet the pressure, finish and cleanliness requirements of Photo Voltaic panels and LED manufacturing as well as several Semiconductor applications. The HD20 valve series is the latest addition to HAM-LET high quality and economic solutions.



HD20 SERIES SPECIFICATIONS

Structure	Direct-seal metal-diaphragm valve manually & pneumatic operated
Pressure: Manual Aluminum round handle ¼ turn	300 psi (20bar)
Air Operated	150psi (10bar)
Air Operated	300psi (20bar)
Temperature	14 to 140°F, -10 to 60°C (PCTFE Seat)
Leakage: Inboard Leakage	Less Than 3x10 ⁻¹¹ atm cc He/sec
Across the seat	Less Than 1x10 ⁻⁹ atm cc He/sec
End Connections	Swivel Female Face-Seal, Male Face Seal, Swivel Male Face Seal, Butt-weld, Let-Lok
Cv value	0.3 (for high flow available Cv = 0.42)
Direction	2 port straight
Surface Finish Ra (Ave)-Standard	10µin, No Electro Polish



AOP 150 psi



AOP 300 psi

STANDARD CONFIGURATION DIMENSIONS:

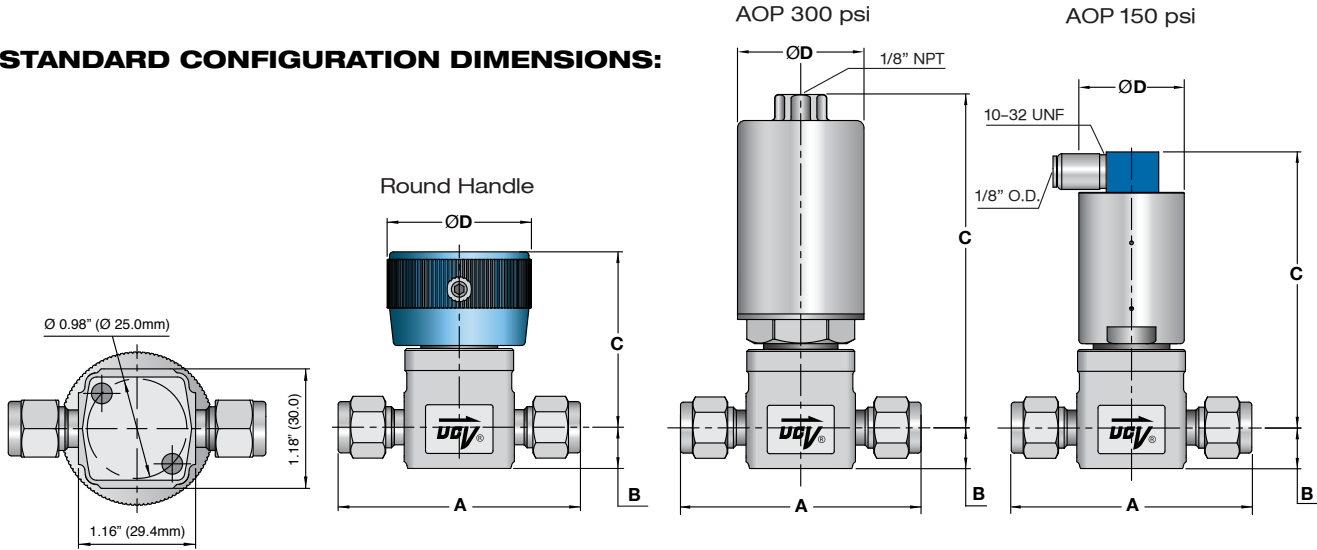

End Connections	Description	A		B		C		D	
		mm	inch	mm	inch	mm	inch	mm	inch
Swivel Female Face-Seal	HD20-4LKR-GF4	70.6	2.78	11	0.43	46.8	1.84	38	1.5
	HD20-4LKLC-GF4					72.2	2.84	28.2	1.11
	HD20-4LKC-GF4					90	3.54	34	1.34
Swivel Male Face-Seal	HD20-4LKR-GM4	70.6	2.78			46.8	1.84	38	1.5
	HD20-4LKLC-GM4					72.2	2.84	28.2	1.11
	HD20-4LKC-GM4					90	3.54	34	1.34
Male Face-Seal	HD20-4LKR-M4	58	2.28			46.8	1.84	38	1.5
	HD20-4LKLC-M4					72.2	2.84	28.2	1.11
	HD20-4LKC-M4					90	3.54	34	1.34
Buttweld	HD20-4LKR-BW4	44.4	1.75			46.8	1.84	38	1.5
	HD20-4LKLC-BW4			72.2	2.84	28.2	1.11		
	HD20-4LKC-BW4			90	3.54	34	1.34		
Let-Lok®	HD20-4LKR-LL4	64.7	2.55	46.8	1.84	38	1.5		
	HD20-4LKLC-LL4			72.2	2.84	28.2	1.11		
	HD20-4LKC-LL4			90	3.54	34	1.34		

ORDERING INFORMATION HD SERIES

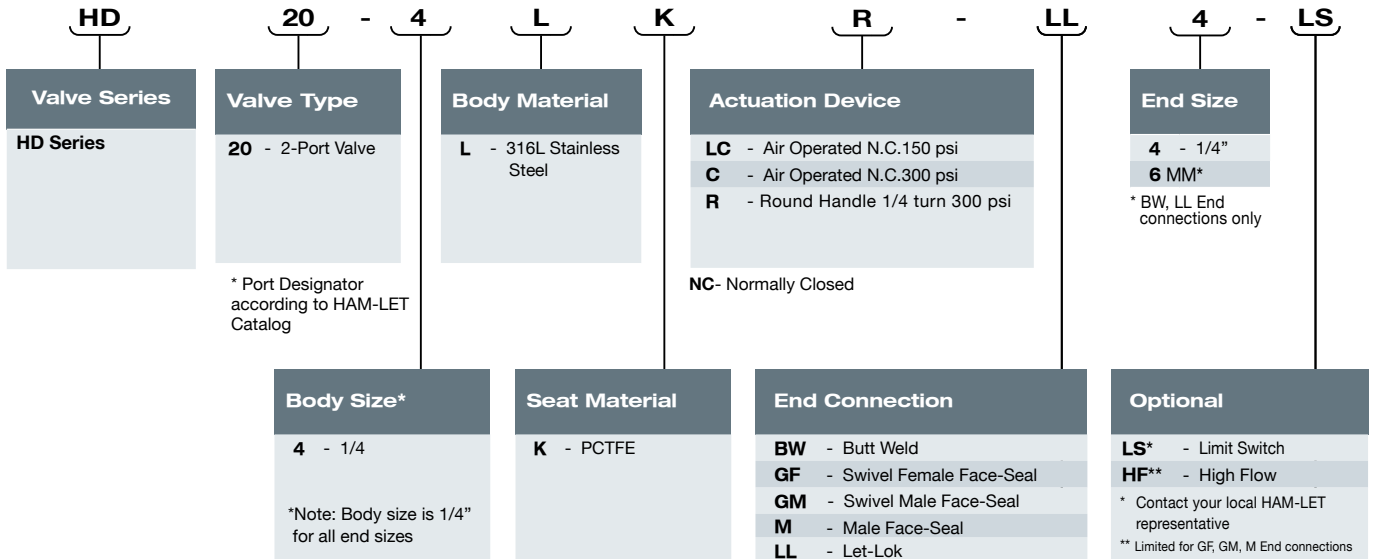

**HP SERIES
HIGH PRESSURE DIAPHRAGM VALVES**



HP20 SERIES SPECIFICATIONS

Structure	Direct-seal metal-diaphragm valve manually & pneumatic operated
Pressure	Vacuum to 3060 psi (210 bar)
Temperature	14 to 104°F, -10 to 60°C (PTFE Seat)
Leakage: Inboard Leakage	Less Than 3x10 ⁻¹¹ atm cc He/sec
Across the seat	Less Than 1x10 ⁻⁹ atm cc He/sec
Operated	Manual : Lever 1/4 turn Pneumatic : NC/NO
End Connections	Swivel Female Face-Seal, Male Face Seal, Swivel Male Face Seal, Buttweld, Let-Lok
CV Value	0.27
Direction	2 port straight, 2 port L, 3 port, 4 port
Surface Finish Ra (Ave)-Standard	5µin
Air Supply	60-90 psig, 4-6 bar
Air Connection	BSPT 1/8" (NPT 1/8" as an option)

**STANDARD CONFIGURATION DIMENSIONS:
MANUAL HANDLE & PNEUMATIC, NC/NO**

Bottom

Four mounting holes, M5 X 0.8 thread, 0.25" (6.5mm) deep, M5x0.8 holes are compatible with 10-32 mounting screws.

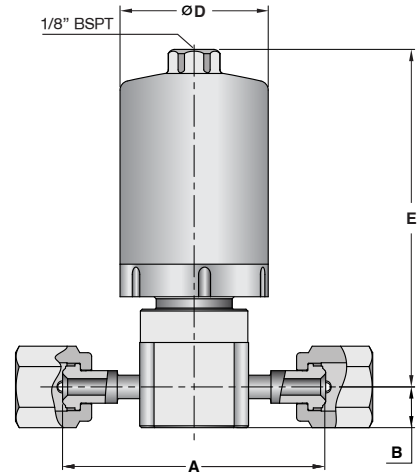
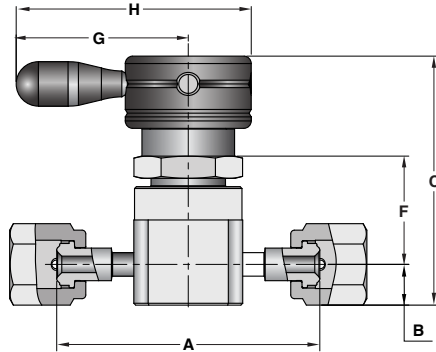
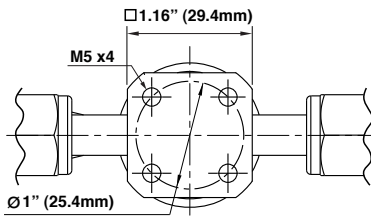

End Connections	Description	A	B	C	D	E	F	G	H
		mm (inch)	mm (inch)	mm (inch)	mm (inch)	mm (inch)	mm (inch)	mm (inch)	mm (inch)
Swivel Female Face-Seal	HP20-4VKHL-GF4	70.6 (2.78)	11 (0.43)	67.2 (2.65)	40 (1.57)	90 (3.54)	29.2 (1.15)	46.5 (1.83)	63.5 (2.5)
	HP20-4VKHC-GF4								
	HP20-4VKHO-GF4								
Male Face-Seal	HP20-4VKHL-M4	58.4 (2.3)	11 (0.43)	67.2 (2.65)	40 (1.57)	90 (3.54)	29.2 (1.15)	46.5 (1.83)	63.5 (2.5)
	HP20-4VKHC-M4								
	HP20-4VKHO-M4								
Swivel Male Face-Seal	HP20-4VKHL-GM4	70.6 (2.78)	11 (0.43)	67.2 (2.65)	40 (1.57)	90 (3.54)	29.2 (1.15)	46.5 (1.83)	63.5 (2.5)
	HP20-4VKHC-GM4								
	HP20-4VKHO-GM4								
Buttweld	HP-20-4VKHL-BW4	44.4 (1.75)	11 (0.43)	67.2 (2.65)	40 (1.57)	90 (3.54)	29.2 (1.15)	46.5 (1.83)	63.5 (2.5)
	HP20-4VKHC-BW4								
	HP20-4VKHO-BW4								

ORDERING INFORMATION HP SERIES

Valve Description Example:

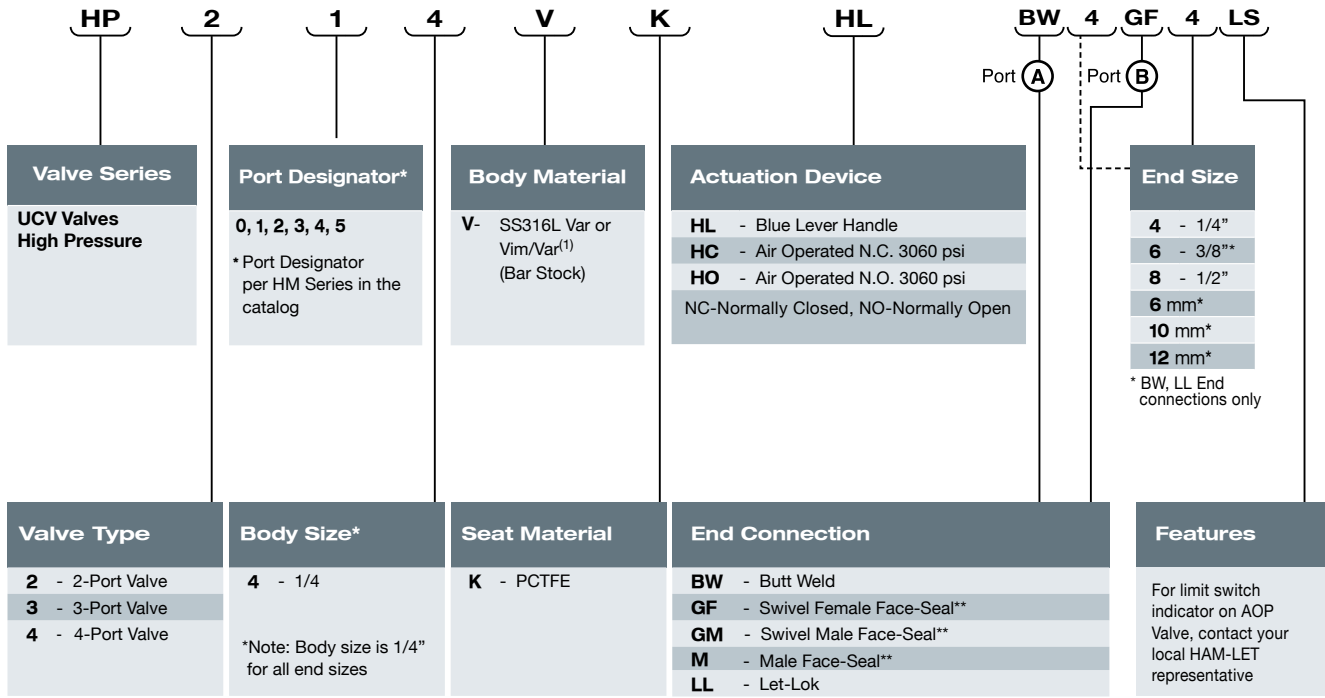

** 1/4", 1/2" End connection size only

PORT DESIGNATOR - (TOP VIEW)								
Valve Configuration	Port Designator	Schematic Flow Chart	Valve Configuration	Port Designator	Schematic Flow Chart	Valve Configuration	Port Designator	Schematic Flow Chart
2 Port Valve HP2 	0		3 Port Valve HP3 	0		4 Port Valve HP4 	0	
	1 L-Port			1			1	
	2 L-Port			2			2	
			3		3			
			4					
			5					

(1) Per SEMI F20-0305

UCV HM, Rev.06, January 2015

